

eS_{pro} 3

Professional electric vehicle
Owner's manual and warranty booklet



Askoll
I am electric

MADE IN ITALY

www.askollelectric.com



Welcome to the electric age!

With the purchase of the Askoll eSpro 3, you can finally enjoy a vehicle that combines the very best of Askoll's functionality, design and technology – a company with thirty years' experience in the design and manufacture of electric motors.

This manual has been prepared to help you fully appreciate its qualities. It contains information, warnings and advice regarding the correct use and maintenance of your new vehicle.

It is important to read it in its entirety before driving the vehicle for the first time. You will also discover details and features that will help convince you that you have made an excellent choice.

This publication is to be considered an integral part of the vehicle. In the event of the vehicle being sold, it must be handed over to the new owner.

Due to ongoing developments in design, which ensure the safety and quality standards of Askoll vehicles, some of the information contained in this Owner's and Maintenance Manual may differ from the vehicle in your possession. We are therefore confident that you will understand that the data, illustrations and descriptions provided here cannot form the basis for any claim.

INDEX	II
GENERAL INFORMATION	1-2
CONTROLS AND INSTRUMENTS	3-4-5-6-7-8-9
USE	10-11-12-13-14-15-16-17-18-19
BATTERY AND CHARGING	20-21-22-23-24-25-26
ADJUSTMENTS AND REGULAR MAINTENANCE	27-28-29-30-31-32
ERROR CODES	33-34-35-36-37-38
VEHICLE SPECIFICATIONS AND DIMENSIONS	39-40-41
GENERAL WARRANTY TERMS AND CONDITIONS (Scope of the standard warranty)	42
GENERAL WARRANTY TERMS AND CONDITIONS (exclusions)	43-44
GENERAL WARRANTY TERMS AND CONDITIONS (Customer's Obligations)	44
GENERAL WARRANTY TERMS AND CONDITIONS (Limitations of Liability)	45
GENERAL WARRANTY TERMS AND CONDITIONS (Nature of this warranty)	45
GENERAL WARRANTY TERMS AND CONDITIONS (Maintenance booklet, vehicle service records)	46-47-48-49

GENERAL INFORMATION

SYMBOLISM

The manual contains particularly important information that requires closer attention.

Each indicator is represented by a different symbol to highlight the content of the text that follows it and to help locate the topics within the various sections.



This symbol indicates particularly dangerous situations which, if not avoided, may result in death or serious injury.



This version of the warning sign will be used in the manual



This symbol indicates a general safety warning. It is used to warn you of a potential risk of injury to people and/or damage to property.



Failure to comply with these instructions, or compliance that is incomplete, may result in serious damage to the vehicle and, in some cases, may invalidate the warranty.



The guidelines set out the correct behaviour to adopt in order to avoid causing damage to the environment through the use of the vehicle.

IMPORTANT SAFETY INFORMATION



It is essential that you familiarise yourself with the electric vehicle: please read and understand this manual before using it for the first time



This owner's manual is an integral part of the electric vehicle; please keep it for future reference. If you sell the vehicle, it must be handed over to the next owner.



The scooter is not intended for use by persons whose physical, sensory or mental capabilities are impaired, or who lack experience or knowledge, unless they have received supervision or instruction regarding the use of the scooter from a person responsible for their safety

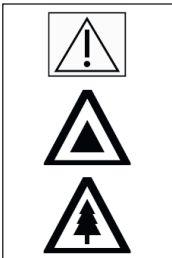

Failure to comply with these instructions, or compliance that is incomplete, may result in serious injury to persons, damage to the vehicle or the environment, and in some cases may invalidate the warranty



Any modification that alters the performance or basic structure of the scooter is not only prohibited by law but also renders the vehicle non-compliant with its type-approval and, therefore, a safety hazard

IDENTIFICATION

The identification numbers are stamped on the chassis and in the under-seat compartment; they must always be quoted when ordering spare parts.

It is advisable to check that the vehicle's identification numbers match those shown on its registration documents.

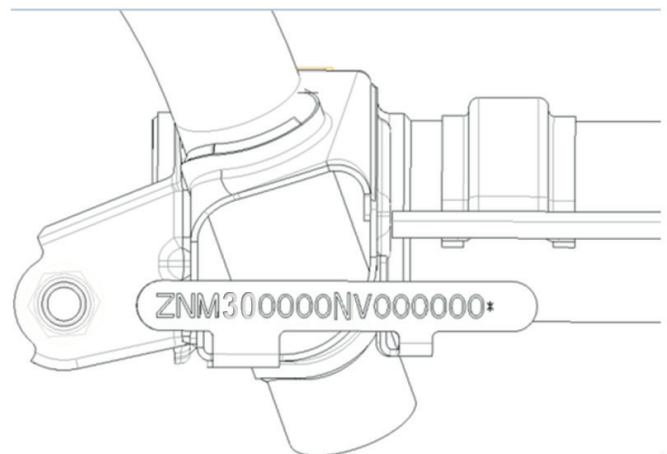
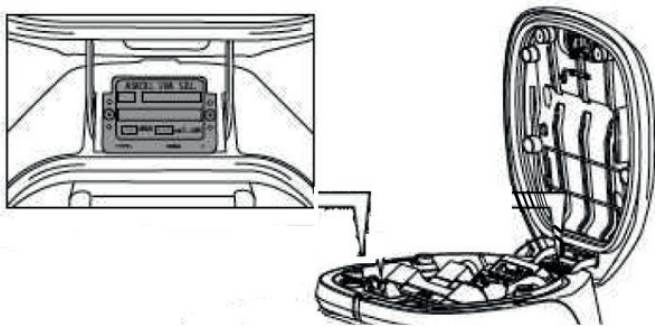

WARNING

Tampering with identification numbers may result in serious criminal penalties.

CONTROLS AND INSTRUMENTS

OVERVIEW OF THE VEHICLE

eSpro 3

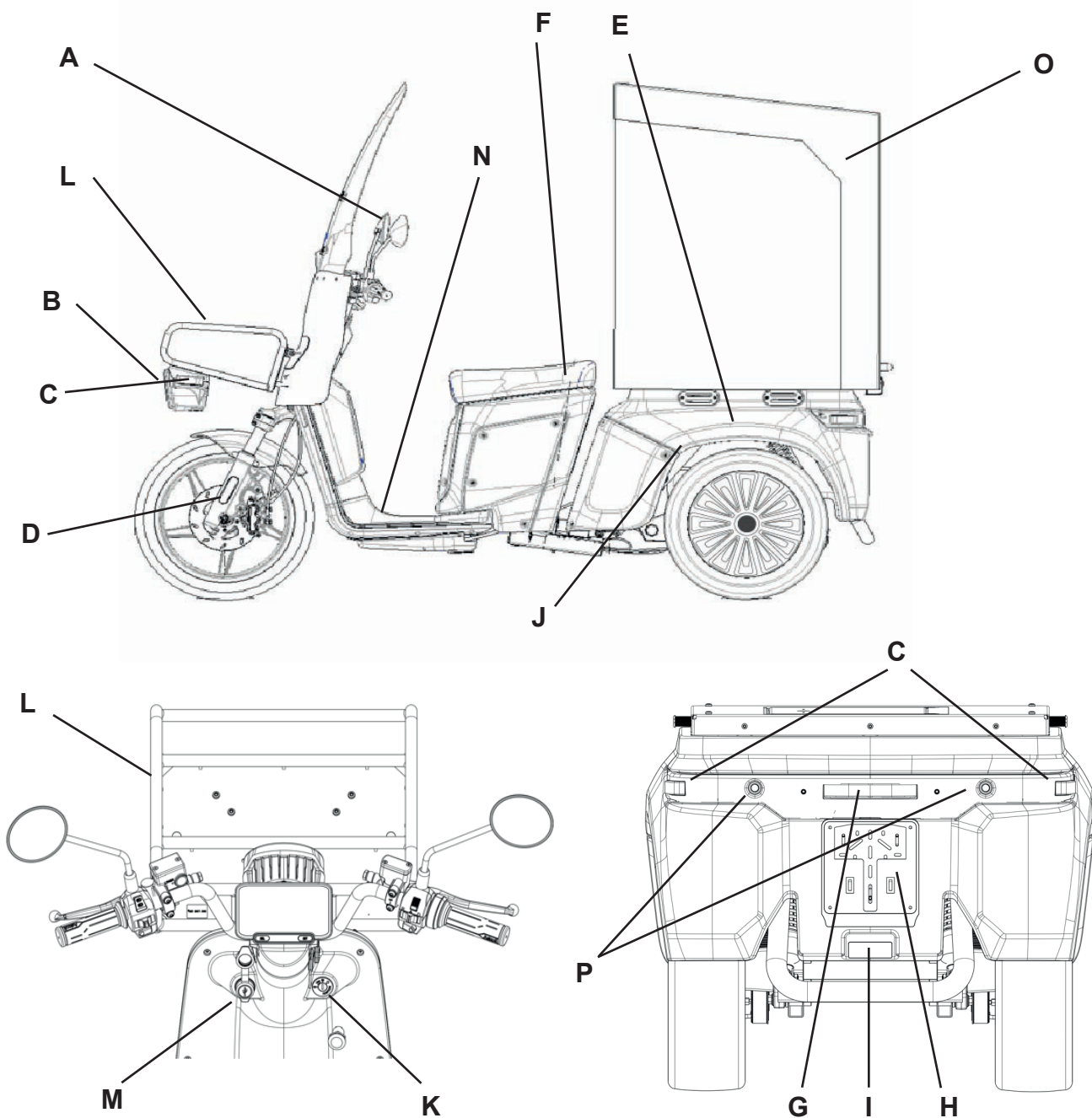

- A. Rear-view mirror
- B. Front headlight assembly
- C. Front and rear indicators
- D. Front reflectors on the right and left fork
- E. Battery compartment and load-bearing base
- F. Seat
- G. Rear light
- H. Number plate holder

- I. Rear reflector
- J. 2 motors positioned on the right and left sides
- K. Ignition switch
- L. Front basket
- M. USB Type-A/C socket
- N. Combined foot brake
- O. Rear boot
- P. Parking sensors

CONTROLS AND INSTRUMENTS

LAYOUT OF CONTROLS AND INSTRUMENTS

eSpro 3 Dashboard

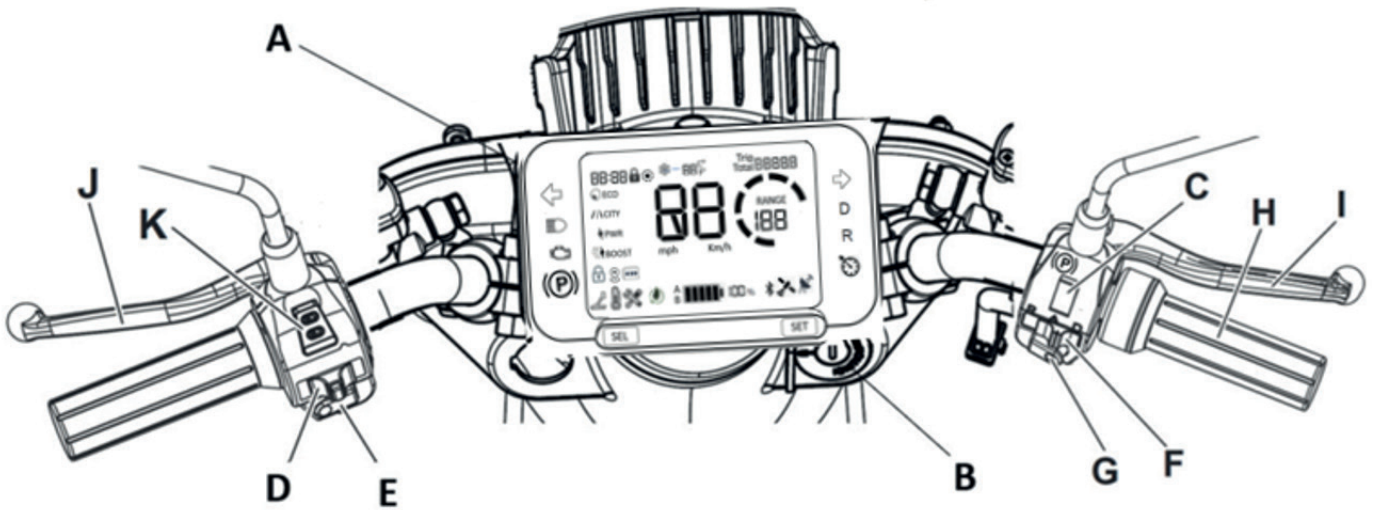

- A. Instrument panel
- B. Ignition switch
- C. Parking brake lever
- D. Indicator switch
- E. Horn button
- F. Drive mode selector

- G. Engine start button
- H. Throttle control
- I. Front brake lever
- J. CBS combined brake lever
- K. Headlight switch

CONTROLS AND INSTRUMENTS

LEFT-HAND CONTROL PANEL

CBS combined brake lever

Rear brake lever with combined function. It acts primarily on the rear wheels and the front wheel, ensuring greater safety and shorter stopping distances.

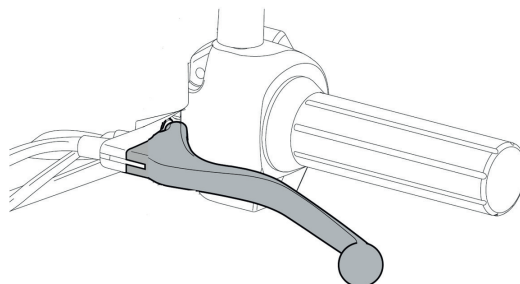

High beam switch

Utilizzando il selettore è possibile attivare la luce abbagliante.

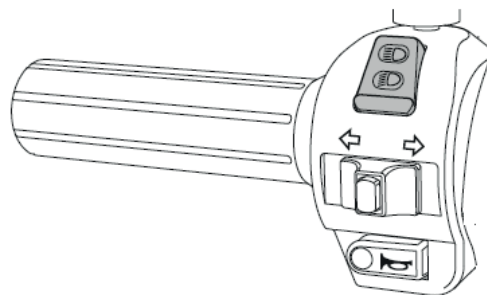

Indicator switch

Move the lever to the left to activate the left indicators.

Move the lever to the right to activate the right indicators.

Press the button in the centre of the lever to switch off the indicators.

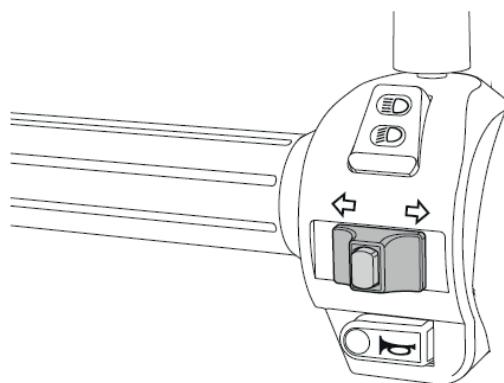

Horn button

Press to sound the horn.

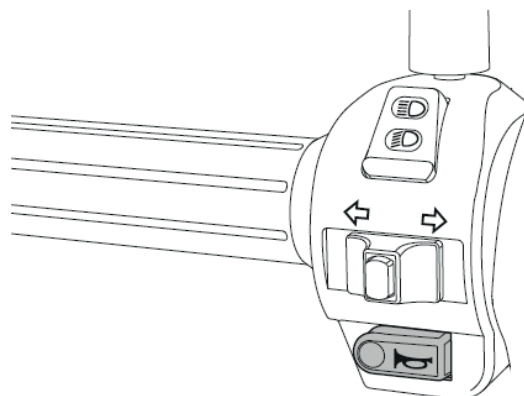

RIGHT-HAND CONTROL PANEL

Front brake lever

The front disc brake lever is located on the right-hand side of the handlebars and only brakes the front wheel

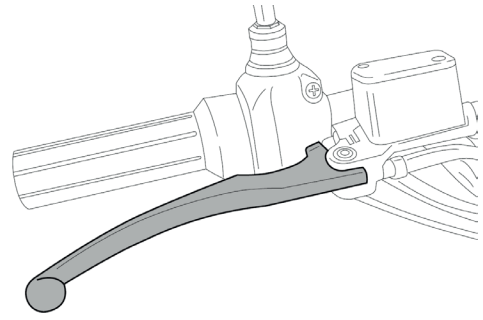

Throttle control

The speed of the scooter is adjusted by turning the knob.

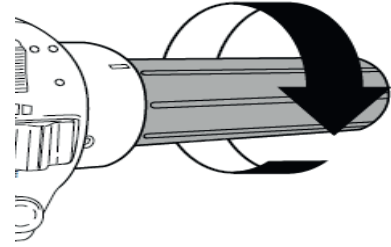

Electric parking brake control

The electric parking brake button on the **eSpro 3** is located on the left-hand side of the handlebar.

The parking brake button engages the electric system, locking both rear wheels and the tilt mechanism, thereby preventing the vehicle from tilting.

The locking system is disengaged by pressing the button again.

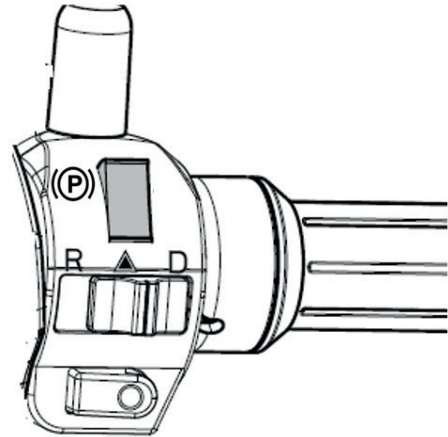

Please note: the parking control does not act as a brake whilst the vehicle is in use

Drive mode selector

Using the switch, you can select the driving modes

Position D = engage first gear

Position  = the hazard warning lights are switched on (1)

Position R = put the car in reverse

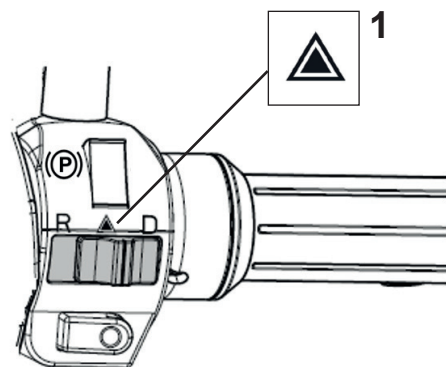

Reverse gear must be engaged when the vehicle is completely stationary, with both feet on the ground. The maximum speed in reverse is 3 km/h; whilst reversing, the four hazard warning lights and the intermittent audible buzzer are automatically activated. If reverse gear is engaged by mistake whilst driving forwards, the vehicle will not respond to the command; the incorrect command is indicated on the dashboard by the letter 'R' flashing intermittently on the speedometer display. The 'D' gear indicator remains active, and the audible buzzer sounds continuously.

CONTROLS AND INSTRUMENTS

Motor start button

Pressing the button for 3 seconds, depending on the position of the key in the ignition switch, enables or disables the motors.

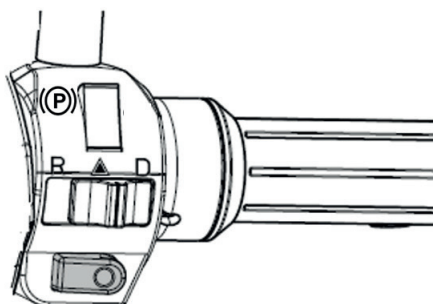

IGNITION KEY SWITCH

The ignition key switch activates or deactivates the motors and the steering lock. The scooter is supplied with a main key and a spare key, which can be used both to start the vehicle and to open the seat. We recommend keeping the spare key separate from the main key.

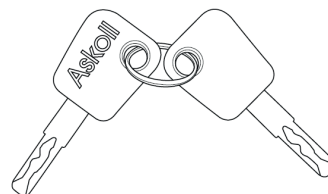

Enabling and disabling the system

By turning the key to  enable the system.

By turning the key to  disables the system.



WARNING

Do not turn or remove the key whilst the vehicle is in motion

SET OF KEYS SUPPLIED WITH THE VEHICLE

In addition to starting the engine, the keys supplied with the vehicle can be used to open the under-seat compartment (see section on page 18), the battery compartment and the rear luggage compartment (see sections on page 23)

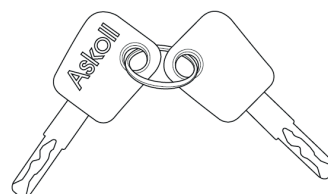

INSTRUMENTATION



- A. Indicator lights
- B. Speedometer
- C. Digital display
- D. Display controls

INDICATOR LIGHTS

- H. Indicating that the indicators are on
- L. Engine OBD diagnostic indicator
- K. Indicating that the full-beam headlights are on
- G. Parking brake and tilt lock indicator
- I. Forward gear indicator
- F. Charging in progress indicator
- N. Reverse gear indicator
- M. High temperature indicator

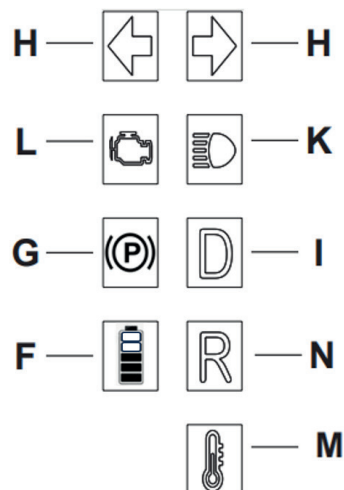

High temperature indicator

The high-temperature warning light is amber; it comes on and remains lit to indicate an overheating alarm. The corresponding alarm code is shown on the display. For a description of the alarm corresponding to the code displayed, please refer to the section “**ERROR CODES**”.

Electric parking brake indicator and tilt lock

The warning light for the electric parking brake and tilt lock system comes on both when the vehicle is started and when the dedicated button on the right-hand handlebar control is pressed. The system locks both rear wheels and the tilt mechanism, preventing the vehicle from tilting sideways.

The system is deactivated by pressing the button again: the indicator light goes out. If the indicator light on the dashboard flashes, this indicates a problem with the parking brake system.

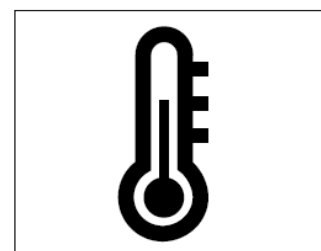

CONTROLS AND INSTRUMENTS

Indicator showing that the indicators are in use

The indicator light is green; it comes on and flashes to indicate that the right or left indicator has been activated, and goes out when the indicators are deactivated.

High beam indicator

The high-beam indicator light is blue; it comes on when you operate the switch on the left-hand stalk.

Charging indicator

The charging indicator light is amber; it comes on and remains lit when the charger is connected to the mains and the batteries are charging. It also comes on when energy recovery mode is activated.

OBD diagnostic system error indicators

The OBD (On-Board Diagnostics) system warning lights are amber in colour and come on during communication between the vehicle and the external diagnostic device.

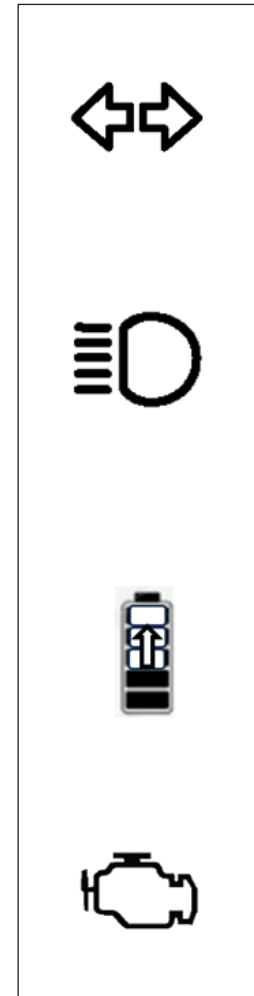

SPEEDOMETER

The speedometer shows your current speed. The reading is displayed in kilometres per hour (km/h).

MENU SETTING BUTTONS

The SEL and SET buttons should be used to:

- select the parameter to be shown on the display,
- reset the displayed value (km/trip),
- set and confirm new values (time).



DIGITAL DISPLAY

The digital display provides all the information on the vehicle's status, specifically:

- whether batteries are connected in the designated compartment,
- battery charge level,
- total distance travelled,
- partial distance travelled,
- distance that can be travelled with the remaining battery charge,
- time,
- alarms and associated error codes.



SELECT DISPLAY FUNCTIONS

Odometer data display modes

When the unit is switched on, all the indicator lights on the display will remain lit for a few seconds.

Press **SEL** to change the parameter shown on the display:

Total Total distance travelled.
This setting cannot be changed.

Trip Trip mileage.
Press and hold **SET** to reset whilst the parameter is displayed.

Vehicle range

The range displayed on the screen is an estimate of the vehicle's remaining range under standard conditions.

Range

Distance that can be travelled on the remaining battery charge. This figure varies depending on the battery's state of charge and the amount of charge remaining.

A batterie cariche il veicolo utilizza la modalità power. Quando le batterie si scaricano interviene la modalità ECO. In modalità ECO il veicolo detiene un'autonomia di circa 15 km, e la velocità si riduce a 30 km/h.

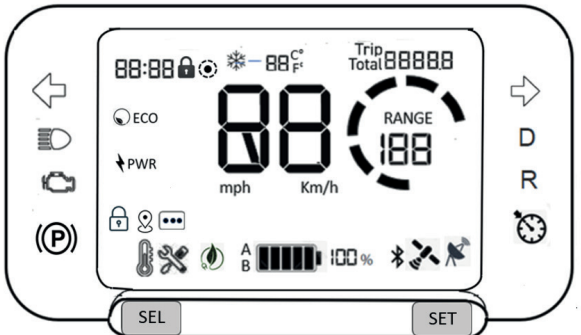
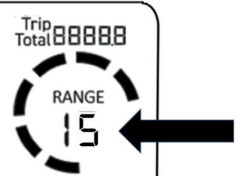

WARNING: If this happens, head to a charging point as soon as possible.

Setting the clock function and adjusting the date and mileage

- Press and hold the SEL button to enter edit mode.
Using SEL, you can only advance the data (e.g. 2024 -> 2025).
- After setting the desired year using SEL, press SET to move on to the next setting, i.e. the date.
- Press the SEL button to switch between day and month, and SET to move forward: here you can first change the month (always pressing SET to move forward), then the day of the month; press SET to move forward to the next setting, namely the time.
- Press SEL to advance through the hours and then the correct minutes.
- Press the SET button to move to the next setting, namely kilometres or miles ("km/h or mph");
- Press the SEL button to choose between km/h or mph, and set the correct option.
- Press the SET button to proceed to the next setting for temperature in Celsius or Fahrenheit (°C or °F), press the SEL button to choose between °C or °F.
- Press the SET button to exit edit mode

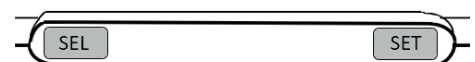

USE



CHECKS BEFORE DEPARTURE

Before using the vehicle, it is always a good idea to carry out a few checks:

- check the battery charge level,
- check that the headlight, tail light, indicators and number plate light are working,
- check that the front and rear brakes are working,
- check the fluid level in the front and rear brake reservoirs.
- check the tyre pressure,
- check that the seat is locked in the lowered position.

To carry out these checks correctly, refer to the instructions contained in this manual

SAFE DRIVING

WARNING	Before using the vehicle for the first time, we recommend that you test it in areas closed to traffic until you are fully familiar with it.
WARNING	Always drive within your limits.
	Driving whilst under the influence of alcohol, drugs or certain medicines is extremely dangerous and is prohibited by law.
WARNING	Always wear a helmet and fasten it securely before setting off.
WARNING	On uneven roads, in wet or snowy conditions, or on slippery roads, you must reduce your speed, increase the safety distance from other vehicles, and drive with caution.
	Do not brake hard on wet, unpaved or slippery road surfaces.
WARNING	After driving for a long distance on a wet road without applying the brakes, braking performance will initially be reduced. It is advisable to apply the brakes periodically in these conditions.
	In wet weather, visibility is reduced; please reduce your speed and drive carefully.

STEPS FOR STARTING THE VEHICLE

Engaging and disengaging the steering lock

To engage the steering lock, turn the handlebars to the left as far as they will go.

Press the key inwards and turn it anti-clockwise (1); At the same time, turn the handlebar slightly clockwise until the key clicks into place on the padlock symbol; The steering lock is now engaged and you can remove the key.

To unlock the steering lock, insert the key into the ignition switch (2) and turn it to the right at the unlock symbol the handlebar is free to turn again.

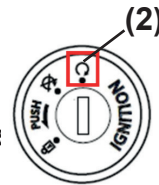
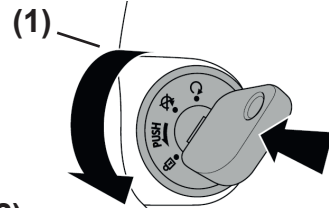
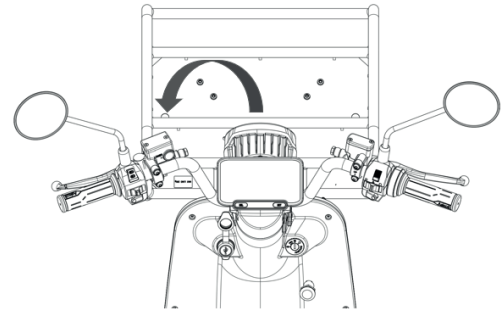

Motor enablement

The engine must be switched on before it can be : To switch on the engine, insert the key into the ignition switch and turn it to the position marked with the symbol (2) Then press and hold the **MODE** button (to activate the motor) for 3 seconds; the indicator light will come on (D) the start button on the dashboard.

When the ignition is switched on, the vehicle displays the parking brake engaged to disengage the parking brake, briefly press the button (P) on the right-hand side of the handlebars. Then select the driving mode by operating the switch provided on the right-hand control (4):

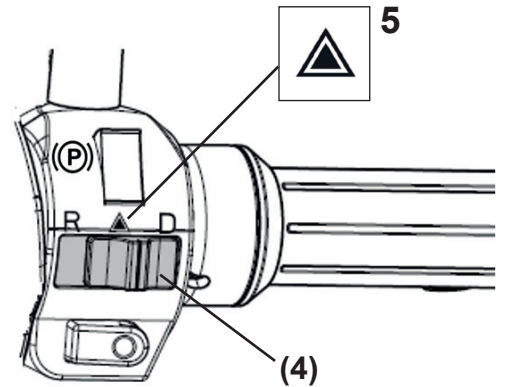
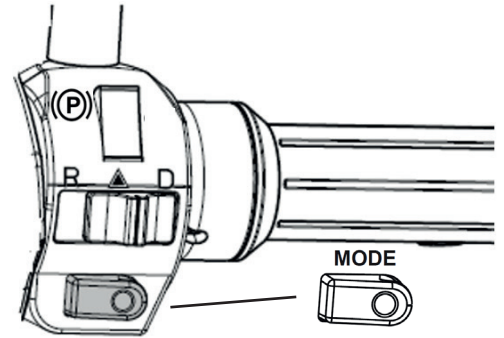
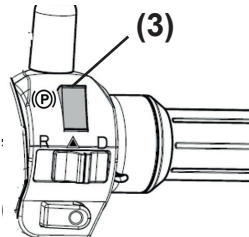

Position D = When first gear is engaged, the vehicle's maximum speed is limited to 65 km/h.

Position ▲ = the hazard warning lights are switched on (5)

Position R = When reverse gear is engaged, the maximum speed in this mode is 4 km/h

To switch off the engine, press the **MODE** button again for 1 second and turn the key in the ignition switch to the left to the symbol . The vehicle switches off. The engine can also be switched off simply by turning the ignition key to the position marked with the symbol without necessarily pressing the **MODE** button.

USE

AUTONOMY

Autonomy: the vehicle has a range of up to 120 km according to regulations **168/2013 UE (WLTP)**

WARNING

Over time, lithium-ion batteries experience a gradual decline in performance, which reduces their initial range.

WARNING

The range figures given depend on the battery charge level, the number of recharge cycles, and the operating temperature. Operating conditions can also affect the range: gradient and/or type of surface, ambient temperature, average speed, tyre pressure, load weight and rider weight, and battery age.

USB socket

The vehicle is fitted with a USB and USB-C socket located at the top left of the vehicle's interior dashboard, opposite the ignition switch. The USB socket has an output voltage of 5V, 2A: it is possible to charge smartphones and external devices.

WARNING

When the USB socket is not in use, we recommend keeping the socket cover closed, especially in wet weather, to prevent water ingress.

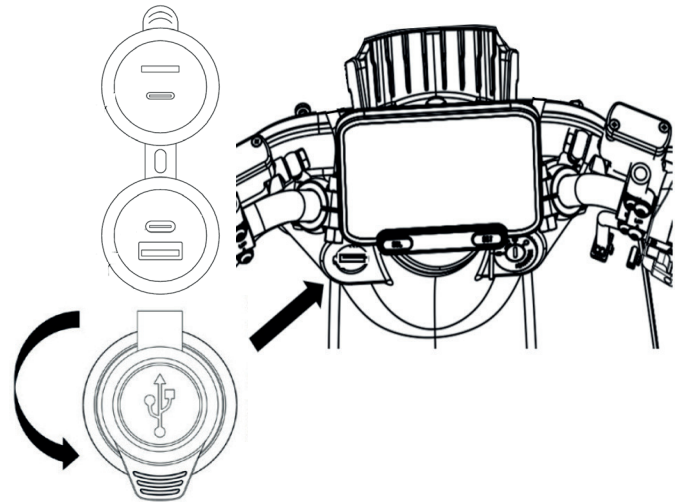

OBD DIAGNOSTICS

The eSpro 3 vehicle is equipped with the OBD (On-Board Diagnostics) fault detection system, in accordance with the provisions of the EURO 5 Environmental Regulation, which came into force for all new vehicles manufactured from 1 January 2021. In accordance with the requirements of ISO 19689:2016, relating to communication between the vehicle and external diagnostic equipment, the OBD connection for electronic fault detection is located in the compartment under the seat.

Position of OBD connector

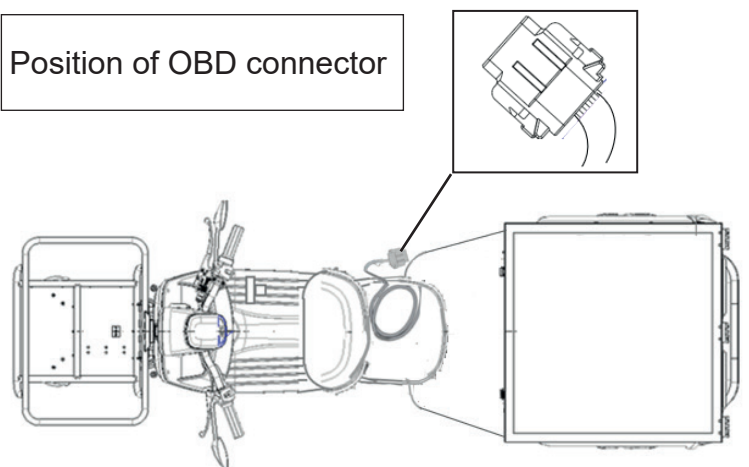

SADDLE

Seat opening

Turning the key to the left opens the vehicle seat. When the seat is closed again, the lock will engage automatically.

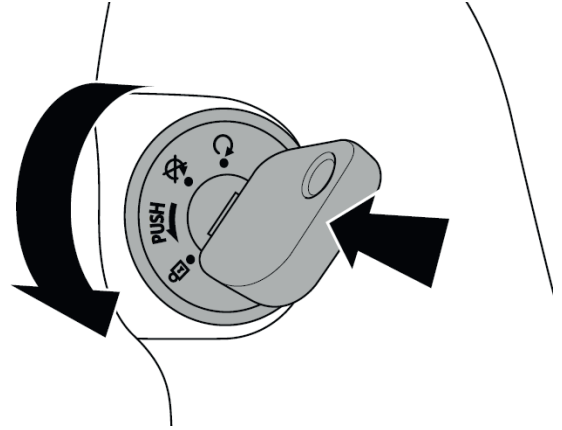

The compartment under the seat contains the OBD diagnostic cable (1) and the cable with a Scame plug for on-board battery charging (2)

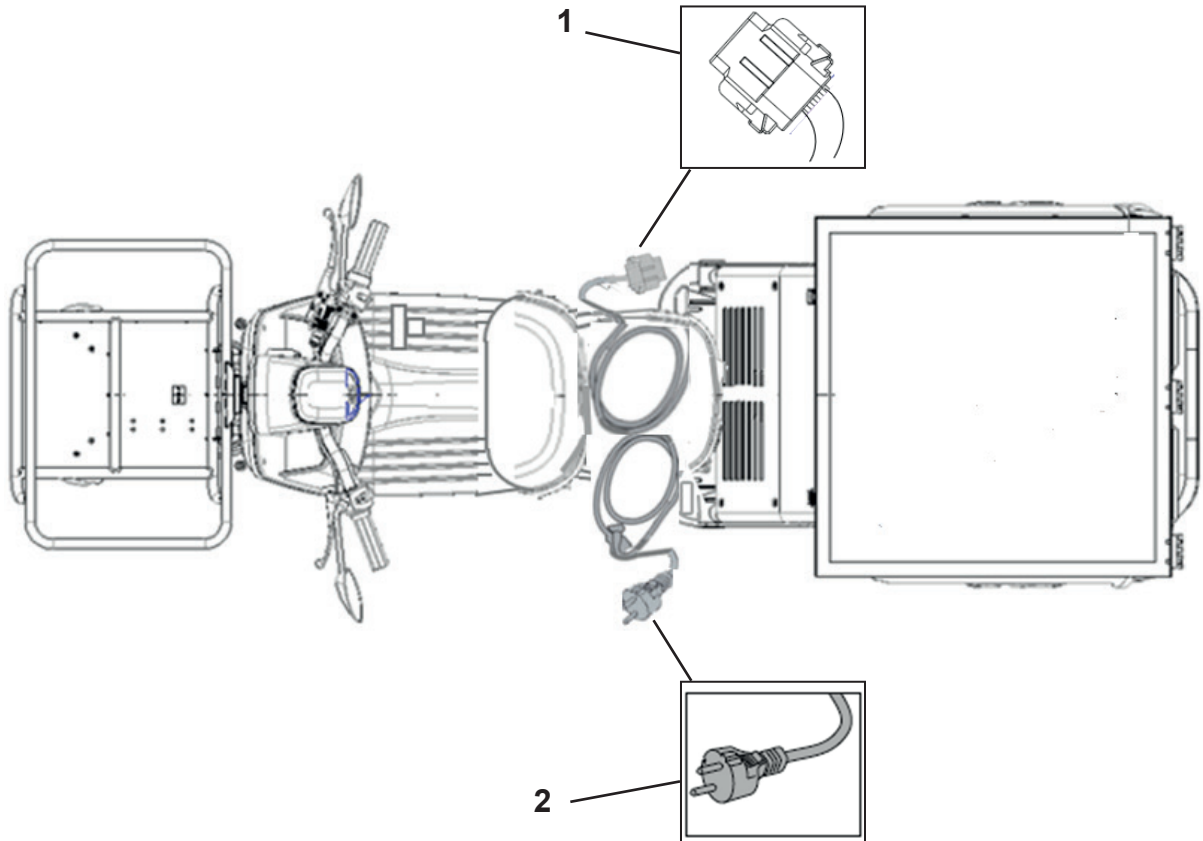

USE

CONNECTIVITY

The eSpro 3 vehicle is equipped with a connectivity system, which enables remote monitoring of the vehicle.



Connectivity

The connection status is indicated by the relevant symbol on the digital display **(1)**:

- Icon lit: the module is connected to a device.
- Icon off: no devices are connected.

SYSTEM CONNECTION AND MTR2023 BADGE READER POSITION

MTR2023 Badge Reader

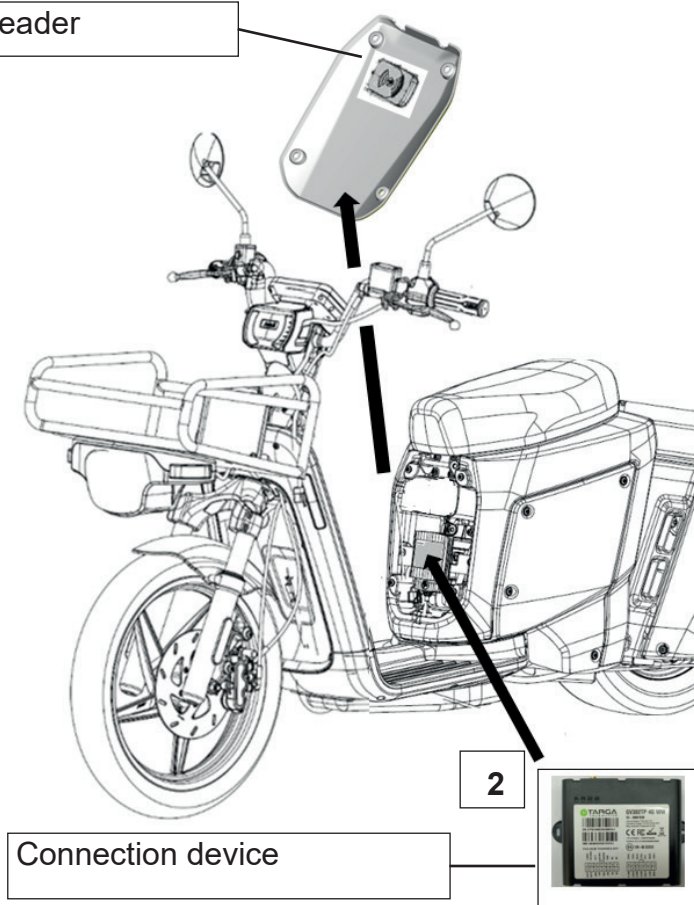

Connection device

Position of the connection device and the MTR2023 badge reader

The connection system is located behind the front panel under the seat and is secured to the vehicle's internal frame **(2)**.

The MTR2023 badge reader is mounted directly on the inside of the front panel under the seat. The devices can be accessed directly by unscrewing the four screws securing the panel under the seat and removing the panel.

INSTRUCTIONS FOR USING THE OPERATOR IDENTIFICATION BADGE

The vehicle is fitted with a badge reader for operator identification; the area where the badge should be placed is indicated by a sign on the fairing beneath the seat (1).

To use the Badge, you must first start the vehicle by turning the ignition key to the ON position near the relevant symbol . The operator can then place their badge on the designated area (1).

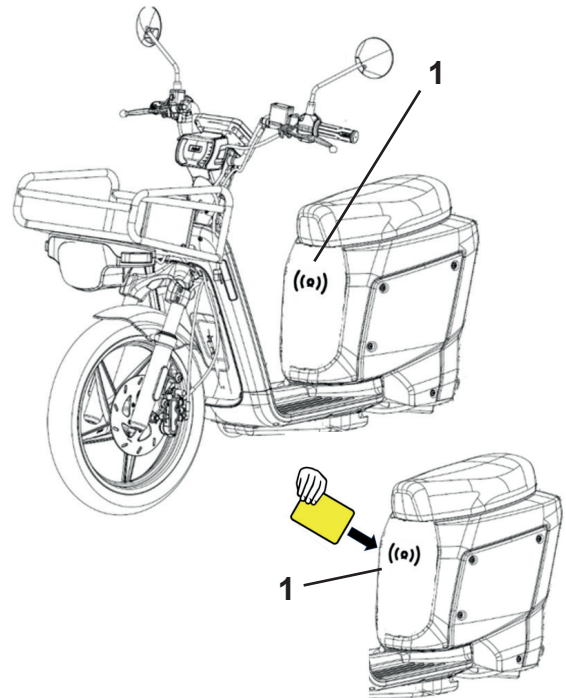

User guide for the MTR2023 badge reader

To access information on the functions relating to the vehicle's MTR2023 badge reader, please refer to the link below.

Manufacturer's Declaration TARGA TELEMATICS SPA., Via E. Reginato, 31100 Treviso (TV) Italy, declares that the MTR2023 radio equipment complies with Directive 2014/53/EU.

The full text of the EU Declaration of Conformity is available at the following web address:

<https://www.targatelematics.com/tecnologie-ai-e-big-data-per-smart-mobility/hardware-e-black-box/>

MTR2023 BADGE READER (Multi Technologic Reader 2023)

Technical specifications, transmission frequencies and corresponding power levels

The device has the following technical specifications:

RF output power

- 125 mW VCC= DVCC = 3,3V
- 345 mW VCC = 5V, DVCC = 3,3V

USE

Information on usage and connectivity

For information on the vehicle's connectivity features, please refer to the device supplier's technical documentation at the following link:

<https://manuals.plus/m/f5900e1af5882f05a3c944d40c23182b2922e2cbd0e50281d5bc5a6853266281.pdf>

The supplier of the device, TARGA TELEMATICS SPA, Via E. Reginato, 31100 Treviso (TV), Italy, hereby declares that the GV302TP WW - IP67 radio equipment complies with Directive 2014/53/EU. The full text of the EU Declaration of Conformity is available at the following web address:

[GV302TP-4G-WW_Declaration-CE-RoHS.pdf](#)

CONNECTIVITY

Technical specifications of the GV302TP WW radio unit – IP67

The device has the following technical specifications:

GLONASS Receiver

- Range frequenza operativa: 1559 -1610 MHz

GPS Receiver

- Operating frequency range: 1559 -1610 MHz

GSM 900

- Operating frequency range: 880-915 925-960 MHz

- Maximum output power: assessed 33 dBm

GSM 1800

- Operating frequency range: 1710-1785, 1805-1880 MHz

- Maximum output power: assessed 30 dBm

LTE FDD Banda 1

- Operating frequency range: 1920-1980, 2110-217 MHz

- Maximum output power: assessed 23 dBm

LTE FDD Banda 3

- Operating frequency range: 1710-1785, 1805-1880 MHz

- Maximum output power: assessed 23 dBm

LTE FDD Banda 8

- Operating frequency range: 880-915, 925-960 MHz

- Maximum output power: assessed 23 dBm

LTE FDD Banda 20

- Operating frequency range: 832-862, 791-821 MHz

- Maximum output power: assessed 23 dBm

LTE FDD Banda 28

- Operating frequency range: 703-748, 758-803 MHz

- Maximum output power: assessed 23 dBm

VEHICLE PARKING

The vehicle is equipped with an exclusively electric parking brake.

The activation button for the parking system on the **eSpro 3** vehicle is located on the right-hand handlebar control, marked with the letter "P". The parking control button engages by locking both rear wheels and the tilt mechanism, preventing the vehicle from tilting. The locking system is disengaged by pressing the "P" button again.

The parking brake engages automatically every time the vehicle is switched off.

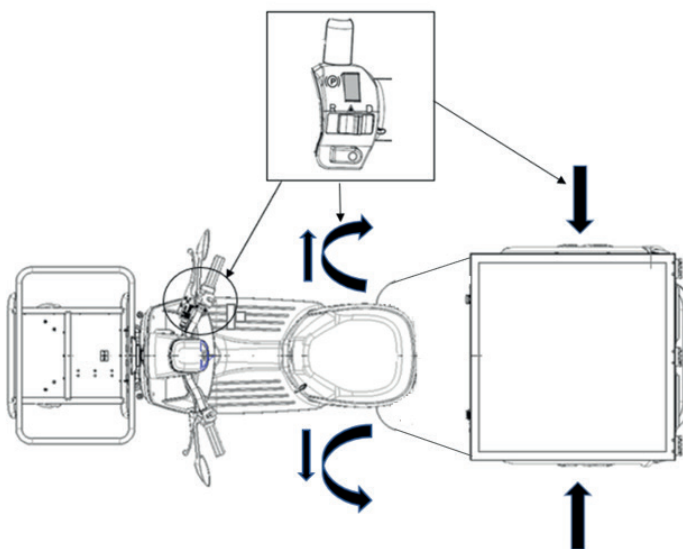

SYSTEM FOR BYPASSING THE PARKING BRAKE

It is possible to move the vehicle manually by bypassing the parking brake.

Start the vehicle by turning the ignition key to the ON position.

The icon will light up on the dashboard. (P) which indicates that the parking brake is engaged.

Then press the parking brake release button (P) on the right-hand control for 3–4 seconds, and at the same time turn the ignition key to the OFF position, the parking brake is released, and the vehicle can be moved manually.

If the vehicle is then restarted, the parking brake is activated automatically.

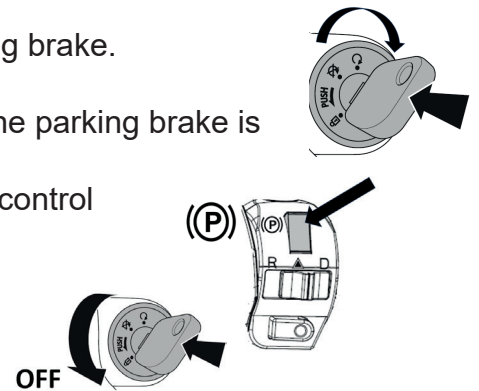

ATTENTION If the batteries run out whilst the vehicle is moving and the engine cuts out, the parking brake system does **NOT** remain engaged, so the vehicle can be moved even when stationary.



If the vehicle comes to a standstill due to the batteries running flat, the parking brake will no longer be operable; the vehicle must be parked safely, taking care to ensure that it cannot move inadvertently. To this end, and should this occur, wheel chocks must be placed at the base of the wheels to prevent them from moving.



If the batteries become completely discharged following a prolonged period of inactivity, the parking brake remains engaged and can only be released once the batteries have been recharged.

PARKING SENSORS

The vehicle is fitted with rear parking sensors (**Fig. 1**). The parking sensors are activated when the vehicle is switched on and reverse gear is engaged; obstacles are detected from a distance of 1 metre and indicated by an audible signal consisting of a beep that becomes faster and more frequent as the obstacle approaches.

The sensors deactivate when reverse gear is disengaged.

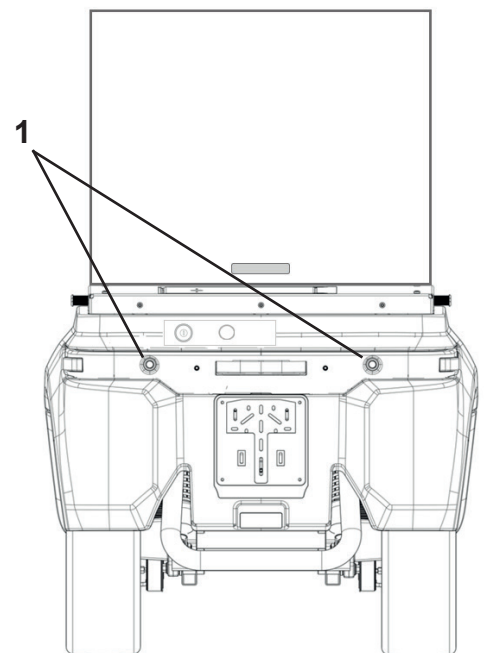

OPENING AND USING THE BOOT

The boot is opened using the button located on the lower left-hand side of the vehicle (1): the key should only be used in an emergency; the lock (2) is situated next to the boot release button.

If the boot is not closed properly, the “boot open” warning light (8) will come on in the dashboard.

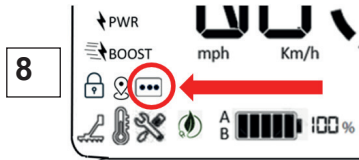
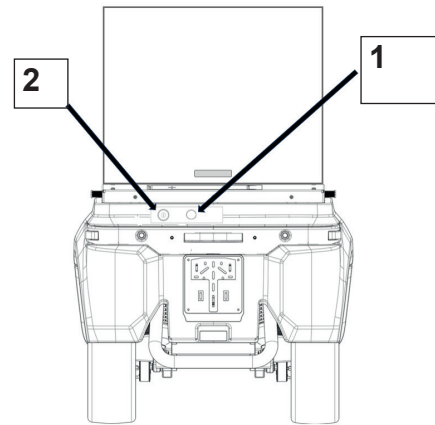

To open the boot, grasp the external handle located at the bottom of the boot (fig.3) and lift the lid (fig.4)

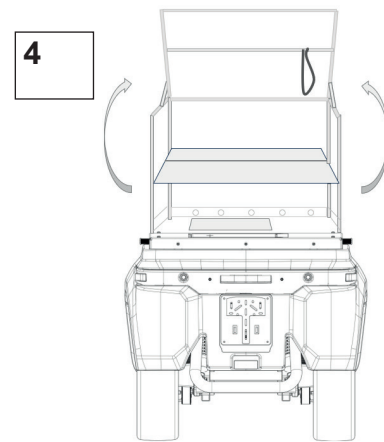
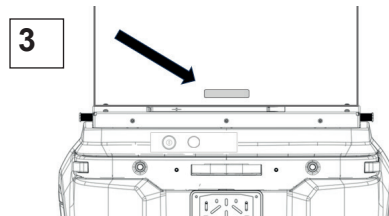

The boot has several adjustable shelves to suit your storage needs:

(fig.5) configuration with two full shelves,

(fig.6) configuration with the top shelf partially raised,

(fig.7) configuration with the top shelf fully raised, to maximise the boot's storage capacity.

(fig.8) To close the boot, use the interior handle

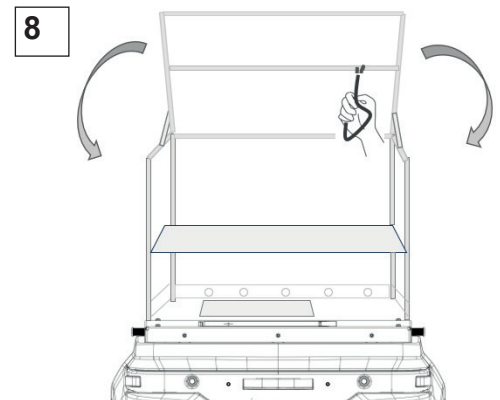
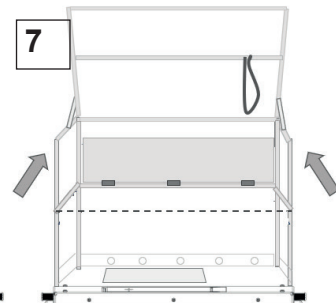
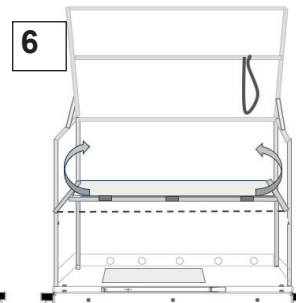
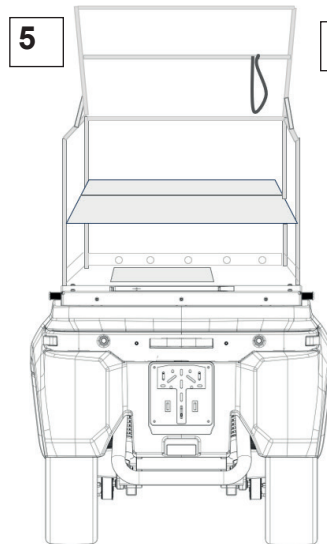

BATTERIES

The eSpro 3 vehicle is equipped with four removable high-capacity lithium-ion batteries (model TC116) (1.7 kWh x 4), each weighing 8 kg.

The four batteries are housed in the compartment located beneath the rear boot, which is accessed via the dedicated flap (**fig.1**). The batteries must be recharged at an ambient temperature between 0°C and +45°C: at low temperatures, a reduction in range may occur.

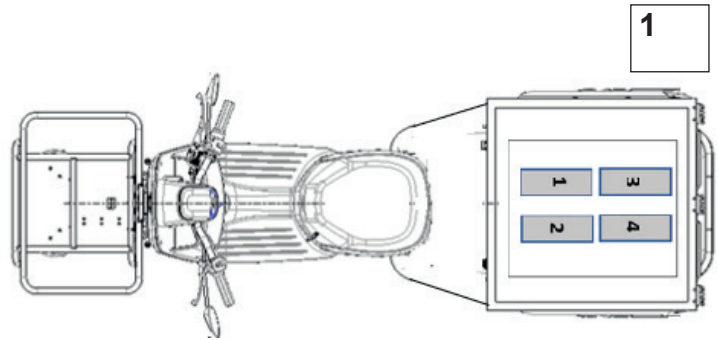

WARNING

If the batteries run completely flat whilst the vehicle is in use, the system still allows the battery compartment to be opened so that they can be replaced. The vehicle can operate with a minimum of two batteries (one per motor), which allows it to be restarted and the parking brake to be released.

WARNING

The batteries charge and discharge in parallel at a uniform rate; should there be a discrepancy in charge levels between the batteries, the system operates using those with the higher charge level, meaning that the less charged batteries are not used until the charge level of the batteries in use drops to match theirs. This situation results in a temporary drop in the vehicle's performance (speed, acceleration).

WARNING

Make sure you always use batteries with the same charge level.

RECHARGE PERCENTAGE



Batteries must never be left with a charge level of less than 20% for more than one week. If the vehicle is not in use, we recommend that you never allow the batteries to run completely flat, but always charge them to 100% and disconnect them from the vehicle's wiring.



When the vehicle is not in use, if the batteries are left inside, the battery charger must remain connected to the mains: the charger acts as a 'trickle charger' for the batteries, keeping the charge level constant.

Check the battery charge level at least once a month.

If fully charged batteries are stored outside the vehicle, check that they are retaining their charge at least every two months.



Failure to comply with the above instructions will invalidate the battery warranty.

BATTERY AND CHARGING



If the vehicle is left with the engine switched off for a long period in cold conditions (between 0 °C and +10 °C), the on-board battery charging time may be longer.



If the vehicle is not going to be used for a prolonged period, the batteries must be fully charged and disconnected from the vehicle's electrical system. Check the battery charge level at least once every two months.



The batteries must not be used at ambient temperatures outside the range of -10 °C to +45 °C.



The batteries must not be subjected to impact and must not show any signs of external damage of any kind.



Batteries, whether being charged or stored, must not be exposed to sources of heat or cold, damp, dust or the elements.



The warranty covers battery malfunctions resulting from manufacturing defects, as well as failure to charge or discharge.



The warranty does not cover any deterioration in battery performance resulting from normal use and ageing.



The manufacturer reserves the right to assess the validity of the warranty based on an analysis of the batteries.



Never disconnect the electrical cables whilst the engine is running, to avoid damaging the battery.



Dismantling and/or tampering with the batteries will invalidate the warranty.



In the interests of environmental protection, batteries must be decommissioned, collected and disposed of in accordance with current legislation at the end of their useful life.



Do not use this battery for any purpose other than that specified. Using it for any other purpose may cause a short circuit inside the battery, which could result in a fire.



It is not advisable to let the batteries run completely flat, as this may cause them to wear out prematurely.



Fire hazard

- Do not dismantle or damage the battery
- In the event of an accident causing serious mechanical damage to the battery, short circuits may occur inside the battery and it may be damaged or catch fire.
- If a fire breaks out and there is a risk of it spreading to nearby objects, contact the fire brigade immediately.



Failure to follow the recommendations set out above will result in the battery warranty being voided.

Disposal of used batteries

At the end of its useful life, a battery pack containing lithium batteries must be disposed of in accordance with current regulations and must not be treated as ordinary waste.

The European Directive on this type of waste stipulates that Member States must undertake to adopt 'appropriate measures' to ensure that spent batteries are collected separately, for the purposes of their possible recovery or disposal.

In any case, for the most up-to-date information on this matter, users are advised to contact the relevant local authority.



BATTERY AND CHARGING

TLPower 1200BG6020L Battery Charger

This charger is intended for use exclusively with the Askoll eSpro 3 vehicle.

The charger is only activated when connected to the mains using the dedicated power cable located under the vehicle's seat.

OPERATION OF THE BATTERY CHARGER

When the power cable is connected to the mains, the top fan of the battery charger starts up to keep the internal temperature low during charging.

The fan switches off when the power cable is disconnected from the mains.

The charger in the vehicle is located beneath the battery compartment: in this configuration, the hot air is expelled through vents situated near the number plate holder.



Risk of electric shock

- This appliance is fitted with a 3-pin cable with a plug featuring an earth contact. Ensure that the mains socket is also a 3-pin socket with an earth contact. If not, consult an electrician to have the socket replaced.
- Connect the appliance to a mains supply protected by a residual current device (RCD) with a sensitivity not exceeding 30 mA.
- The electrical connection of the appliance must comply with the specifications on its electrical data label.
- Do not use extension cables. If the power cable is too short, consult a qualified electrician or installer.
- Do not cut or repair the power cable

CHARGING THE BATTERIES

The battery charge level is shown in the centre of the vehicle's digital display. On the display, the A icon indicates the charge level of the four batteries housed in the compartment beneath the rear body.

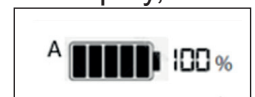

The batteries can be charged in two ways:

- **CHARGING WITH AN ON-BOARD BATTERY**
- **CHARGING WITH AN OFF-BOARD BATTERY**

CHARGE USING THE ON-BOARD BATTERY

To recharge the on-board battery, follow the instructions below:

Deactivate the vehicle system by turning the ignition key to the OFF position.



Open the boot using the button located on the lower left-hand side of the vehicle (fig.1)

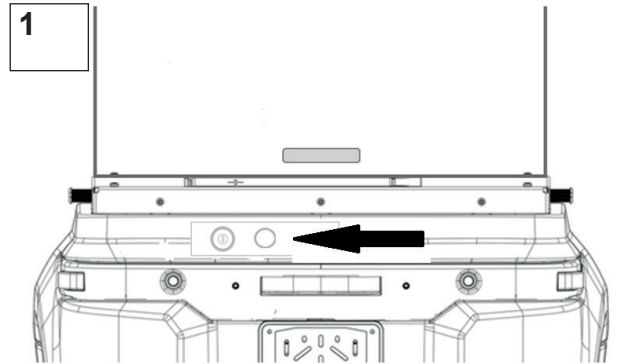

Lift the boot lid (fig.2) and open the flap on the battery compartment floor (fig.3) using the key provided (this is the same key used to start the vehicle)

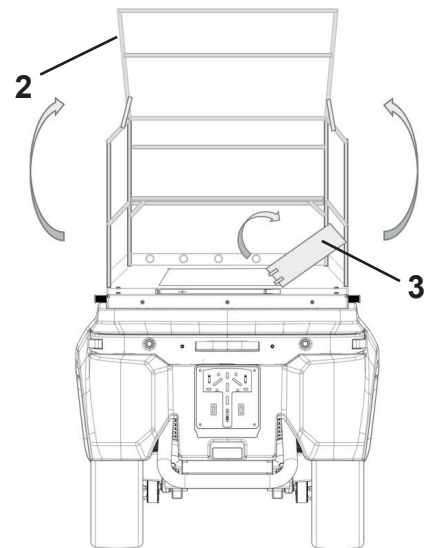

Check that the batteries are correctly inserted into the compartments, following the direction of the arrows (fig.4) on the top of the batteries (the arrow points towards the side where the batteries are inserted into the wiring connector).

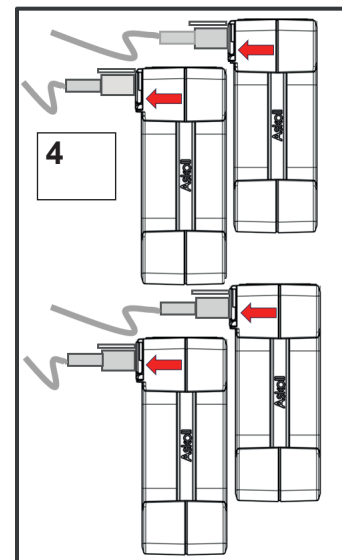

To charge the batteries, connect the cable (fig.5) located under the seat compartment to the mains supply.

During charging, the indicator light on the dashboard lights up

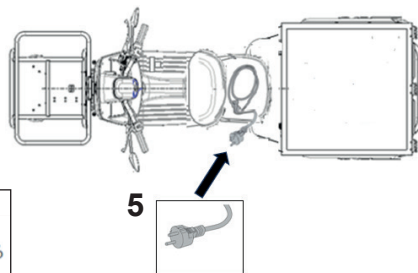
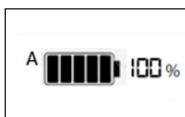

BATTERY AND CHARGING



To charge the ON-BOARD batteries, check that all the batteries are connected to their respective connectors, then connect the charging socket located under the seat to the mains supply.

ATTENTION

Charging times (under standard conditions at ambient temperatures of +10°C to +30°C) when using the on-board charger with fully discharged batteries can take up to 8 hours.

ATTENTION

The operating temperature of the batteries (whilst the vehicle is in use) can reach up to approximately 60°C. If you attempt to charge the vehicle immediately after use, the system may put the charging process on hold by switching the charging process to standby and illuminating the high-temperature warning light (fig.1) on the dashboard; charging will resume once the battery temperature drops below the safety limit of 45°C.

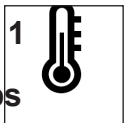

ATTENTION

If one or more batteries encounter an error during charging, the system continues to charge the remaining batteries; the batteries that have encountered an error remain on standby, and charging of these will resume once the remaining batteries have reached 100% charge; this may extend the charging time.

ATTENTION

If on-board charging takes place at low ambient temperatures (e.g. between 0°C and 10°C) or high ambient temperatures (above 35°C up to 45°C), charging times may be longer.
If ambient temperatures are below 0°C or above 45°C, the batteries will not charge.

CHARGE USING AN EXTERNAL CHARGER

It is possible to recharge the batteries outside the vehicle. This can be done using a dedicated 24-slot charging bay.

Disconnect the batteries from the connectors (**fig.1**), then remove them from the compartment under the boot, using the handle provided (**fig.2**) to lift them. Once the battery has been removed, hold it with both hands.

Place the batteries into the slots in the charging cabinet.

Connect the batteries to the charging cables inside the cabinet slots and switch on the power switch on the cabinet (**For this procedure, please refer to the IP54 battery charging cabinet manual**)

Once charging is complete, replace the batteries in their compartment by holding them by the handle, and reconnect the connectors to the batteries (**see instructions on page 23 regarding the positioning of the batteries inside the compartment**), ensure that the connector is inserted fully into the battery socket (**fig.3**), and check that it is securely locked into the flap on the battery, which also acts as a safety lock for the connector (**fig.4**).

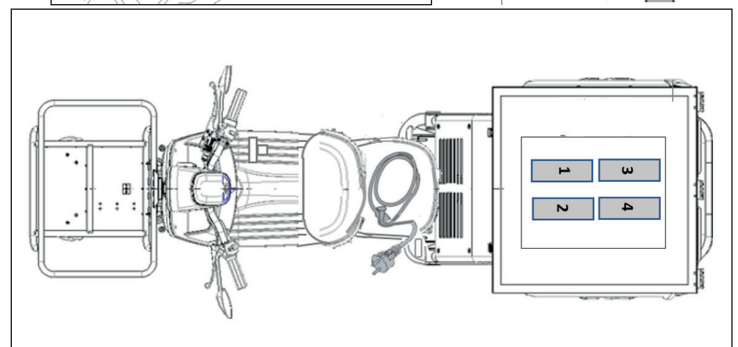
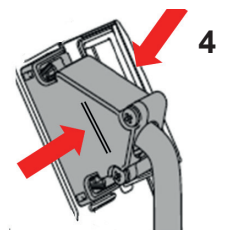
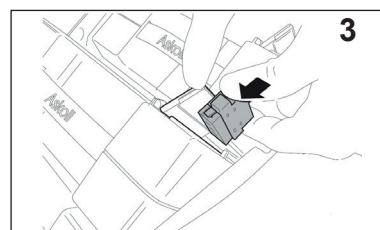
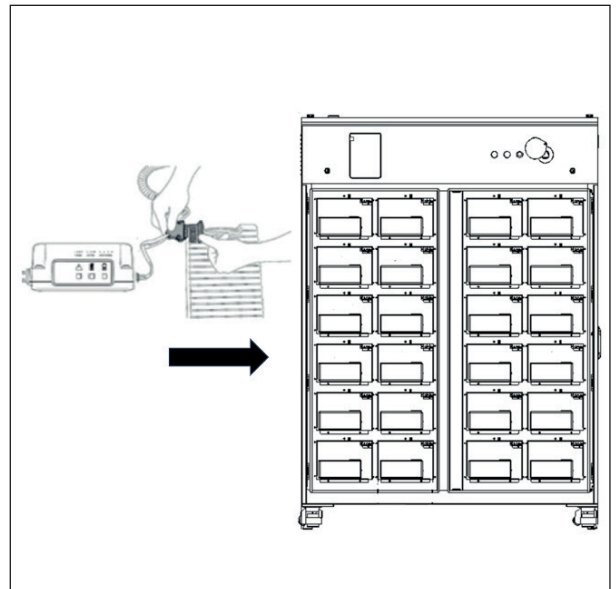
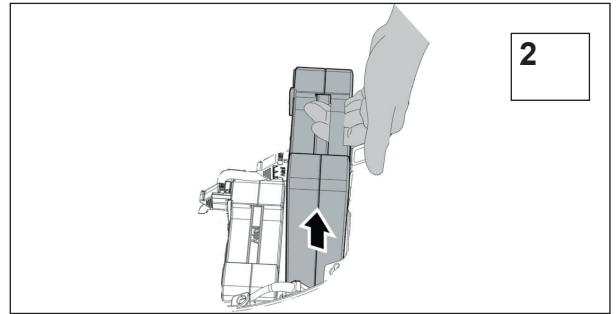
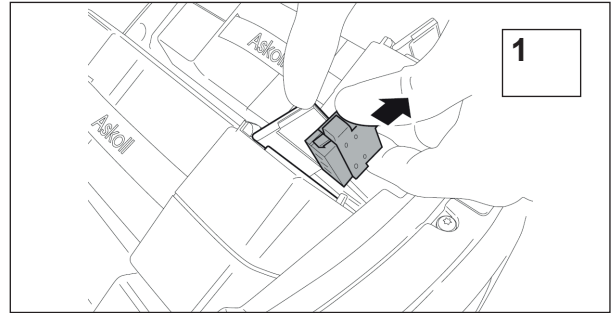

ADJUSTMENTS AND REGULAR MAINTENANCE

ADJUSTMENTS

REAR-VIEW MIRRORS

Mounted on the right and left sides of the handlebars are the two rear-view mirrors, which can be adjusted by manually rotating the stem until the mirror is in the desired position.

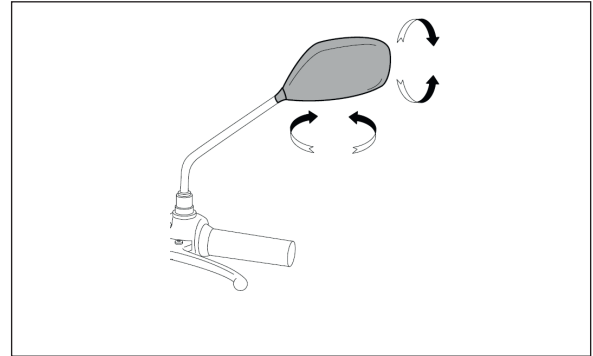

HEADLIGHT

You can adjust the height of the headlight beam by turning the adjustment screw located beneath the headlight using a TORX T 20 key. Turning the screw half a turn clockwise will direct the beam downwards; turning it anticlockwise will direct the beam upwards.

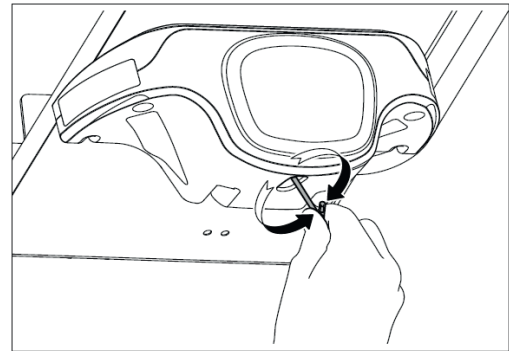

FRONT DISC BRAKE

Wear on the disc and pads is automatically compensated for, so it has no effect on brake performance and does not require adjustment. If excessive travel is detected and the lever comes too close to the grip when the brake is applied, this may indicate the presence of air in the system or irregular brake operation. Effective braking should begin after approximately 1/3 of the brake lever's travel.

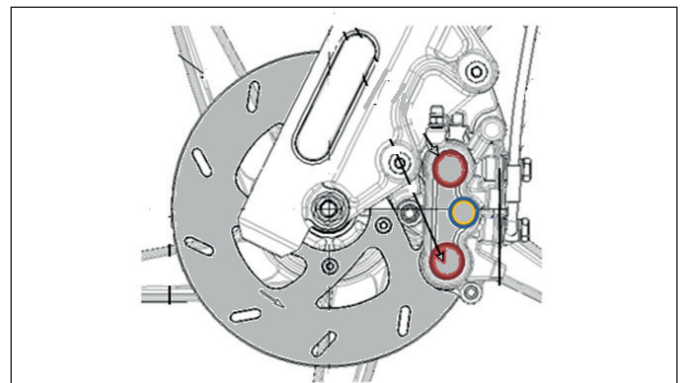

REAR DISC BRAKE

Wear on the disc and pads is automatically compensated for, so it has no effect on brake performance and does not require adjustment. If excessive travel is detected and the lever comes too close to the grip when the brake is applied, this may indicate the presence of air in the system or irregular brake operation. Effective braking should begin after approximately 1/3 of the brake lever's travel.

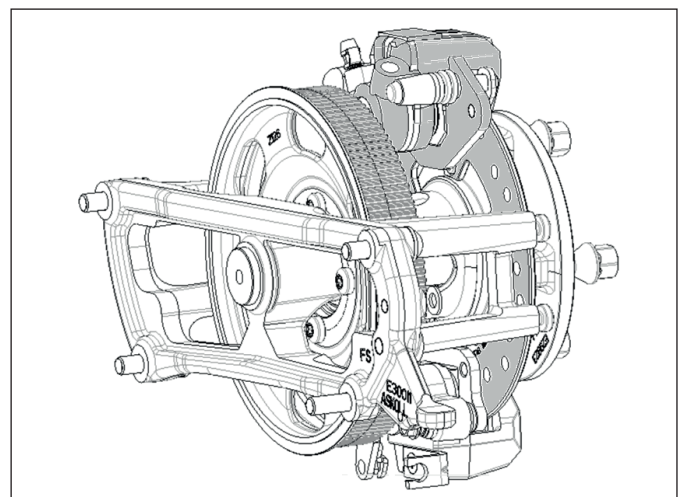

ADJUSTMENTS AND REGULAR MAINTENANCE

REAR BRAKE WITH COMBINED FUNCTION

Combined braking can be performed in two ways: either using the left-hand brake lever on the handlebars, or by pressing the pedal on the right-hand side of the footrest; the braking system acts on the rear wheel calipers and the front brake caliper

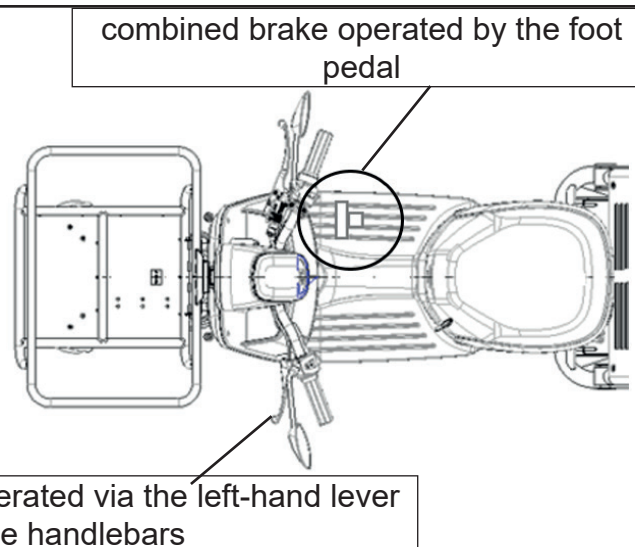

WARNING

If the brakes are not working properly, check the wear on the brake pads: if the brake pads are very thin, they must be replaced; this should be done at an authorised service centre

WARNING

After replacing the brake pads, press the brake pedal several times to ensure that the pads are correctly seated.

ROUTINE MAINTENANCE PROCEDURES

TYRES

The vehicle is fitted with tubeless tyres. Check the tyre pressure regularly and adjust it if necessary before setting off.

Front tyre pressure: 2 bar.

Rear tyre pressure: 2 bar.

The tyres are fitted with wear indicators and must be replaced as soon as these indicators are visible on the tread.

Also check for any cuts on the sides of the tyres or uneven wear. In such cases, contact an authorised workshop for replacement.

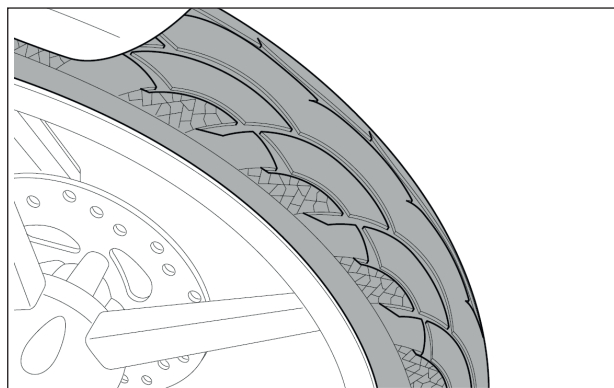

WARNING

Always check your tyre pressure when the tyres are cold; incorrect pressure causes abnormal tyre wear and makes driving dangerous.

WARNING

The tyre must be replaced when the tread depth reaches the wear limit specified by current regulations.

ADJUSTMENTS AND REGULAR MAINTENANCE

CHECKING THE BRAKE FLUID LEVEL

The front and rear brake fluid reservoirs are fitted with sight glasses to check the fluid level inside the reservoir. To check the fluid level in the reservoir, you can look through the inspection window via the slot located on the front right-hand side of the handlebar cover (front brake); for the combined brake, it is located on the left-hand side of the handlebar. If the brake fluid level is low or insufficient, **NEVER** top up the reservoir; instead, check the wear condition of the brake pads and discs and check for any leaks in the braking system.

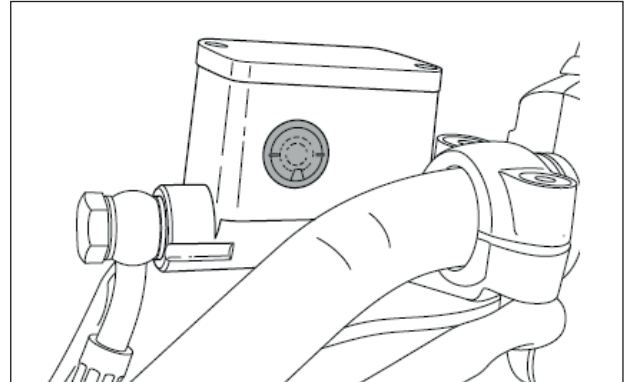

WARNING

Brake fluid is hygroscopic, meaning it absorbs moisture from the surrounding air. If the moisture content in the fluid exceeds a certain level, braking will be ineffective.

WARNING

It is advisable to have the fluid replaced every two years; never use brake fluid from containers that have already been opened or are partially used.

WARNING

Ensure that only DOT 4-grade brake fluid is used.

WARNING

Brake fluid is highly corrosive. Avoid contact with the skin or painted surfaces. In the event of contact with the skin, wash thoroughly with water.

eSpro 3 HEADLAMP

On the **eSpro 3** model, the headlight is fitted with an LED bulb and does not need to be replaced. If the bulb fails, the entire headlight must be replaced.

For replacement, please contact an authorised service centre..

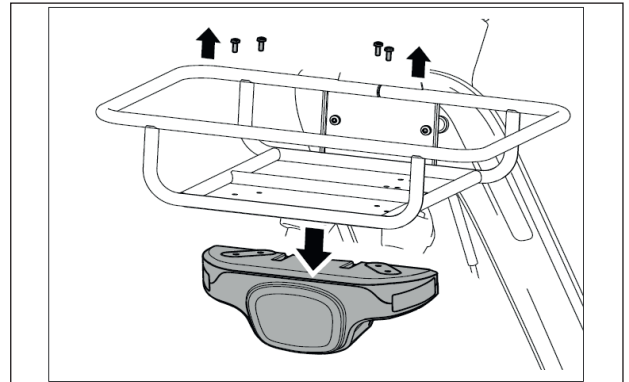

REAR LIGHT CLUSTER AND eSpro 3 INDICATORS

The rear light cluster, the front and rear indicators and the number plate light are fitted with LED lights and are integrated into the vehicle's bodywork.

For replacement, please contact an authorised service centre.

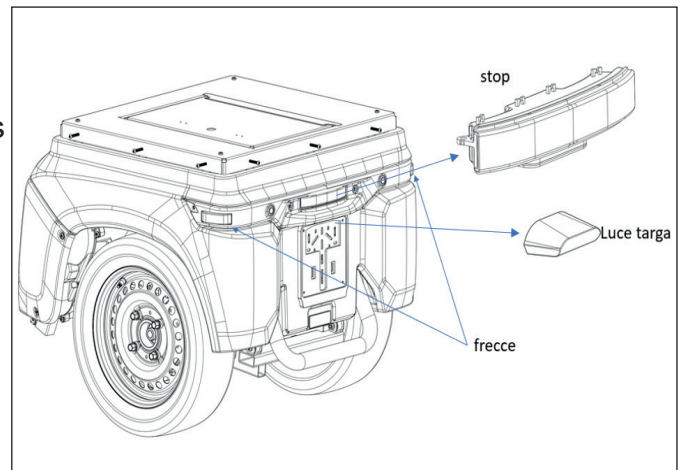

ADJUSTMENTS AND REGULAR MAINTENANCE

SUMMARY TABLE OF ROUTINE MAINTENANCE PROCEDURES

C: check; A: adjust; L: lubricate; R: replace

Year	1° Check	1 Year	2 Years	3 Years	4 Years	5 Years	6 Years	7 Years	8 Years	9 Years
Km x 1.000	2	6	12	18	24	30	36	42	48	54
Front/rear brake fluid (replace every 2 years)		C	S	C	S	C	S	C	S	C
Brake pad wear front/rear	C	C/S	C/S	C/S	C/S	C/S	C/S	C/S	C/S	C/S
Check front/rear brake discs	C	C/S	C/S	C/S	C/S	C/S	C/S	C/S	C/S	C/S
Poly-V first-stage drive belts (1 x motor)	C	C	S	C/S	S	C/S	S	C/S	S	C/S
Second-stage toothed drive belts (1 x motor)	C	C	S	C/S	S	C/S	S	C/S	S	C/S
Check the rear pulleys, inner and outer primary, and the secondary pulleys on the rear wheels	C	C	C	C	S	C	C	C	S	C
Nuts, bolts and fasteners/ rear body bolts (non-adjustable)	C	C	C	C	C	C	C	C	C	C
Steering bearings	C		C		C		C		C	
Front tyre/rear tyres	C	C/S	C/S	C/S	C/S	C/S	C/S	C/S	C/S	C/S
Front fork/rear shock absorbers	C	C	C	C	C	C	C	C	C	C
Inspection of electrical equipment and the electrical system	C	C	C	C	C	C	C	C	C	C
Checking rear parking sensors	C	C	C	C	C	C	C	C	C	C
Parking brake hoses and swing brake hoses	C	C	C	C	S	C	C	C	S	C
Electric parking brake	C/R	C/R	C/R	C/R	C/R	C/R	C/R	C/R	C/R	C/R
Combined foot brake	C	C	C	C	C	C	C	C	C	C
Tilting hinge system	C	C	C	C	C	C	C	C	C	C

NOTE: At 2,000 km, ALWAYS carry out the first vehicle inspection. Service intervals: services must be carried out within the specified mileage. If the specified mileage is not reached, we recommend that the vehicle undergoes an **annual service** inspection regardless.

ADJUSTMENTS AND REGULAR MAINTENANCE

VEHICLE CLEANING

To prevent rusting, wash the vehicle every time it is used in specific weather or road conditions, such as roads treated with salt or de-icing agents during the winter, or in areas with high levels of air pollution, such as cities, industrial areas, or areas with high salinity or humidity, including coastal regions.

Ensure that dirt, industrial dust, dead insects, bird droppings, etc. do not remain on the bodywork for long periods.

Use a low-pressure water jet to loosen dirt from painted surfaces, then remove it with a soft car wash sponge soaked in plenty of water and shampoo, and finally rinse and dry with a chamois leather.

Avoid washing the scooter in direct sunlight, especially in summer, to prevent the bodywork from heating up and drying the shampoo immediately before rinsing, as this could damage the paintwork.



Do not use high-pressure water jets for washing, to avoid damaging the vehicle's delicate components.



When washing, never direct the water jet directly at delicate components such as electrical wiring and its connections.



Never use cloths soaked in petrol, alcohol or potentially corrosive liquids to clean painted surfaces, plastics or the seat cover, as this may cause the materials to lose their shine and mechanical properties, or result in damage.



Scooters must be washed in areas equipped to collect and treat the liquids used.

VEHICLE IDLING

When preparing for a long period of inactivity, it is advisable to:

- charge the batteries to 100%
- give the vehicle a thorough clean,
- store the vehicle in a covered area,
- cover the vehicle with a tarpaulin.

ERROR CODE

ECU error codes

<p>Dashboard/ECU communication error: Communication issues have been detected between the vehicle's electronic control units, specifically between the dashboard and the ECU. We recommend taking the vehicle to an authorised workshop.</p>	E001
<p>Error with charging plug sensor: If you notice any problems with the charging socket, check that the charging cable is connected. The charging indicator light is flashing rapidly.</p>	E002
<p>Error due to throttle failure: If a fault is detected with the throttle, we recommend cleaning the connector first; if the problem persists, have the accelerator replaced at an authorised workshop.</p>	E003
<p>Error due to a fault with the headlight: If a fault is detected with the headlight, we recommend taking the vehicle to an authorised workshop.</p>	E004
<p>Error due to a fault with the front left indicator: If a fault is detected with the front left indicator, we recommend taking the vehicle to an authorised workshop.</p>	E005
<p>Error due to a fault with the front right indicator: If a fault is detected with the front right indicator, we recommend taking the vehicle to an authorised workshop.</p>	E006
<p>Error due to a fault with the left rear indicator: If a fault is detected in the left rear indicator, we recommend taking the vehicle to an authorised workshop.</p>	E007
<p>Error due to a fault with the right rear indicator: If a fault is detected with the right-hand rear indicator, we recommend taking the vehicle to an authorised workshop.</p>	E008

ECU error codes

Error due to rear brake light failure: If a fault is detected with the rear brake light, we recommend taking the vehicle to an authorised workshop.	E009
Error due to a faulty rear light: A fault has been detected with the rear light or number plate light. We recommend that you take the vehicle to an authorised workshop.	E010
Error due to a fault in the 12V horn: If a fault is detected with the horn, we recommend that you take the vehicle to an authorised workshop.	E011
Error due to a 12V fault in the dashboard: If a malfunction is detected in the dashboard, we recommend taking the vehicle to an authorised workshop.	E013
Error due to a 12V fault in the handlebar controls: If a fault is detected in the handlebar controls, we recommend that you take the vehicle to an authorised workshop.	E014
Error due to a fault in the parking brake release button: If a fault is detected with the parking brake button, we recommend taking the vehicle to an authorised workshop.	E015
Error due to AUX output failure: If a fault is detected at the AUX output or the USB port is not working properly, we recommend taking the vehicle to an authorised workshop	E016
Error due to a fault in the tamper-proofing system: A fault has been detected in the anti-tampering system; an incorrect inverter or ECU has been fitted to this vehicle. We recommend that you take the vehicle to an authorised workshop	E017

ERROR CODE

ECU error codes

<p>Immobiliser activated: The vehicle immobiliser is detected as active; the vehicle has been remotely locked.</p>	E018
<p>Steering lock engaged: The system detects that the steering lock is engaged; this may occur if the vehicle is started remotely. We recommend taking the vehicle to an authorised workshop.</p>	E019

RIGHT-HAND POWERTRAIN FAULT CODES

<p>Fault in the Hall sensors of the right-hand motor: If a fault is detected in the Hall sensors of the right-hand engine, we recommend taking the vehicle to an authorised service centre</p>	E020
<p>High motor temperature detected (right): If the right-hand engine is found to be overheating, we recommend that you stop the vehicle; if the problem persists, take the vehicle to an authorised workshop.</p>	E021
<p>Fault in the right-hand motor temperature sensor: A fault has been detected in the right-hand motor temperature sensor; we recommend taking the vehicle to an authorised workshop.</p>	E022
<p>Fault in the thermal sensor of the right inverter: If a fault is detected in the right inverter's temperature sensor, we recommend taking the vehicle to an authorised workshop.</p>	E023
<p>Fault in the right-hand motor control of the inverter: If a fault is detected in the control system of the inverter's right-hand motor, we recommend taking the vehicle to an authorised workshop.</p>	E024

RIGHT-HAND POWERTRAIN FAULT CODES

Fault in the right-hand control of the inverter: If a fault is detected in the right-hand control of the inverter, we recommend taking the vehicle to an authorised service centre	E025
High temperature detected in the right inverter: If an right inverter overheating fault is detected, we recommend that you stop the vehicle; if the problem persists, take the vehicle to an authorised workshop.	E026
Communication error detected in the right inverter: If a right inverter communication error is detected, we recommend taking the vehicle to an authorised workshop.	E027

LEFT-HAND POWERTRAIN FAULT CODES

Fault in the left-hand motor Hall sensors: A fault has been detected with the left-hand motor Hall sensors; we recommend taking the vehicle to an authorised workshop.	E030
High temperature detected in the left motor: If an overheating fault is detected in the left motor, we recommend that you stop the vehicle; if the problem persists, take the vehicle to an authorised workshop.	E031
Fault detected in the left motor temperature sensor: A fault has been detected in the left motor temperature sensor; we recommend taking the vehicle to an authorised workshop.	E032
Fault detected in the thermal sensor of the left-hand inverter: A fault has been detected in the thermal sensor of the left-hand inverter; we recommend taking the vehicle to an authorised workshop.	E033

ERROR CODE

LEFT-HAND POWERTRAIN FAULT CODES

<p>Fault detected in the control circuit of the left-hand inverter motor: If a fault is detected in the control system of the left-hand inverter motor, we recommend taking the vehicle to an authorised workshop.</p>	E034
<p>Fault detected in the left-hand inverter control: If a fault is detected in the left-hand inverter control unit, we recommend taking the vehicle to an authorised service centre.</p>	E035
<p>Over-temperature detected in left-hand inverter: If an over-temperature fault is detected in the left-hand inverter, we recommend switching off the vehicle; if the problem persists, take the vehicle to an authorised service centre.</p>	E036
<p>Communication error detected in the left-hand inverter: If a communication error is detected in the left-hand inverter, we recommend taking the vehicle to an authorised service centre.</p>	E037

BATTERY ERROR CODES

<p>Battery short circuit detected: If a battery short circuit is detected, we recommend having the condition of the batteries checked at an authorised service centre.</p>	E050
<p>A fault has been detected in the BSM battery temperature sensor: If a fault is detected in the battery BSM temperature sensor, we recommend that you take the vehicle to an authorised service centre.</p>	E051
<p>Excessive/insufficient battery temperature detected: If an excessive/insufficient battery temperature is detected, we recommend disconnecting the batteries, waiting a few minutes and reconnecting them to the vehicle. If the excessive/insufficient temperature warning persists, we recommend taking the vehicle to an authorised service centre.</p>	E052

EXPANDER ERROR CODES

Fault with the parking brake: If a fault is detected in the parking brake, we recommend taking the vehicle to an authorised service centre	E090
Internal fault in the I/O expander: If an internal fault is detected in the I/O expander, we recommend taking the vehicle to an authorised service centre.	E091
I/O expander fan power supply fault detected: A fault has been detected in the power supply to the I/O expander cooling fan, located behind the nameplate. We recommend that you take the vehicle to an authorised service centre.	E092
Power supply fault detected for I/O expander parking sensor: If a power supply fault is detected in the I/O expander parking sensor, we recommend taking the vehicle to an authorised service centre.	E093
Power supply fault detected in the boot opening system: If a fault is detected in the boot opening system's power supply, we recommend that you take the vehicle to an authorised service centre.	E094
I/O expander communication error detected: If an I/O expander communication error is detected, we recommend taking the vehicle to an authorised service centre.	E095

TECHNICAL DATA

DIMENSIONS OF THE eSpro 3 VEHICLE

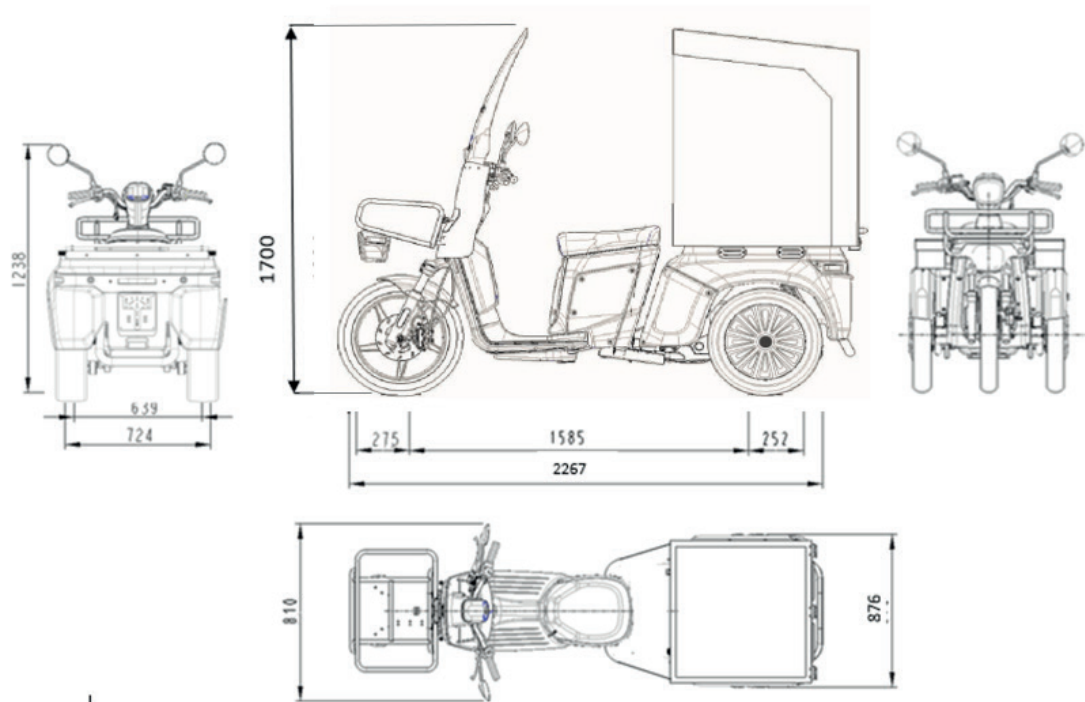

MODEL	eSpro 3
MOTOR DATA	
Model	Brushless permanent magnet sinusoidal motor
Motor type (2 engines)	EME 202 (belt-driven pulley system)
Regeneration	Automatic
Max power	2 motors, 4.1 kW each; total 8.2 kW * with 4 batteries connected and at equal charge levels in accordance with EU Regulation 168/2013, WMTC test cycle
Maximum torque at the wheel	2x155 Nm =310 Nm

BATTERIES	
Model	TC116 - Energy 6,8 kWh (4x1.7KWhr)
Voltage and capacity	54V - 126 Ah (4x31,5 Ah)
Power socket	Scame
Swappable	Yes
Charge	LI - ION
Weight of a single battery	8 kg (battery 1.7KW) tot. 32 kg (4x8)
Autonomy *	with 4 batteries, 1.7 kWh, 120 km range and energy consumption of 89.7 Wh/km with 4 batteries connected and at equal charge levels, according to the WMTC test cycle under EU Regulation 168/2013
Operating temperature	Operating temperature: -20 °C to +45 °C
Batteries number	4
Vehicle category	L5e-A

TECHNICAL DATA

MODEL	eSpro 3
VEHICLE DATA	
Length	2267 mm
Width at the steering wheel	810 mm
Rear width	876 mm
Wheelbase	1598 mm
Height of mirror mounts	1094 mm
Total height including windscreen	1700 mm
Height at battery compartment level	770 mm
Saddle height	760 mm
Front tyre pressure	200+/-10 kPa (2 bar)
Rear tyre pressure	200+/-10 kPa (2 bar)
Front tyre size	90/80-16, 45J, wheel rim 16"x2,15"
Rear tyre size	145/60-13, 51J, wheel rim 13"x4.00B
Vehicle weight in running order	204 kg
Frame	Tubular
Maximum permissible weight	420 Kg (vehicle + driver + additional load)
Maximum permissible weight for the rear body	60 Kg (10 on the upper floor + 50 on the lower floor)
Maximum permissible load on the front luggage rack	20 kg, centred on the roof rack
Seat	1 seat
Transmission	Mixed poly-V and toothed belts
Maximum speed	Speed limit: 65 km/h
Reverse speed	Speed limit: 4 km/h

FRONT LIGHTING ASSEMBLY	
Headlight	LED
Direction indicators	LED
Dashboard lights	Colours LED

REAR LIGHT CLUSTER	
Tail light	LED
Stop light	LED
Direction indicators	LED
License plate light	LED

TECHNICAL DATA

MODEL	eSpro 3
CYCLING	
Front suspension	Hydraulic fork
Rear suspension	2 x spring shock absorbers
Central tilting system	+/- 35°
Brake system	Hydraulic system with integrated CBS
Front brake	Disc 220mm
Rear brakes	2 x disc 190mm

MODEL	eSpro 3
GENERAL INFORMATION	
Connettivity	Present
Parking brake	Electric
Reverse	Yes, with a visual and audible indicator
External door	USB/USBc (12V)
Parking sensor	Optional (to be requested at the time of purchase)

ACCESSORY	
Rear box	h=1020mm, L= 860mm, P= 817mm
Front basket	L= 420mm, P= 330mm
Postal bag	Available
Front top box	Optional

VEHICLE COLOUR	
	Yellow PANTONE 3965C

Autonomy *	<p>The stated range is based on the WMTC (World Motorcycle Test Cycle) certification cycle; it is not a fixed value and may not correspond to actual driving experience on the road. WMTC tests are conducted under standardised laboratory conditions and may not reflect real-world conditions, leading to a discrepancy, with the actual range in some cases being up to 30% lower than the type-approval figures.</p> <p>Factors affecting actual range:</p> <ul style="list-style-type: none"> • Driving style: Rapid acceleration and high speeds significantly reduce the range. • Weather conditions: Extreme temperatures (very cold or very hot) have a negative impact on the vehicle's range. • Speed: Range drops significantly when driving constantly at top speed; under these conditions, the actual range may be considerably lower than the stated figure. • Road conditions and route: Urban or rural routes, as well as uphill and downhill sections, affect fuel consumption.
------------	--

GENERAL WARRANTY TERMS AND CONDITIONS

1. Contents of the standard warranty

- 1.1. Askoll EVA s.r.l., a single-member company with its registered office at Via Industria, 30, 36031 Dueville (VI), Italy, tax number and Vicenza Register of Companies number 03873430247 (hereinafter referred to as “Askoll”), a company forming part of the group managed and coordinated by Askoll Holding S.r.l., warrants that every electric vehicle manufactured by it (hereinafter referred to as the “Electric Vehicle”), including the related Askoll-branded components and accessories, is free from defects in design and/or manufacture (hereinafter referred to as the “Warranty”) in accordance with these terms and conditions (hereinafter referred to as the “Warranty Conditions”).
- 1.2. The Warranty shall commence at 00:00 on the day of delivery of the Electric Vehicle by the authorised Askoll sales outlet to the first purchaser (hereinafter referred to as the “Customer”) and shall have a duration of:
- (a) 12 (twelve) months for Electric Vehicles sold to Customers other than consumers, such as professionals, legal entities and private or public bodies (hereinafter referred to as the “Professionals”).
 - (b) 24 (twenty-four) months for Electric Vehicles sold to Customers classified as “consumers” pursuant to Legislative Decree No. 206 of 6 September 2005 (hereinafter the “Consumer Code”) or applicable national legislation (hereinafter, for brevity, the “Consumers”).
- The warranty excludes components of the Electric Vehicle subject to wear and tear such as, by way of example only: tyres, belts, flexible hoses, friction parts such as brake pads, vehicle batteries if not properly maintained, etc. This duration shall apply both to Customers classified as “consumers” within the meaning of Legislative Decree No. 206 of 6 September 2005 (hereinafter the “Consumer Code”) and to Customers other than consumers, such as professionals, legal entities and private or public bodies. The Warranty shall be considered valid solely and exclusively if the end-user Customer carries out the correct maintenance of the vehicle in their possession by performing the operations described in the Maintenance Schedule set out in the Owner’s Manual.
- These activities must be carried out at service centres authorised by Askoll and the work must be recorded by the authorised centre in this manual and on the dedicated portal. The Warranty shall be considered valid only if the Customer-user carries out the correct maintenance of the vehicle in their possession by performing the operations described in the Maintenance Schedule set out in the User and Maintenance Manual. These activities must be carried out at service centres authorised by Askoll and the work must be recorded in this manual.
- 1.3. The validity of the Warranty, in the event of a transfer of ownership of the Electric Vehicle, continues regardless of any change in ownership of the vehicle itself, subject to the conditions set out in these Warranty Terms and Conditions.
- 1.4. Where a design and/or manufacturing defect is found, reported in accordance with the Warranty Conditions, the Customer is entitled to have the defect repaired free of charge through the Askoll service network.
- 1.5. Askoll shall bear the costs of repairs or replacements of defective parts and the labour required for such repairs or replacements. The choice of remedy between repair or replacement (which may be carried out using reconditioned parts, where technical specifications permit, or new parts) shall be at Askoll’s discretion depending on the extent of the defect and the cost-effectiveness of one remedy over the other, subject to compliance with the quality, safety and reliability of the repair or replacement itself. Should the repair of the defect be impossible, excessively costly or, finally, of uncertain outcome, Askoll may replace the electric vehicle free of charge with a brand-new one of the same model and specification as the item being replaced.
-

GENERAL WARRANTY TERMS AND CONDITIONS

1. Contents of the standard warranty

- 1.6. If, during the repair, it transpires that the work is not covered by the warranty, the cost of the repair must be borne in full by the owner of the vehicle.
- 1.7. Defective parts replaced under warranty become the property of Askoll.
- 1.8. The time taken to carry out the repair does not extend the warranty period. Repair and/or replacement work, as well as new parts replaced under warranty or repaired whilst the statutory warranty is in force, does not trigger a new two-year limitation period for the replaced part, but the period relating to the first delivery of the goods continues to run, depending on the duration of the warranty period applicable to the first purchaser of the Electric Vehicle being repaired. If, however, the spare part is replaced after the expiry of the statutory warranty period for the complete product, the replaced part shall be covered by the two-year statutory warranty from the date of delivery or installation. In essence, the statutory warranty applies to 'spare parts' only if the replacement of such parts takes place outside the warranty period.
- 1.9. The Warranty does not cover the mobility service.

2. Exclusions

- 2.1. Routine maintenance services for the Electric Vehicle are excluded from the Warranty.
- 2.2. Components of the Electric Vehicle subject to loss of efficiency, wear and tear or deterioration resulting from the normal use or operation of the Electric Vehicle (such as, by way of example only: tyres, belts, flexible hoses, friction parts such as brake pads, and the vehicle battery) are excluded from the Warranty.
- 2.3. The Warranty does not apply to defects other than or unrelated to those of design or manufacture; therefore, the Warranty specifically excludes, by way of example only, any repairs or replacements for faults and/or malfunctions caused by or arising, directly or indirectly, from:
 - a) fortuitous events or force majeure (such as, by way of example only: oxidation or other phenomena caused by atmospheric agents due to environmental conditions or circumstances outside the norm);
 - b) use of the Electric Vehicle that is non-compliant or otherwise contrary to the requirements, warnings and recommendations set out in the User and Maintenance Manual (including, by way of example, incorrect washing of the electric vehicle in accordance with the instructions contained therein);
 - c) modifications, repairs or other interventions that do not comply with the standards for modification, repair or disassembly prescribed by Askoll;
 - d) fitting of parts and/or spare parts that do not comply with those prescribed or whose use has not been approved by Askoll;
 - e) improper use of the Electric Vehicle or use other than for private purposes (such as, for example, use in sporting competitions of any kind or use in rental services, public transport, etc.);
 - f) wilful misconduct, negligence, incompetence or recklessness on the part of the owner or driver.
 - g) accidents, such as collisions with other vehicles, persons, animals, objects (whether identified or not), rollovers, running off the road, acts of vandalism;
 - h) external causes and/or foreign objects (such as, by way of example only: punctured tyres, broken windows, etc.);

GENERAL WARRANTY TERMS AND CONDITIONS

2. Exclusions

- i) normal wear and tear of the Electric Vehicle resulting from its use, meaning the loss of efficiency, deterioration and wear and tear that any material, component, part or mechanical element undergoes solely as a result of prolonged use; wear and tear is identified by comparing the condition, mileage and duration of use observed on the damaged parts with the potential average service life normally attributed to them; where necessary, the assessment shall be carried out by an expert.

3. Customer's obligations

- 3.1. The Warranty shall apply only if the lack of conformity has been reported, in writing, by the Consumer Customer no later than 2 (two) months after discovery and by the Business Customer no later than 8 (eight) days after discovery.
- 3.2. The Customer is responsible for reporting the lack of conformity within the aforementioned time limits by contacting authorised Askoll sales outlets listed on the Askoll website <http://askollelectric.com>.
- 3.3. The Customer must present a copy of the proof of purchase (receipt or invoice) or other supporting document demonstrating the validity and applicability of the Warranty.
- 3.4. In the event of failure to comply with the provisions of the preceding paragraphs, the Warranty shall not apply and the Customer shall forfeit the right to the relevant services.
- 3.5. The validity of this Warranty, in the event of a transfer of ownership of the Electric Vehicle, continues regardless of the change in ownership of the vehicle itself, subject to the new purchaser's obligation to present the proof of purchase from the original purchaser. The new owner is, in any case, requested to notify Askoll promptly of the change in ownership of the electric vehicle using the procedures available on the Askoll website www.askoll.com or <http://askollelectric.com>, also to enable Askoll to provide targeted communication in the event of any safety-related recalls or updates to certain components.
- 3.6. The Warranty does not cover mobility services; therefore, the Customer must deliver the Electric Vehicle, at their own expense, to an authorised Askoll sales outlet or, subject to prior telephone agreement, directly to authorised service centres. Upon specific request, a collection service for the Electric Vehicle from the Customer's home may be offered, with costs borne by the Customer, or assistance at the Customer's home, with call-out costs borne by the Customer. In exceptional cases, where the fault covered by the Warranty renders the motorcycle unable to be ridden, the costs of collecting the motorcycle or of home assistance shall be agreed in advance with Askoll.
- 3.7. The Customer must cooperate to ensure the smooth running of the assistance activities, providing the Askoll service network with any information regarding the circumstances in which the defect occurred, as well as any information and clarifications that Askoll, either directly or through the service network, may request.
- 3.8. The Warranty applies to faults identified by Askoll through its service network; should Askoll not consider the Warranty to be applicable and a dispute arise with the Customer, repair work shall be suspended pending an expert assessment.
- 3.9. The Warranty shall be considered valid only if the end-user Customer carries out the correct maintenance of the vehicle in their possession by performing the operations described in the Maintenance Schedule. These activities must be carried out at service centres authorised by Askoll and the work must be recorded in this booklet and on the portal made available to the authorised service centres.

GENERAL WARRANTY TERMS AND CONDITIONS

4. Limitation of liability

- 4.1. Subject to the provisions of mandatory national legislation applicable to the relationship between the “consumer” and the manufacturer, and the provisions on the manufacturer’s civil liability, Askoll shall not be liable for damage to property and/or persons caused in any way by the Electric Vehicle, its use, its malfunction or its immobilisation due to faults.
- 4.2. Any downtime of the Electric Vehicle or delays in repairs or replacements relating to the Electric Vehicle entrusted to the Askoll service network shall not entitle the customer to any compensation or reimbursement of expenses (such as, for example, costs for replacement vehicles) from Askoll, nor to any extension of the Warranty.
- 4.3. No compensation shall be payable for loss of income resulting from the malfunction of the Electric Vehicle or other onerous consequences of the defect itself.

5. Nature of this warranty

- 5.1. This warranty is governed solely by these Warranty Terms and Conditions and by Italian law, without prejudice to the possible application of mandatory provisions for the protection of consumers provided for by the applicable legislation in the Customer’s country of residence classified as a “consumer” pursuant to Legislative Decree No. 206 of 6 September 2005 of the Italian Republic (hereinafter the “Consumer Code”) or pursuant to similar codes or similar national legislation applicable in the Customer’s country of residence (hereinafter, for brevity, the “Consumer Customers”).
- 5.2. This Warranty is a contractual warranty within the meaning of Article 133 of the Consumer Code.
- 5.3. This Warranty, together with the Warranty Terms and Conditions, constitutes the sole contractual warranty offered by Askoll in its capacity as manufacturer of Askoll-branded electric vehicles.
- 5.4. These Warranty Terms and Conditions are without prejudice to the mandatory rights against the seller recognised for the natural person defined as a “consumer” under the Consumer Code or under applicable national legislation.
- 5.5. Except in the case of a Consumer Customer or where otherwise provided for by a mandatory provision in force in the Customer’s country, the Court of Vicenza, Italy, shall have exclusive jurisdiction over any disputes relating to these Warranty Terms and Conditions.

GENERAL WARRANTY TERMS AND CONDITIONS

6. Scooter service logbook

Owner	Date:	Service inspection within 2000 Km	
Surname:		Mileage	Next Service
Name:		Dealer's stamp	
Work carried out:			

Owner	Date:	Service inspection within 6000 Km	
Surname:		Mileage	Next Service
Name:		Dealer's stamp	
Work carried out:			

Owner	Date:	Service inspection within 12000 Km	
Surname:		Mileage	Next Service
Name:		Dealer's stamp	
Work carried out:			

GENERAL WARRANTY TERMS AND CONDITIONS

6. Scooter Servicing Log Book

Owner	Date:	Next service due within 18.000 Km	
Surname:		Mileage	Next Service
Name:			
Work carried out:		Dealer's stamp	

Owner	Date:	Next service due within 24.000 Km	
Surname:		Mileage	Next Service
Name:			
Work carried out:		Dealer's stamp	

Owner	Date:	Next service due within 30.000 Km	
Surname:		Mileage	Next Service
Name:			
Work carried out:		Dealer's stamp	

GENERAL WARRANTY TERMS AND CONDITIONS

6. Scooter Servicing Log Book

Owner	Date:	Next service due within 36.000 Km	
Surname:		Mileage	Next Service
Name:			
Work carried out:		Dealer's stamp	

Owner	Date:	Next service due within 42.000 Km	
Surname:		Mileage	Next Service
Name:			
Work carried out:		Dealer's stamp	

Owner	Date:	Next service due within 48.000 Km	
Surname:		Mileage	Next Service
Name:			
Work carried out:		Dealer's stamp	

GENERAL WARRANTY TERMS AND CONDITIONS

6. Scooter Servicing Log Book

Owner	Date:	Next service due within 54.000 Km	
Surname:		Mileage	Next Service
Name:			
Work carried out:		Dealer's stamp	

Owner	Date:	Next service due within 60.000 Km	
Surname:		Mileage	Next Service
Name:			
Work carried out:		Dealer's stamp	

Owner	Date:	Next service due within 66.000 Km	
Surname:		Mileage	Next Service
Name:			
Work carried out:		Dealer's stamp	

NOTE

EAN CODE

Numero di Serie

QR CODE

Askoll EVA SpA
Via Industria, 30
36031 Dueville (VI) Italia
Tel. 0444 930260
www.askollelectric.com

E3266500