



Askoll EVA S.p.A. – Company Profile

May 2019

Askoll Group

Global Industrial Footprint



€ 211.000.000
Total Turnover

€ 19.000.000
Total Investments

1.800
Staff

3
Business Areas

8
Countries

9
Manufacturing Plants

11
Companies

Askoll Group

Global Structure

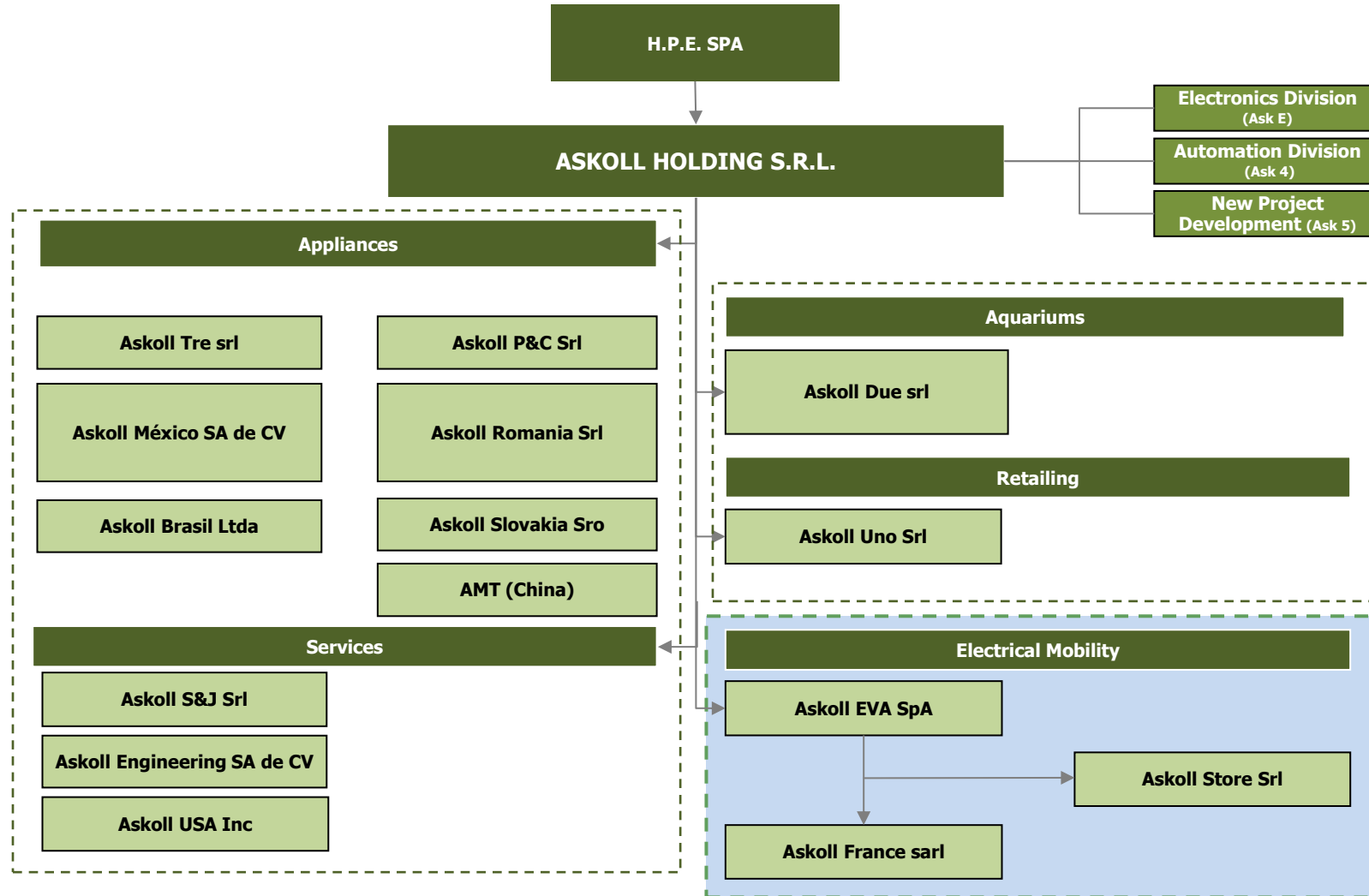

Askoll EVA

Milestone

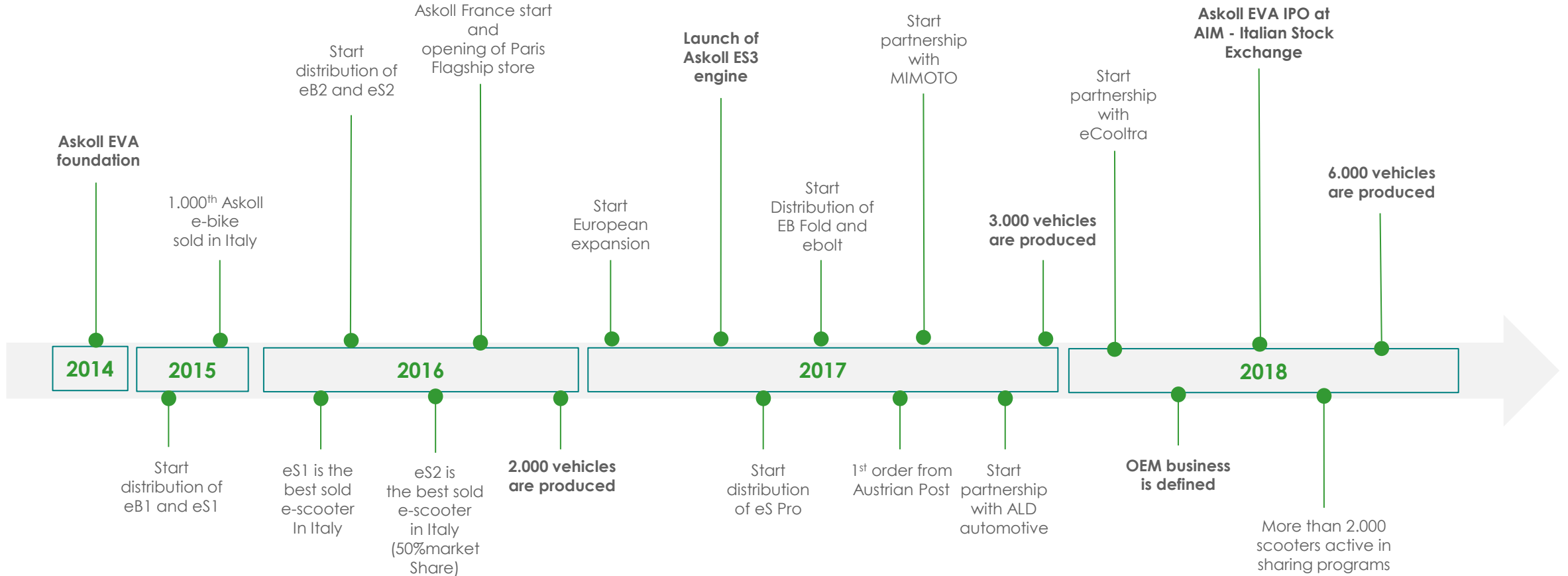

Askoll EVA Distribution Network

Askoll EVA distributes its solutions in

19 Countries through

+250 dealers and 11 independent
Distributors / Importers network

3 Askoll Store in Vicenza, Milan
and Paris

2 main branch: **Askoll Italy &
Askoll France**

Askoll
I am electric



Askoll EVA

Business partner

All core components are made by Askoll, in Italy

- Battery packs
- BMS
- Electronics
- Power train
- Highest quality
- Internal components development
- Taylor made solutions based on customer specification



Askoll EVA

Business partner

- Production capacity e-scooters:
30.000 / year
- Production capacity e-bikes:
20.000 / year
- Reliable lead time
- More than **30%** of production is related to specific customizations

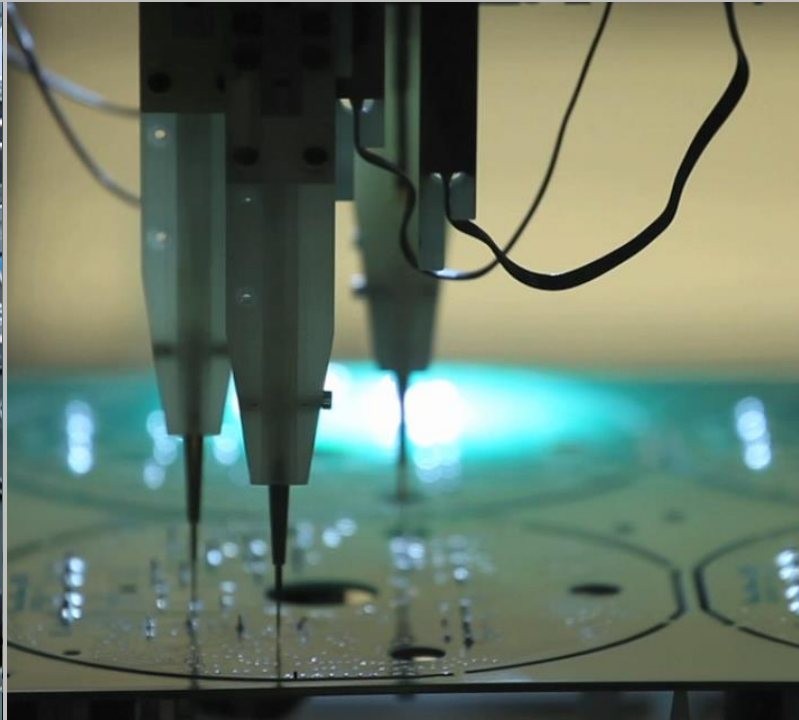

Askoll EVA

Business partner

- Qualify supplier and certificate
- Stock and storage of raw materials and product integrated in the production plant
- Direct connection with the professional customers for deliveries, assistance and quality control
- Time to deliver spare parts with highest service level



Askoll EVA

Product portfolio

Electrical Vehicles



Bike (Pedelec)

- Unisex, Man, Trekking, City, Folding, Kids, Kargo
- Private & professional range
- Sharing solutions
- Accessories



Scooter

- Vehicles type L1 / L3
- Private & professional range
- Sharing solutions
- Fleet solutions
- Accessories

OEM Solutions

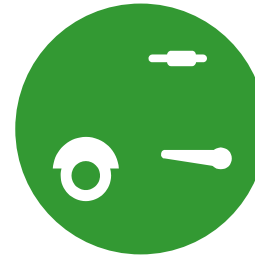

Off Field

- Battery
- Synchronous electric motor
- Gateway
- BMS
- ECU
- Power unit
- Electronic board
- Display



2 Wheels

- Battery
- Hub motor
- Bottom bracket motor
- Electronic board
- Display

Full electric solutions for urban sustainable mobility:

Individual



Professional



Sharing

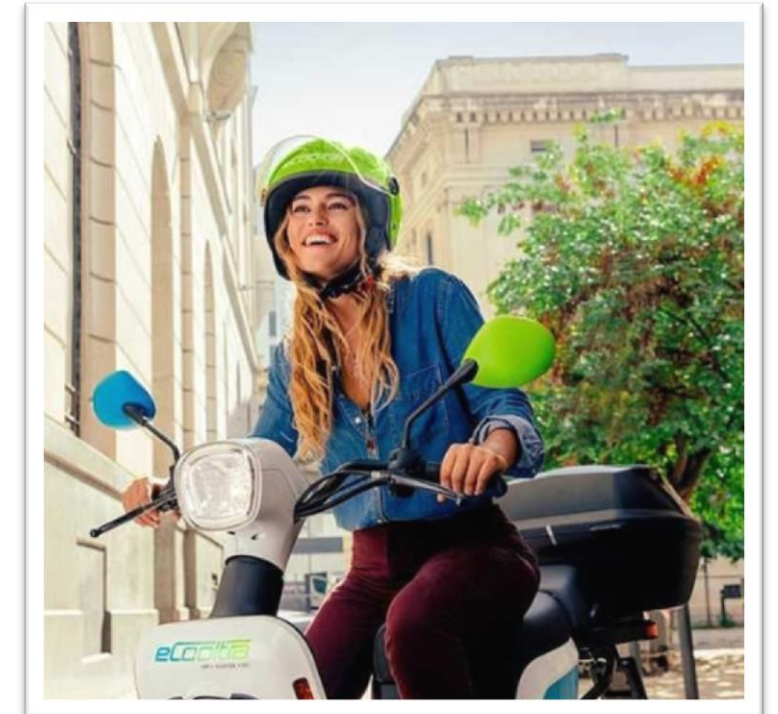

Askoll
I am electric

Bike range



Askoll EVA

Bike range



Engine and power train made by Askoll EVA

Electronic, development and production made by Askoll EVA



Indoor battery charge 350W made by Askoll EVA

Plug & play Battery



Ergonomics and lightness

Materials and design developed for everyday use

Askoll EVA

Bike range overview

Private

City, Urban, Sport, Folding, Kids. A complete Bike range for any needs and customers type



eB1 series



eB2 series



eB Folding series



eB4



eB5



eBolt

Professional

Professional Kargo bike for small/medium delivery and last mile



eB1 Kargo

Sharing

Sharing solutions for private and public programs



eB1 Sharing

Askoll
I am electric

Scooter range



Askoll EVA

Scooter range



Engine and power train made by Askoll EVA

Electronic, development and production made by Askoll EVA



Indoor battery charger 450W made by Askoll EVA

Extra battery pack



Fast and safe swapping connectors

2 Li-ion batteries with BMS made by Askoll EVA

Askoll EVA

Scooter range overview

Individual

A complete scooter range for cities and private users



eS1



eS2



eS3



eS2 / eS3
EVO

Professional

Professional delivery scooters: Food delivery, last mile, parcel and professional services



eS pro 45



eS pro 70



eS pro K1



eS pro K2

Sharing

Sharing solutions for public programs: standard & custom vehicles



eS2 Sharing
series



eS Sharing
Custom

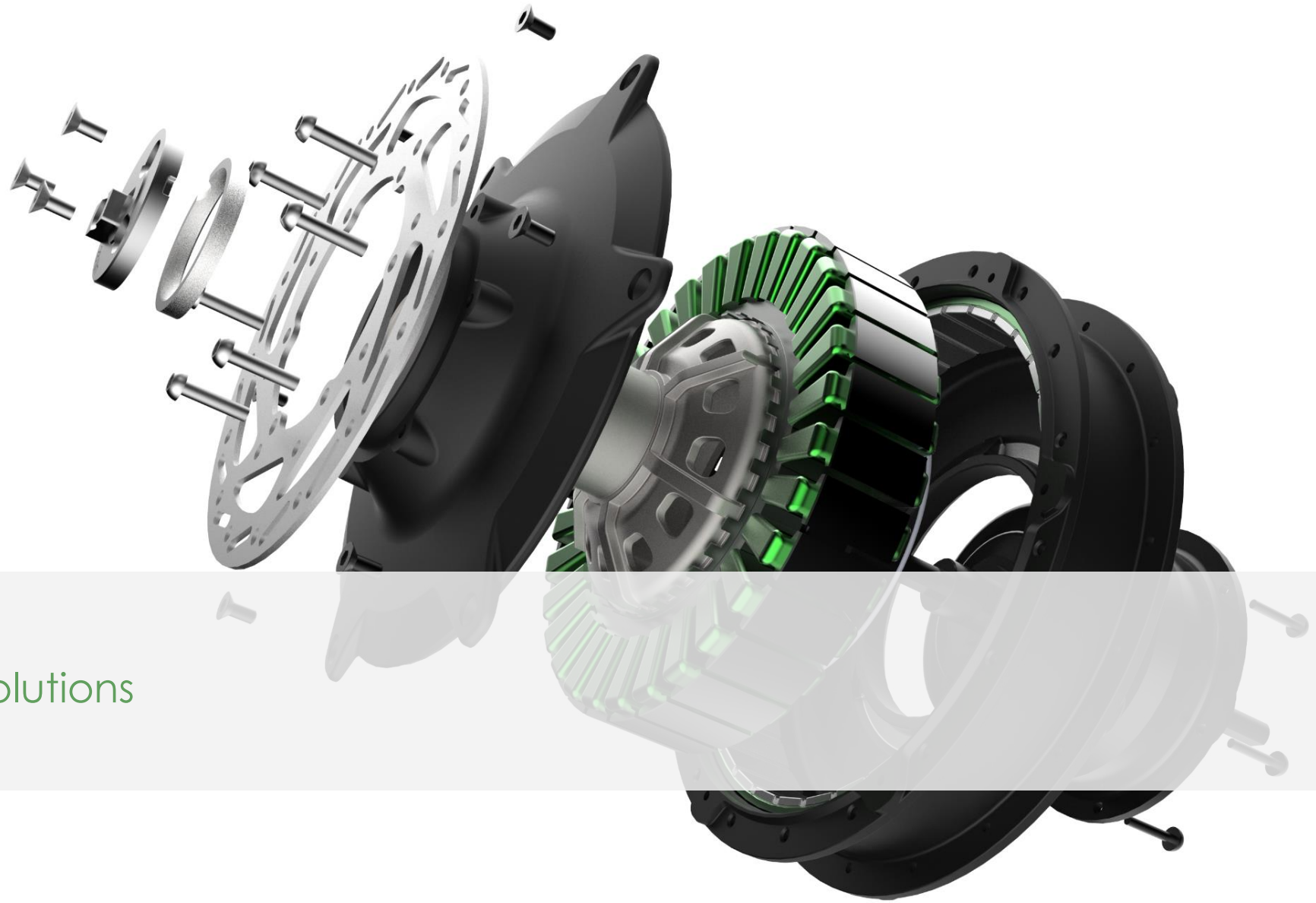

Askoll
I am electric

OEM solutions

OEM Solutions

CORE components for electrical market

We are already active with different solutions based on our know-how, in different sectors and markets

Our solutions could be fitted on 2 wheels market and off field applications

2 Wheels



Off Field

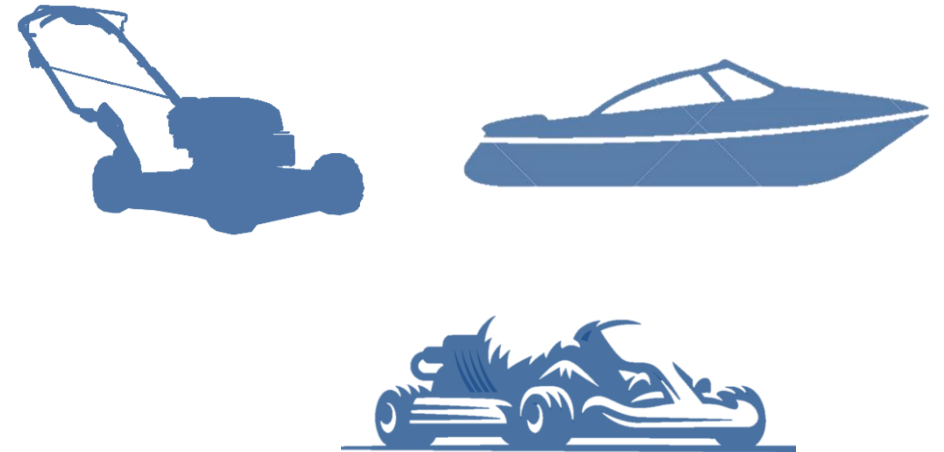

Askoll EVA

OEM Solutions

2 Wheels

CORE components for eBike and eScooter manufacturing



Bottom bracket motor



HUB Wheels motor



Motor up to 8.000W



Electronic board



Batteries



Power train



Display

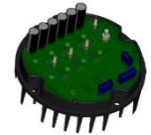

Driver

Off Field

CORE components for electric applications



Batteries



Power unit



Motor up to 8.000W



Electronic board and gateway

Askoll OEM



WHY ASKOLL WANTS TO DO IT

- It is our DNA
- We have a complete know-how
- We have the ability to follow specific customer needs



WHY YOU SHOULD CHOOSE ASKOLL

- Focus on quality
- Habit to work on volumes
- Knowledge on e-vehicles market

Askoll EVA

OEM Approach

Develop an **OEM offer** made of engine, battery pack, display and connectivity.

Develop and offer that transcend from the traditional markets segments.

We let **our** customers name **their** products.

A **flexible offer** that allows to combine the main kit components in the most efficient way.

Askoll
I am electric



100%

MADE IN ITALY



All Askoll vehicles born **100%** electric

All technical and core component (battery, control unit, power train and electrical engine) are made by Askoll

We are our first customers: all automation needed to produce and testing the vehicles is designed e produced by Askoll Group

We make solutions, in Italy

Askoll
I am electric

Thank you