

eS_{pro} 3

Professional Electric Vehicle

User's Manual, Maintenance, and Warranty

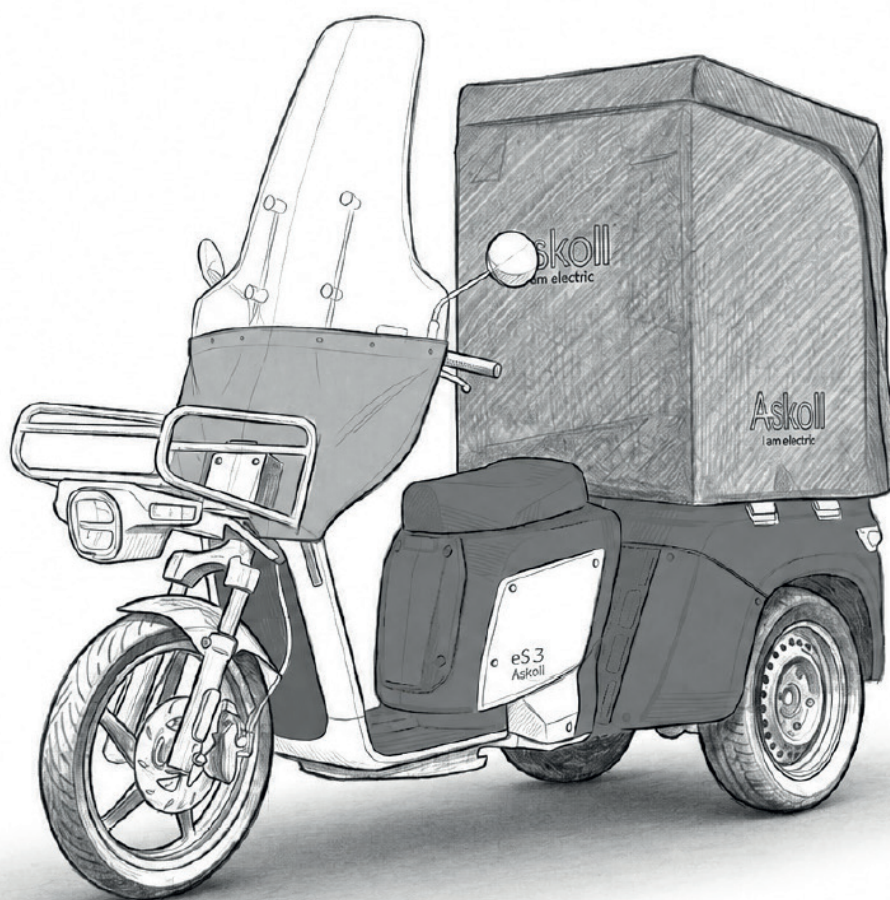

Askoll
I am electric

MADE IN ITALY

www.askollelectric.com



Welcome to the electric age!

With the purchase of the Askoll eSpro 3, you can finally enjoy a vehicle that combines the best of functionality, design, and technology from Askoll, a company with thirty years of experience in the design and manufacture of electric motors.

This manual has been prepared to allow you to fully appreciate its qualities. It contains information, warnings, and advice regarding the correct use and maintenance of your new vehicle.

It is important to read it in its entirety before driving the vehicle for the first time. You will also discover details and features that will help convince you of your excellent choice.

This publication is to be considered an integral part of the vehicle. If the vehicle is sold, it must be returned to the new owner.

Constant design evolution, to ensure the safety and quality standards of Askoll vehicles, may mean that some information in this Owner's Manual may differ from the actual vehicle you own. We are confident you will understand, therefore, that the data, illustrations, and descriptions contained herein cannot constitute the basis for any claims.

| | |
|--|--------------------------------------|
| INDEX | II |
| GENERAL INFORMATION | 1-2 |
| CONTROLS AND INSTRUMENTATION | 3-4-5-6-7-8-9 |
| USE | 10-11-12-13-14-15-16-17-18-19 |
| BATTERY AND CHARGING | 20-21-22-23-24-25-26-27-28 |
| ADJUSTMENTS AND PERIODIC MAINTENANCE | 29-30-31-32-33-34 |
| ERROR CODES | 35-36-37-38-39-40 |
| TECHNICAL DATA AND VEHICLE DIMENSIONS | 41-42-43 |
| GENERAL WARRANTY CONDITIONS (Contents of the conventional warranty) | 44 |
| GENERAL WARRANTY CONDITIONS (exclusions) | 45-46 |
| GENERAL WARRANTY CONDITIONS (Customer's responsibilities) | 46 |
| GENERAL WARRANTY CONDITIONS (Limitations of Liability) | 47 |
| GENERAL WARRANTY CONDITIONS (Nature of this warranty) | 47 |
| GENERAL WARRANTY CONDITIONS (Maintenance booklet, vehicle services) | 48-49-50-51 |

GENERAL INFORMATION

SIMBOLOGY

Particularly important information is highlighted throughout the manual that requires careful attention.

Each sign consists of a different symbol to highlight the content of the text that follows it and to facilitate the placement of topics in the various areas.

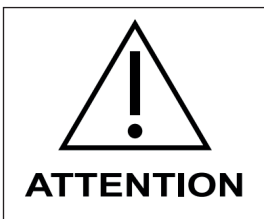

This symbol indicates particularly dangerous situations which, if not avoided, could result in death or serious injury.

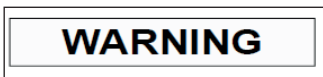

This version of the caution sign will be used throughout the manual.



This symbol indicates a general safety warning. It is used to alert you to potential dangers of injury to people and/or equipment.



Failure to comply with these instructions or their complete failure to do so may result in serious damage to the vehicle and, in some cases, the invalidation of the warranty.



The following guidelines are provided to avoid harming nature through vehicle use.

IMPORTANT SAFETY INFORMATION



**It's crucial for you to understand your electric vehicle:
Read and understand this manual before using it for the first time.**



**This operating manual is an integral part of the electric vehicle.
Keep it for future reference. If you sell the vehicle, it must be passed on to the subsequent owner.**



The scooter is not intended for use by persons with reduced physical, sensory, or mental capabilities, or who lack experience or knowledge, unless they have been given supervision or instruction concerning the use of the vehicle by a person responsible for their safety.

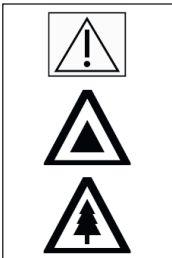

Failure to comply with these instructions or their incompleteness may result in serious damage to people, the vehicle, the environment, and in some cases, the warranty may be voided.



Any modification that modifies the performance or main structure of the vehicle, in addition to being prohibited by law, renders the vehicle no longer compliant with type approval and, therefore, a safety hazard.

IDENTIFICATION

The vehicle's serial numbers are stamped on the frame and in the compartment under the seat. They should always be indicated when ordering spare parts. It is advisable to check that the vehicle's serial numbers match those on the vehicle's documents.

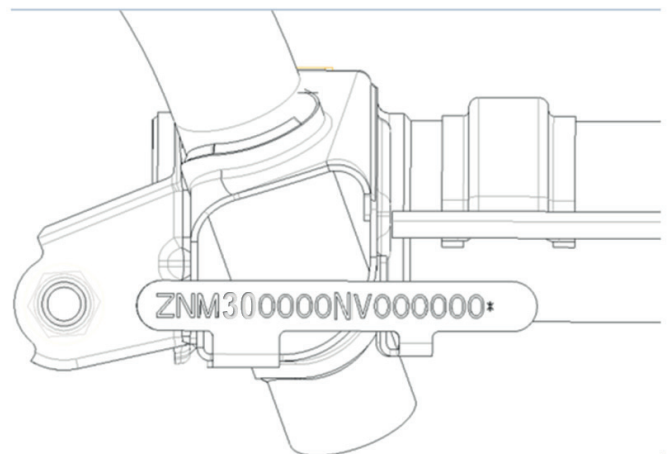
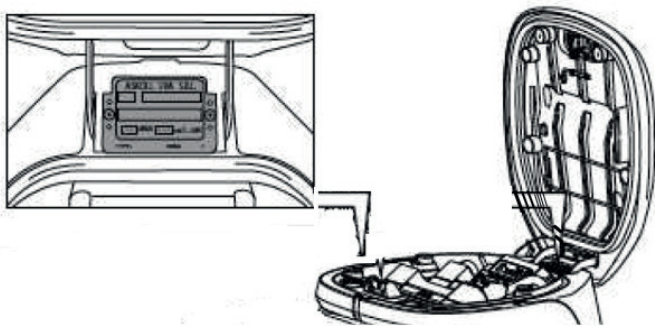

WARNING

Altering identification numbers can result in serious criminal penalties.

CONTROLS AND INSTRUMENTS

GENERAL VIEW OF THE VEHICLE

eSpro 3

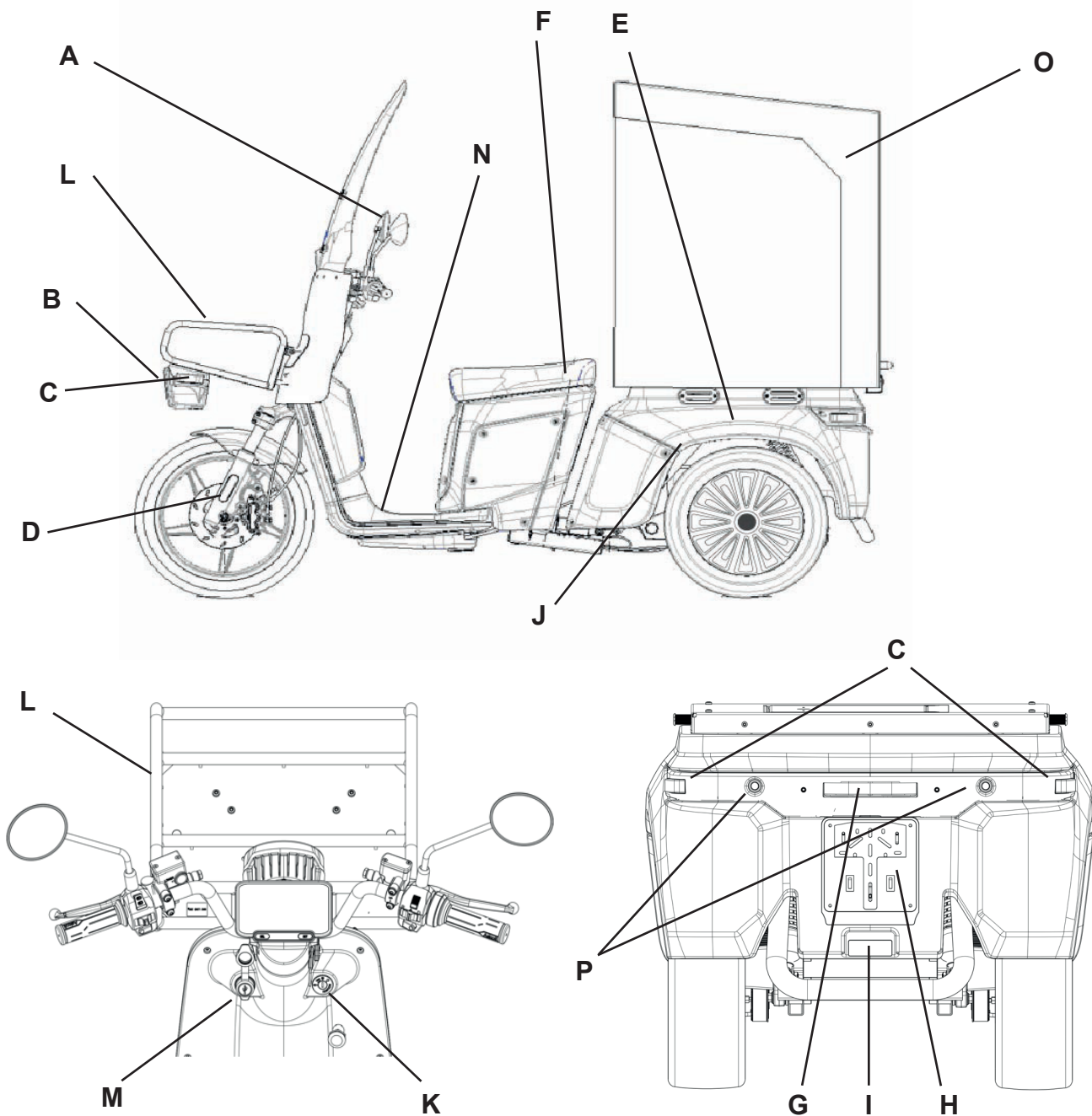

- A. Rearview mirror
- B. Headlight assembly
- C. Front/rear turn signals
- D. Front fork reflectors on the right and left sides
- E. Battery compartment and cargo box support base
- F. Saddle
- G. Rear light
- H. License plate holder

- I. Rear reflector
- J. 2 motors positioned on the RH and LH sides
- K. Ignition switch
- L. Front basket
- M. USB A/C port
- N. Combined foot brake
- O. Rear trunk
- P. Parking sensors

POSITION OF CONTROLS AND INSTRUMENTS

eSpro 3 CONTROL PANEL

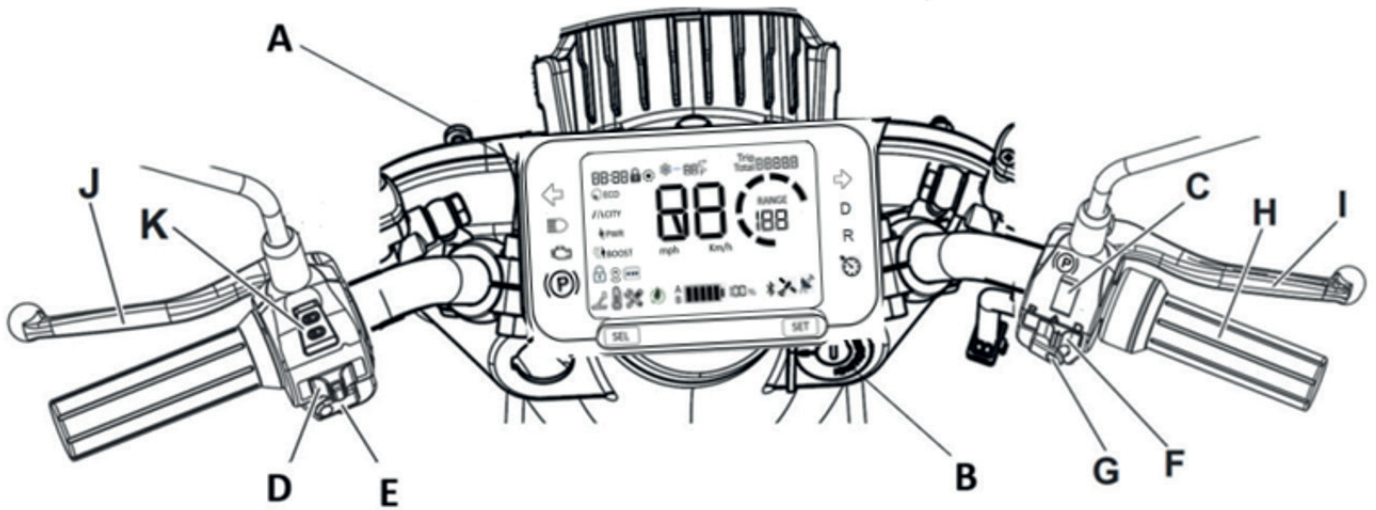

- A. Instrument panel
- B. Ignition switch
- C. Parking brake selector
- D. Turn signal switch
- E. Horn button
- F. Driving mode selector

- G. Motor start button
- H. Throttle control
- I. Front brake lever
- J. CBS combined brake lever
- K. Headlight switch

CONTROLS AND INSTRUMENTS

LEFT CONTROL GROUP

CBS combined brake lever

Rear brake lever with combined function acts primarily on the rear wheels and the front wheel, ensuring greater safety and better stopping distances.

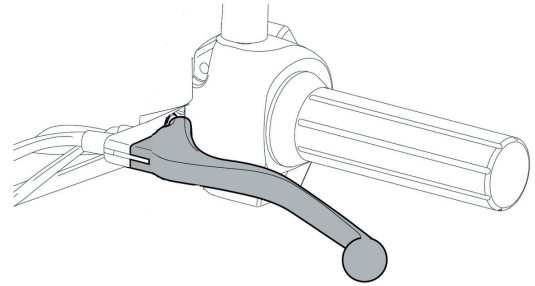

High beam headlight switch

Using the selector, you can activate the high beam light.

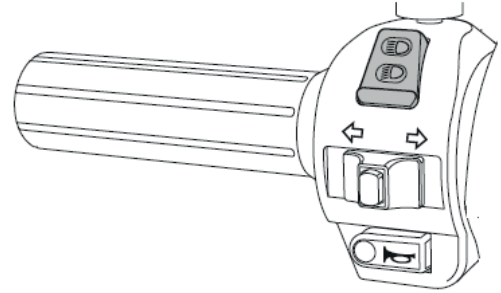

Indicator direction switch

Move the lever to the left to activate the left turn signals.

Move the lever to the right to activate the right turn signals.

Press the button in the center of the lever to turn off the turn signals.

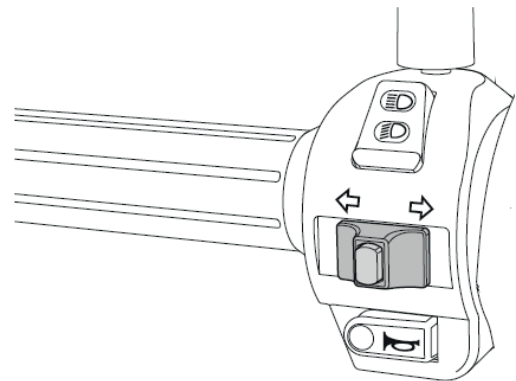

Horn button

Press to sound the horn.

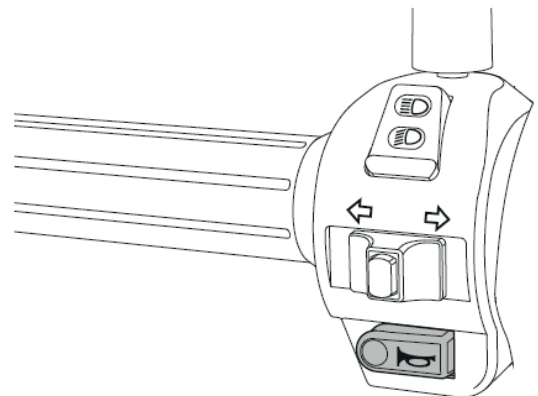

RIGHT CONTROL GROUP

Front brake control lever

The front disc brake lever is located on the right side of the handlebar and brakes the front wheel only

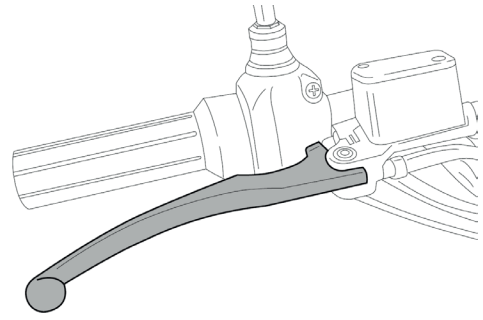

Throttle

The speed of the vehicle is adjusted by turning the knob.

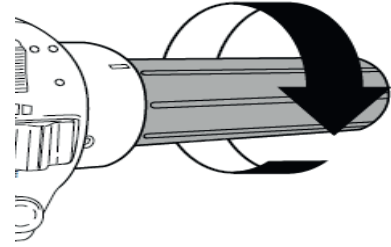

Electric parking brake control

The eSpro 3's electric parking control button is located on the left handlebar control.

The parking control button electrically locks both rear wheels and the tilt system, making it impossible to tilt the vehicle.

The locking system is released by pressing the button again.

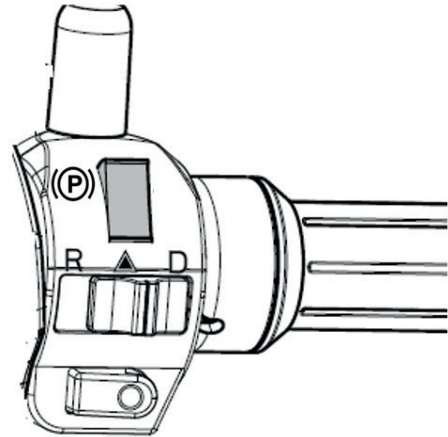

Warning: The parking control does not act as a brake while the vehicle is in use.

Driving mode selector

Using the switch, you can select the driving modes.

Position D = the front gear is engaged

Position ▲ = the 4 emergency flashers are activated (fig.1)

Position R = reverse gear is engaged

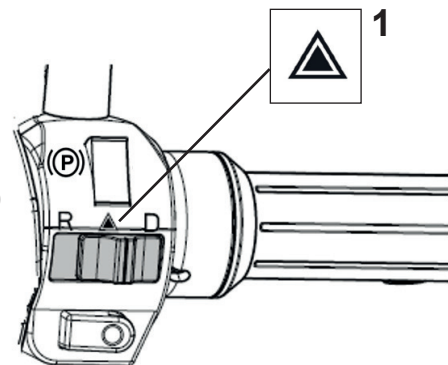

Reverse gear must be engaged with the vehicle completely stopped and with both feet on the ground. The maximum reverse speed is 4 km/h. During reverse, the hazard warning lights and the intermittent buzzer are automatically activated. If reverse gear is engaged incorrectly while driving forward, the vehicle will not hear the command. This is indicated on the dashboard by a flashing "R" next to the mileage indicator. The "D" gear indicator remains active, and the buzzer is activated continuously.

CONTROLS AND INSTRUMENTS

Motors start button

Pressing the button for 3 seconds, depending on the key position in the switch, enables or disables the motors.

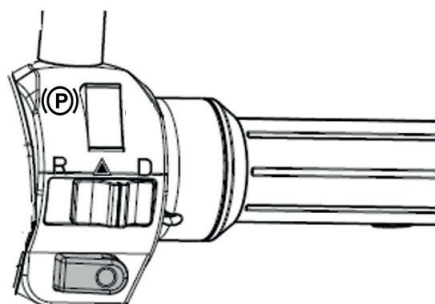

IGNITION KEY BLOCK

The ignition key enables or disables the engines and steering lock. The vehicle comes with a master key and a duplicate key, which can be used to both turn the ignition and open the seat. It is recommended to keep the duplicate key separate from the master key.

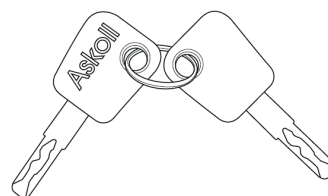

Enabling and disabling the system

Turning the key on  the system is enabled.

Turning the key on  the system is disabled.



WARNING

Do not turn or remove the key while driving.

PAIR OF KEYS SUPPLIED WITH THE VEHICLE

The keys supplied with the vehicle not only start the engine, but also open the underseat compartment (see paragraph on page 18), the battery compartment, and the rear trunk (see paragraphs on page 23).

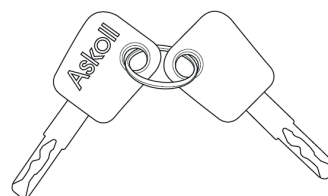

INSTRUMENTATION



- A. Warning lights
- B. Speedometer
- C. Digital display
- D. Display controls

WARNING LIGHTS

- H. Flasher indicators on
- L. Engine OBD diagnostic indicator
- K. High beam indicator on
- G. Parking brake and tilt lock indicator
- I. Forward gear indicator
- F. Charging indicator
- N. Reverse gear indicator on
- M. High temperature indicator

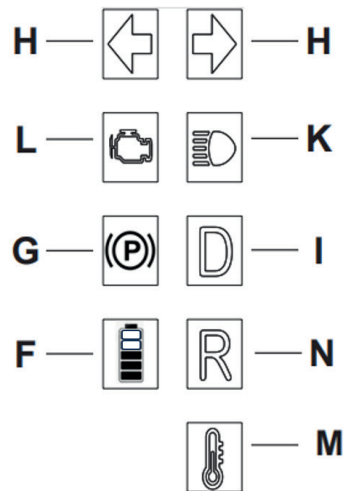

High temperature indicator

The high temperature indicator light is amber and turns on and remains lit to indicate an overtemperature alarm. The corresponding alarm code can be read on the display. For a description of the alarm related to the displayed code, refer to the “**ERROR CODES**” chapter.

Electric parking brake indicator and rocker lock

The electric parking brake and tilt system lock indicator light is active both when the vehicle is started and when the button on the right-hand control is pressed directly. The system locks both rear wheels and the tilt system, preventing the vehicle from tilting sideways.

The system is disabled by pressing the button again: the light goes out. If the indicator light on the dashboard flashes, it indicates a problem with the parking brake system.

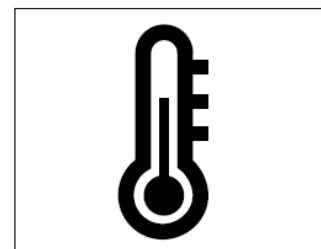

CONTROLS AND INSTRUMENTS

Turn signal indicator on

The turn signal light is green. It comes on and flashes to indicate whether the right or left turn signal is engaged. It goes off when the turn signals are turned off.

High beam indicator

The high beam indicator light is blue and turns on by operating the selector on the left switch.

Charging indicator

The charging indicator light is amber and remains solid when the charger is connected to the mains and the batteries are charging. It also lights up when the energy regeneration mode is activated.

OBD Diagnostic System Indicators for Error Detection

The OBD (On Board Diagnostic) system lights are amber in color and illuminate during communication between the vehicle and the external diagnostic device.

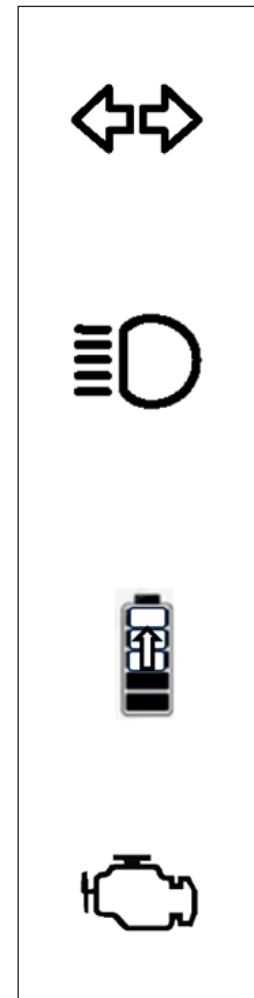

SPEEDOMETER

The speedometer displays the current speed. The value is displayed in kilometers per hour (km/h).

MENU SETTING BUTTONS

The SEL and SET buttons are used to:

- select the parameter to be displayed,
- reset the displayed value (km/trip),
- set and confirm new values (hour).

DIGITAL DISPLAY

The digital display provides all the information on the vehicle's status, specifically:

- presence of the batteries connected in the battery compartment,
- battery charge status,
- total mileage traveled,
- partial mileage traveled,
- kilometers that can be traveled with the remaining battery charge,
- time,
- alarms and related error codes.

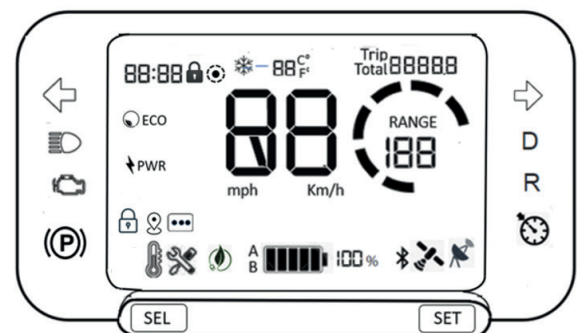

DISPLAY FUNCTIONS SELECTION

Odometer data display mode

When turned on, all the display lights will remain on for a few seconds.

Press **SEL** to change the parameter displayed on the display:

Total Total mileage traveled.
This parameter cannot be changed.

Trip Partial mileage traveled.
Press and hold **SET** to reset while displaying the parameter.

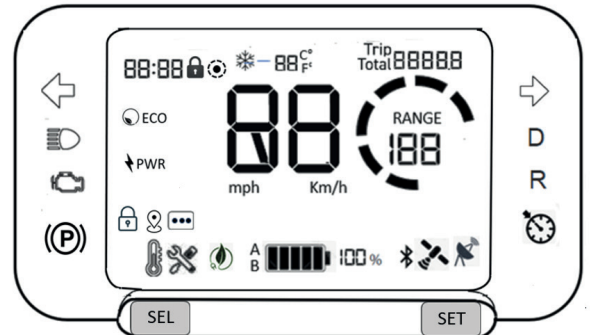

Vehicle autonomy

The vehicle range value indicated on the display is an estimate of the vehicle's remaining range under standard conditions.

Range

Distance that can be driven with the remaining battery charge. The value varies based on the battery charge status and the remaining charge.

When the batteries are fully charged, the vehicle uses power mode. When the batteries are low, ECO mode kicks in. In ECO mode, the vehicle has a range of approximately 15 km, and the speed is reduced to 30 km/h.

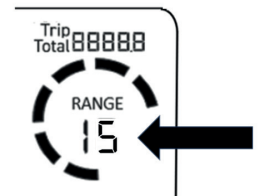

ATTENTION: reach a charging point as soon as possible in this condition.

Adjusting the clock function and date settings, Km

- Press and hold the **SEL** button to enter edit mode.
With **SEL**, you can only advance the data (example: 2024 -> 2025).
- After setting the desired year with **SEL**, press **SET** to move to the next setting, i.e., the date.
- Press the **SEL** button to switch between day and month, **SET** to move forward: here, you can first change the month (always pressing **SET** to move forward), then the day of the month.
Press **SET** to move forward to the next setting, i.e., the time.
- Press **SEL** to advance to the correct hours and then minutes.
- Press the **SET** button to move forward to the next setting, i.e., kilometers or miles ("km/h or mph");
- Press the **SEL** button to choose between km/h or mph, set the correct setting.
- Press the **SET** button to advance to the next temperature setting (°C or °F), press the **SEL** button to select between °C and °F.
- Press the **SET** button to exit the edit mode.

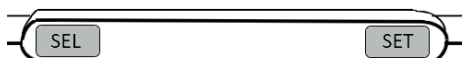

USE



PRE-DEPARTURE CHECKS

Before using the vehicle, it is always good practice to perform a few checks:

- Check the battery charge level,
- Check the operation of the headlight, taillight, turn signals, and license plate light,
- Check the operation of the front and rear brakes,
- Check the fluid levels in the front and rear brake reservoirs.
- Check the tire pressure,
- Check that the seat is closed and not raised.

To perform these checks correctly, refer to the instructions in this manual.

SAFE DRIVING

| | |
|---|--|
| WARNING | Before using the vehicle for the first time, we recommend that you test drive it in closed areas until you have acquired a good understanding of it. |
| WARNING | Always drive within the limits of your ability. |
|  | Driving while drunk, under the influence of drugs, or certain medications is very dangerous and is illegal. |
| WARNING | Before riding, always put on your helmet and fasten it properly. |
| WARNING | On rough roads, in rain, snow, or on slippery surfaces, it is necessary to reduce speed and increase the safety distance from other vehicles, driving with caution. |
|  | Do not apply full brakes on wet, unpaved, or slippery roads. |
| WARNING | After driving a long stretch of wet road without applying the brakes, the braking effect will initially be reduced. It is advisable to apply the brakes periodically in these conditions. |
|  | In case of rain, visibility decreases, reduce speed and drive with caution. |

START-UP OPERATIONS

Enabling and disabling the steering lock

To engage the steering lock, turn the handlebars to the left until they stop.

Press the key inward and turn it counterclockwise. (1); At the same time, slightly rotate the handlebars clockwise until the key clicks into the lock symbol.;  the steering lock is now engaged and the key can be removed.

To disengage the steering lock, insert the key into the Ignition switch (2) and turn it clockwise to the unlock symbol  the handlebars are free to rotate again.

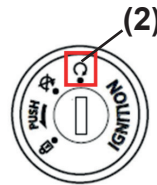
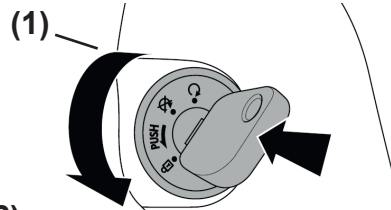
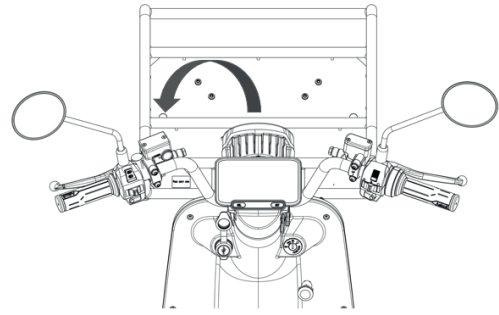

Motor enable

To start the engine, it must be enabled.

To enable the motor, insert the key into the ignition switch and turn it to the symbol  (2) then press the engine enable MODE button for 3 seconds, the warning light turns on (D) start button on the dashboard.

When the vehicle is started, the parking brake is locked.

To deactivate the parking brake, briefly press the button on the right-hand control on the handlebar. (3), (P)

Then select the driving mode by using the appropriate switch on the right control panel (4):

Position D = If the front gear is engaged, the vehicle's maximum speed is limited to 65 km/h.

Position  = the 4 emergency flashers are activated (5)

Position R = Reverse gear is engaged, the maximum speed in this mode is 4 km/h

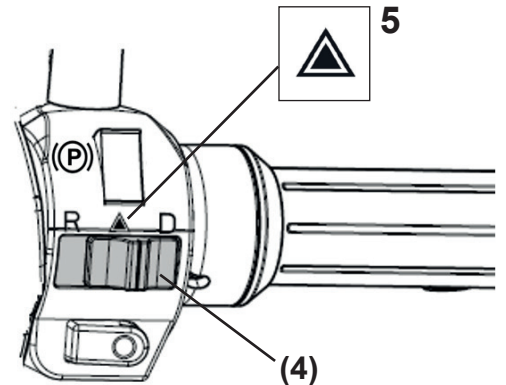
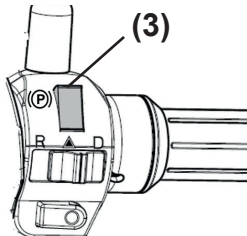
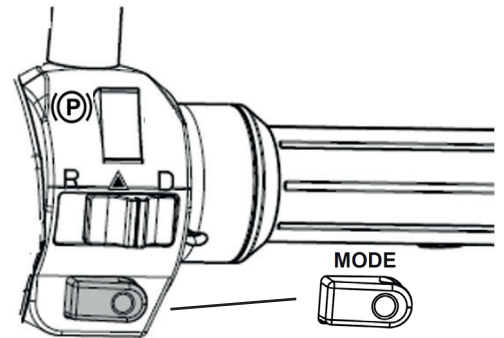

To disable the engine, press the MODE button again for 1 second and turn the key in the switch to the left corresponding to the symbol . The vehicle turns off.

The engine can also be disabled by simply turning the ignition key to the symbol  without necessarily pressing the MODE button.

USE

AUTONOMY

Autonomy: The vehicle's range is up to 120 km according to EU regulation 168/2013 (WLTP)

WARNING

Lithium-ion batteries experience a progressive decline in performance over time, which reduces their initial battery life.

WARNING

The indicated range data depends on the battery charge level, the number of charging cycles, and the operating temperature. Operating conditions can also affect range: slope and/or type of surface, ambient temperature, average speed, tire pressure, carried weight and user weight, and battery age.

USB SOCKET

The vehicle is equipped with a USB and USB-C port located on the upper left side of the vehicle's interior fascia, opposite the ignition switch. The USB port has an output voltage of 5V, 2A: it can charge smartphones and external devices.

WARNING

When the USB socket is not in use, it is recommended to keep the socket cover closed, especially in case of rain, to avoid water infiltration.

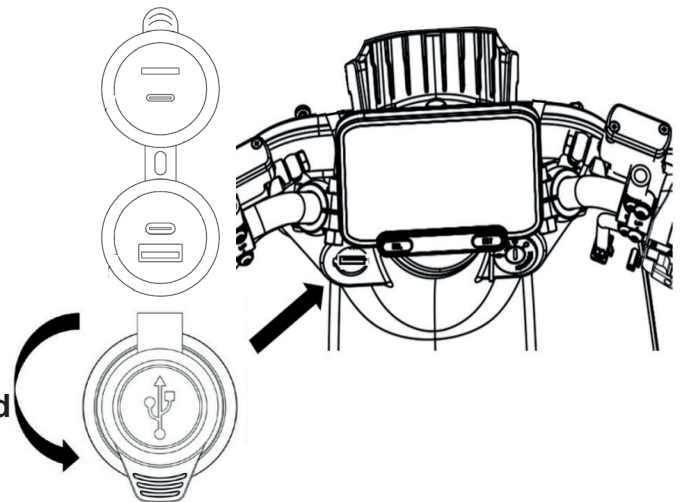

OBD DIAGNOSTICS

The eSpro 3 is equipped with the OBD (On Board Diagnostic) error detection system, in accordance with the provisions of the EURO 5 environmental regulation, which came into force on all new vehicles produced from January 1, 2021.

According to the requirements of the ISO 19689:2016 standard, relating to communication between the vehicle and external diagnostic equipment, the OBD connection for electronic error detection is located in the compartment under the seat.

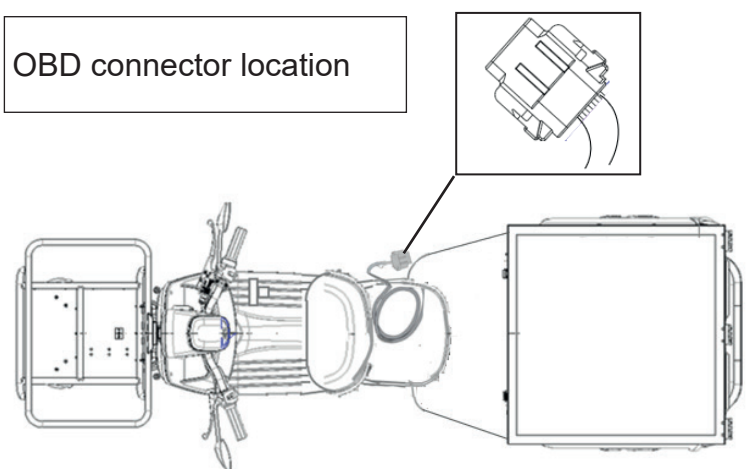

SADDLE

Saddle Opening

Turning the key to the left opens the vehicle seat.
Closing the seat automatically locks the lock.

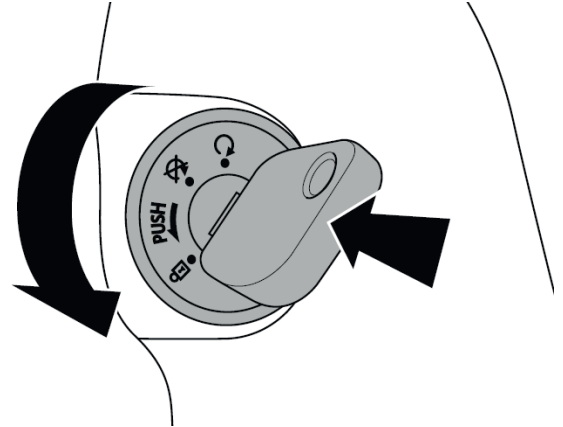

The OBD diagnostic cable (1) and the cable with Schuko socket for ON-BOARD battery charging (2) are stored in the compartment under the seat.

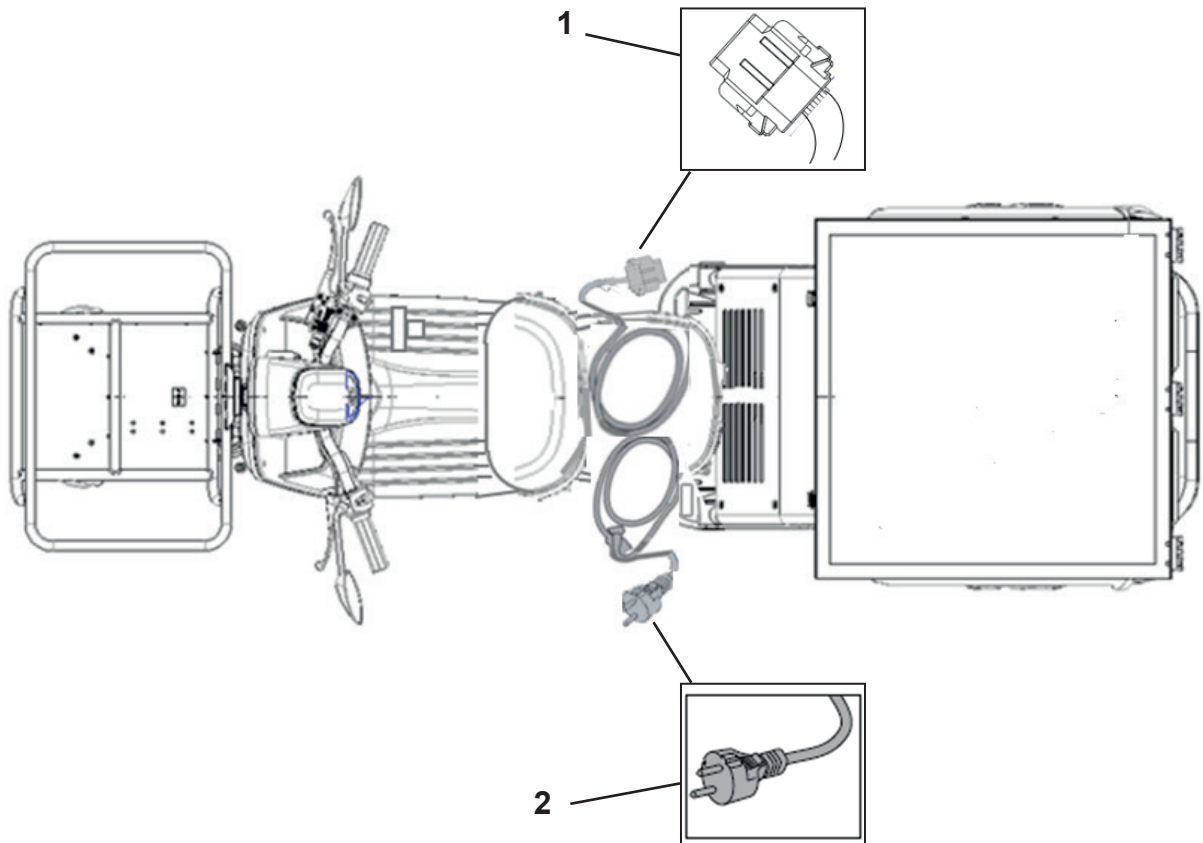

VEHICLE PARKING

The vehicle is equipped with an electric parking brake **ONLY**.

The parking brake activation button for the eSpro 3 vehicle is located on the right handlebar control, marked "P."

The parking control button locks both rear wheels and the tilt system, preventing the vehicle from tilting. The locking system is released by pressing the "P" button again.

The parking brake engages automatically each time the vehicle is turned off.

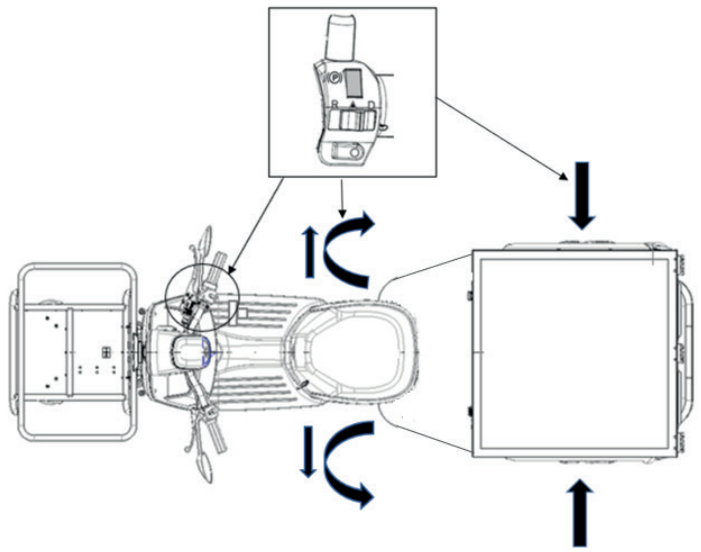

PARKING BRAKE OVERRIDE SYSTEM

It is possible to manually move the vehicle by bypassing the parking brake.

Start the vehicle by turning the ignition key to the **ON** position.

The icon will appear on the dashboard (P) which indicates that the parking brake is engaged.

Then press the parking brake release button (P) on the right-hand control for 3-4 seconds, and simultaneously turn the ignition key to the **OFF** position. The parking brake is bypassed, the vehicle can be moved manually.

If the vehicle is then restarted, the parking brake is activated automatically.

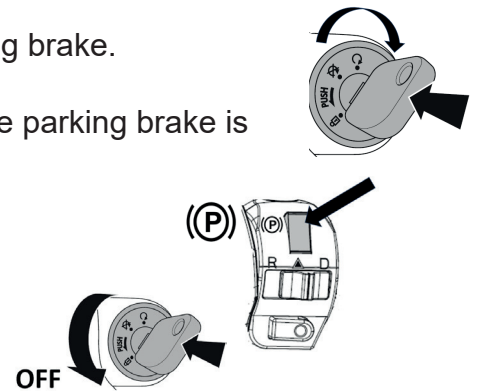

ATTENTION If the battery runs out while the vehicle is in motion and the vehicle stalls, the parking brake system will NOT remain locked, so the vehicle can be moved even when stationary.



If the vehicle stops due to flat battery, the parking brake will no longer be available. The vehicle must be parked safely, ensuring it cannot move inadvertently. To this end, and if this happens, it is necessary to place wheel blocks at the base of the wheels to prevent them from rolling.



If the batteries are completely discharged after prolonged parking, the parking brake remains activated and can only be released by recharging the batteries.

PARKING SENSORS

The vehicle is equipped with parking sensors located on the rear (**fig. 1**). The parking sensors are activated when the vehicle is running, and when reverse gear is engaged, an obstacle is detected from 1 meter away and acoustically indicated by a rapid, rhythmic beep as the obstacle approaches.

The sensors deactivate when reverse gear is disengaged.

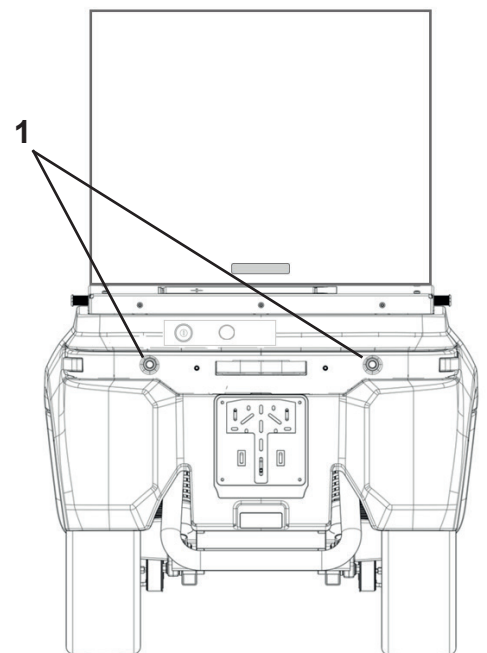

OPENING AND USE OF THE REAR TRUNK

The rear trunk is opened using the button located on the lower left side of the vehicle (fig.1): the key is used only in an emergency; the lock (fig.2) is located next to the trunk opening button.

If the trunk is not closed properly, the “trunk open” light (fig.8) on the dashboard comes on.

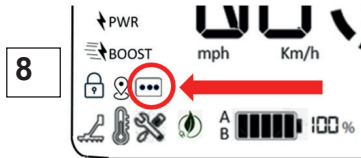

To open the rear trunk, take the external handle located at the bottom of the trunk (fig.3) and lift the lid (fig.4)

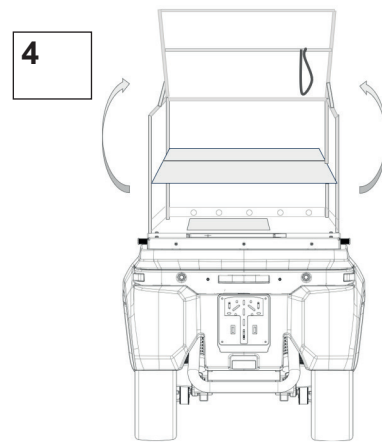
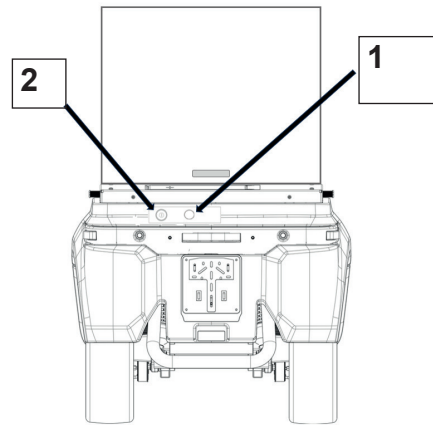
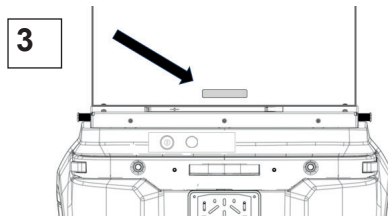

The rear trunk has multiple shelves that can be adjusted to suit your storage needs:
(fig.5) a solution with 2 full shelves,
(fig.6) a solution with the upper shelf folded halfway,
(fig.7) a solution with the upper shelf fully raised, to provide the full storage volume of the rear trunk.
(fig.8) To close the trunk, use the internal handle.

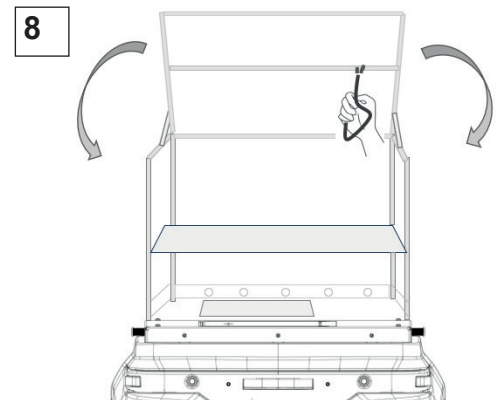
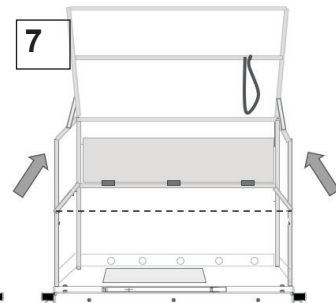
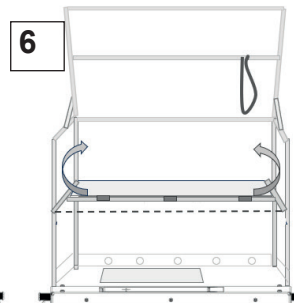
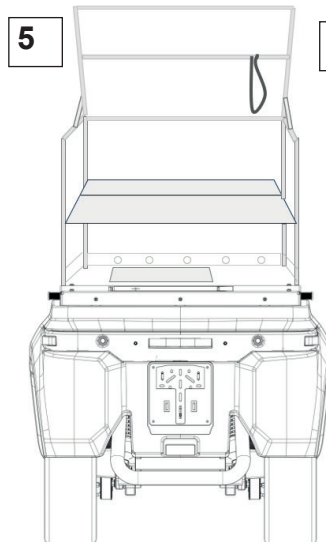

BATTERIES

The eSpro 3 vehicle is equipped with four removable lithium-ion batteries (model TC116) with a high capacity (1.7 kWh x 4), weighing 8 kg each.

The four batteries are housed in the compartment under the rear trunk, which is accessed through the dedicated door (fig.1).

The batteries must be recharged at an ambient temperature of between 0°C and +45°C: at low temperatures, a reduction in range may occur.

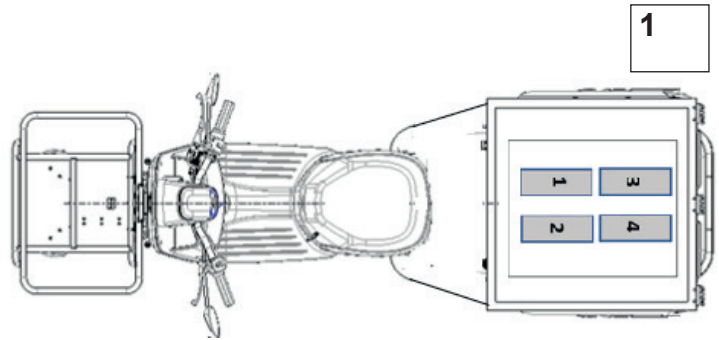

WARNING

If the batteries run out completely while the vehicle is in use, the system still allows the battery compartment to be opened for replacement. The vehicle can operate with a minimum of two batteries (one per engine), allowing it to be restarted and the parking brake to be released.

WARNING

The batteries charge and discharge in parallel evenly. If there is a charge mismatch between the batteries, the system works with those with a higher charge level. Consequently, the less charged ones are not used until the level of those in use drops to the point of intercepting them. This situation causes a temporary drop in the vehicle's efficiency (speed, acceleration).

WARNING

Be careful to always use batteries with the same charge level.

RECHARGE PERCENTAGE



Batteries should never be left with less than 20% charge remaining for more than 1 week. If the vehicle is not in use, it is recommended to never leave the batteries completely discharged, but to always charge them to 100% and disconnect them from the vehicle's wiring.



When the vehicle is not in use, if the batteries are left inside, the battery charger must be kept connected to the electrical outlet: the battery charger has the function of "maintenance" the batteries, maintaining a constant charge level. Check the battery charge level at least once a month.

If 100% charged batteries are stored outside the vehicle, check the charge maintenance level at least every 2 months.



Failure to comply with the above instructions will void the battery warranty.

BATTERIA E RICARICA



If the vehicle remains with the engine off for a long period in low temperatures (between 0°C and +10°C), the ON-Board battery charging times may be longer.



If the vehicle is not used for a long time, the batteries must be charged to 100% and disconnected from the vehicle wiring. Check the battery charge level at least once every two months.



Batteries must not be used in ambient temperatures outside the range of -10°C to +45°C.



The batteries must not be subjected to impacts and must not show signs of external damage of any kind.



Batteries, both during charging and storage, should not be exposed to sources of heat/cold, humidity, dust, or weather.



The warranty covers battery malfunctions resulting from manufacturing defects, inability to charge and discharge.



The warranty does not cover battery performance degradation due to normal use and aging.



The manufacturer reserves the right to evaluate the validity of the warranty based on the analysis of the batteries.



Never disconnect the electrical system cables with the engine running to avoid damaging the batteries.



Disassembling and/or tampering with the batteries will void the warranty.



Out of respect for the environment, at the end of their life cycle, batteries must be disposed of, collected, and disposed of in accordance with applicable laws.



Do not use this battery for purposes other than those specified. Use for purposes other than those intended may cause a short circuit within the battery, which could cause a fire.



It is not recommended to completely discharge the batteries, as this will cause them to wear out prematurely.



Fire Hazard

- Do not disassemble or destroy the battery.
- An accident resulting in serious mechanical damage to the battery may cause a short circuit within the battery, which could damage it or catch fire.
- If a fire starts, and if the fire could spread to nearby objects, notify the fire department immediately.



Failure to follow the recommendations above will void the battery warranty.

Disposal of used batteries

At the end of its useful life, a battery pack containing lithium batteries must be disposed of in accordance with current regulations and cannot be thrown away as ordinary waste.

The European Directive for this type of waste establishes that the states adhering to this convention undertake to adopt “appropriate measures” to ensure that spent batteries are collected separately for the purpose of their possible recovery or disposal.

In any case, for more up-to-date information on this matter, users are invited to contact the municipal office responsible for this matter.



BATTERY AND CHARGING

TLPower 1200BG6020L BATTERY CHARGER

This charger is intended for use exclusively with the Askoll eSpro 3 vehicle.

The charger is activated only when connected to the mains power supply using the appropriate power cable located under the vehicle's seat.

HOW THE BATTERY CHARGER WORKS

When the power cable is connected to the electrical outlet, the top fan of the battery charger starts to operate, keeping the internal temperature low during charging.

The fan turns off when the power cable is disconnected from the electrical outlet.

The battery charger in the vehicle is located under the battery compartment: in this area, hot air is expelled by channeling it towards the special vents located near the license plate holder.



Risk of electric shock

- This appliance is equipped with a cable with a Schuko plug.
- Connect the appliance to a power supply protected by a residual current circuit breaker with a sensitivity not exceeding 30 mA.
- The appliance's electrical connection must comply with the data shown on the appliance's electrical rating label.
- Do not use extension cords. If the power cord is insufficient, contact a qualified electrician or installer.
- Do not cut and/or repair the power wire.

BATTERY CHARGING

The battery charge level is visible in the center of the vehicle's digital display. The A icon on the display indicates the charge level of the four batteries housed in the compartment under the rear bed.

The batteries can be charged in two ways:



- **CHARGING WITH ONBOARD BATTERY**
- **CHARGING WITH OFFBOARD BATTERY**

CHARGING WITH ON-BOARD BATTERY

To charge with the battery on board, proceed as follows:

Disable the vehicle system by turning the ignition key to OFF.

Open the rear trunk using the appropriate button located on the lower left side of the vehicle (fig.1)

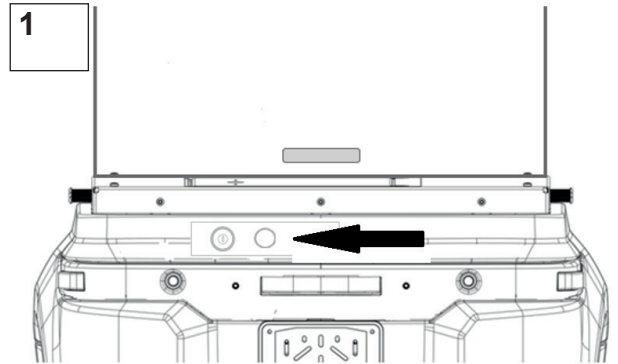

Lift the rear trunk (fig.2), and open the door located on the battery compartment floor (fig.3) using the appropriate key (the key is the same one used to start the vehicle)

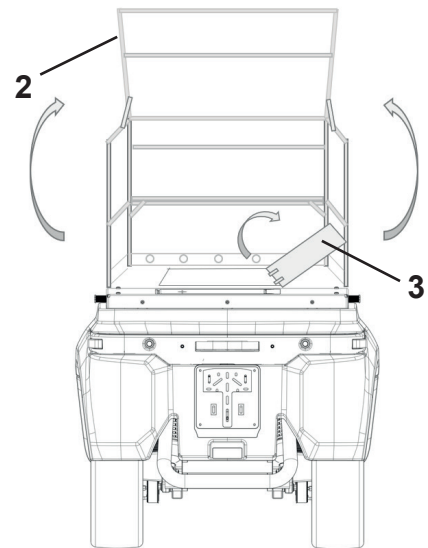

Check that the batteries are correctly inserted into the compartments according to the orientation of the arrows (fig.4) on the top of the batteries (the arrow indicates the insertion side towards the wiring connector).

To charge the batteries, connect the cable (fig.5) located under the seat compartment to the electrical mains. During charging, the relevant light on the dashboard will light up.

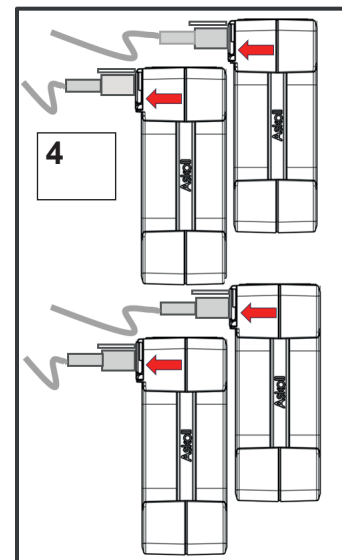
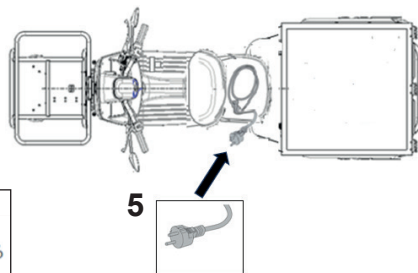

BATTERY AND CHARGING



To charge the batteries ON-BOARD, check that all the batteries are connected to their connectors, then proceed to connect the charging socket under the saddle to the electrical network.

ATTENTION

Charging times (under standard conditions with ambient temperature +10°C/+30°C) performed in ON-Board mode, with completely flat batteries can reach up to 8 hours.

ATTENTION

The operating temperature of the batteries (during vehicle use) can reach up to approximately 60°C. If you attempt to charge immediately after using the vehicle, the system may put the charging system on standby, illuminating the high temperature warning light (1) on the dashboard.

Charging will start when the battery temperature drops below the safety limit of 45°C.

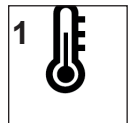

ATTENTION

If one or more batteries fail during charging, the system proceeds to charge the remaining batteries. The failed batteries remain in standby mode. Charging will resume once the remaining batteries are fully charged. This may extend charging times.

ATTENTION

If on-board charging occurs at low ambient temperatures, such as 0°C to 10°C, or at high ambient temperatures above 35°C to 45°C, charging times may be extended.

If ambient temperatures are below 0°C or above 45°C, the batteries will not charge.

CHARGING WITH OFFBOARD CHARGER

It's possible to charge the batteries externally to the vehicle. This can be done using various solutions, depending on your company's needs.

External battery charging with ASKOLL Smart Battery Charger and charging splitter.

Disconnect the batteries from the vehicle's connectors (fig. 1), remove the batteries from the compartment under the rear trunk, using the handle (fig. 2) to lift them.

Once the battery is removed, support it with both hands.

Use the ASKOLL Smart battery charger (fig. 3), connecting it to the charging splitter (fig. 4), and then plugging the charger into the electrical outlet.

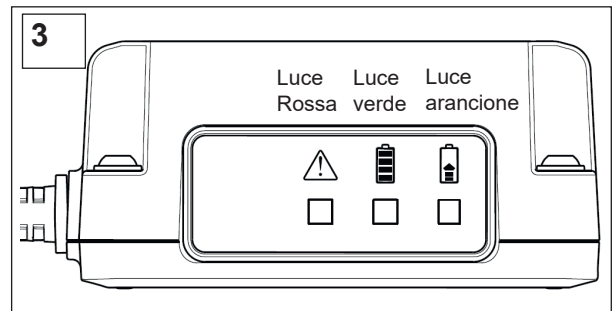
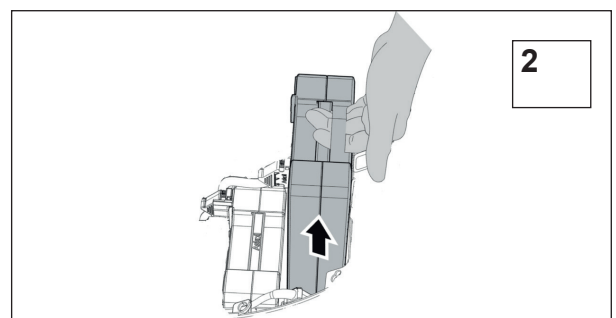
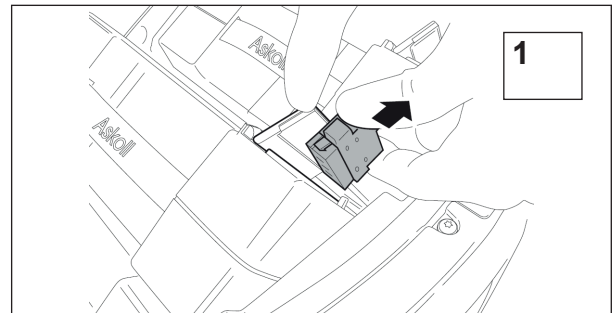

SMART BATTERY CHARGER

This charger must be purchased separately from the vehicle and is intended for use exclusively with Askoll vehicles.

The charger is activated only when connected to the electrical net with the appropriate power cable.

Charger functions

- **LEDs off:** Charger not connected to the power supply.
- **GREEN LED on:** Battery connected and charging.
- **ORANGE LED flashing:** Battery connected but with an error, charging not working. If the problem persists, take the battery to a service center.
- **ORANGE LED on:** Charging in progress.

During the charging phase, the charging progress is indicated by the GREEN LED through quick flashes corresponding to this coding.:

1 GREEN LED flash: battery very low.

2 GREEN LED flashes: battery medium charge.

3 GREEN LED flashes: battery almost fully charged.

NOTE: If two batteries are connected together via the charger splitter accessory, the indication refers to the more discharged battery.

- **Flashing RED LED:** indicates a high charger temperature; charging may continue at a reduced or very reduced rate, with longer charging times. Place the charger in a cool place and never on top of a battery. Make sure the ventilation grilles are clear and that the fans are working properly; otherwise, contact a service center.
- **RED LED on:** Error detected, charging not possible. Try disconnecting and reconnecting the battery and the power supply. If the problem persists, contact a service center.

BATTERY AND CHARGING

Turning on the Smart Charger's fans

The charger's fans turn on under the following conditions:

- Within the first 2 seconds after connecting the charger to the power supply.
- When the charger is charging.
- When the charger's internal temperature is above 50°C.

Charge splitter accessory

The charging splitter accessory (fig. 4) is supplied and can only be used with the **ASKOLL SMART battery charger**, and in "**OFFBOARD**" mode.

To use it, proceed as follows:

Connect the charging splitter to the Smart battery charger.

Then connect the splitter's connectors directly to the battery sockets.

Connect the Smart battery charger to the mains power supply. It will then be possible to charge two batteries simultaneously.

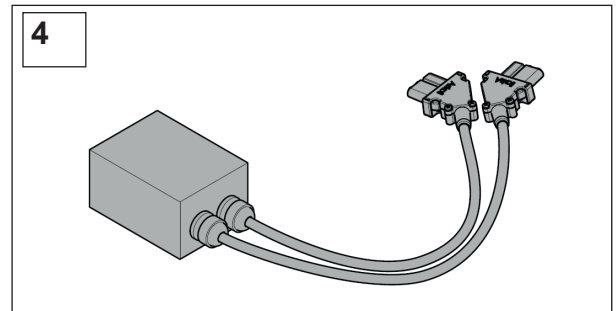

OFFBOARD BATTERY CHARGING VIA THE BATTERY CHARGING CABIN

For fleets of vehicles, it is possible to charge the batteries externally, using a special 24-slot battery charging cabinet.

This allows the batteries of up to 6 vehicles to be charged simultaneously, making the operation quick and convenient.

Proceed by disconnecting the batteries from the connectors (**fig. 1**), remove the batteries from the compartment under the rear trunk, using the handle (**fig. 2**) to lift them.

Once the battery is removed, support it with both hands.

Place the batteries in the slots on the charging cabinet.

Connect the batteries to the charging cables inside the cabinet slots and turn on the power switch on the cabinet.

(For this operation, consult the IP54 battery charging cabinet manual.)

Once charging is complete, place the batteries back into their compartment, holding them by the handle, and reconnect the connectors to the batteries (**see instructions on page 23 regarding positioning the batteries**

inside the compartment). Make sure to insert the connector into the battery socket as far as it will go (**fig.3**), and check that it is securely attached to the door on the battery, which also acts as a connector safety lock (**fig.4**).

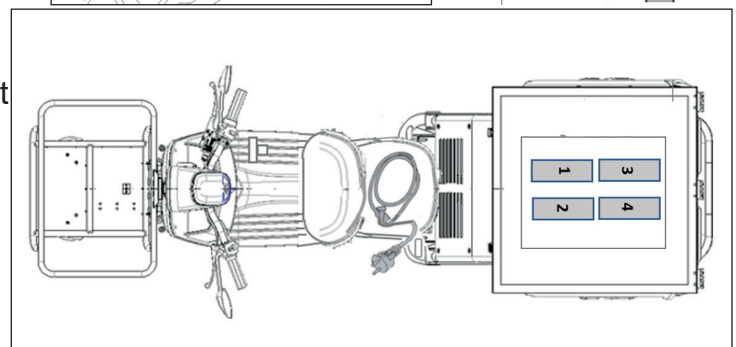
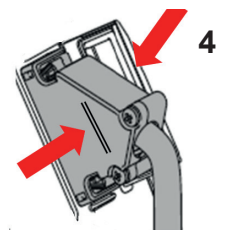
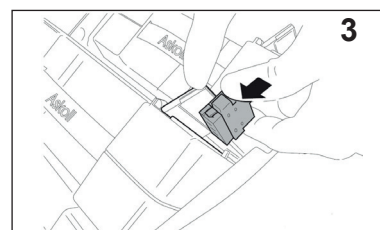
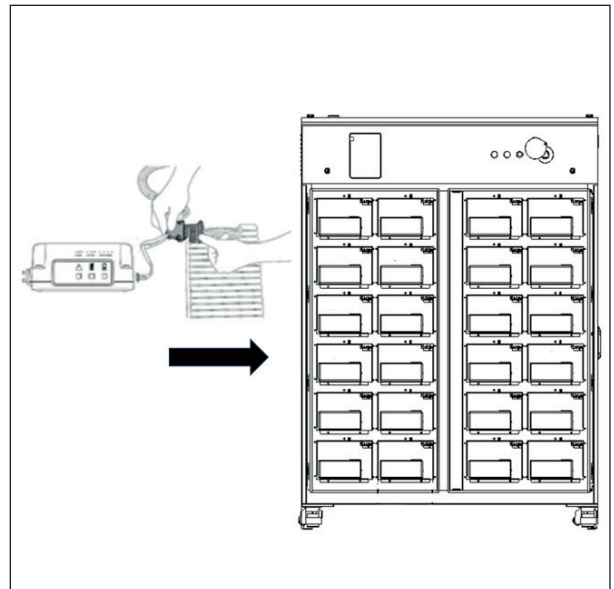
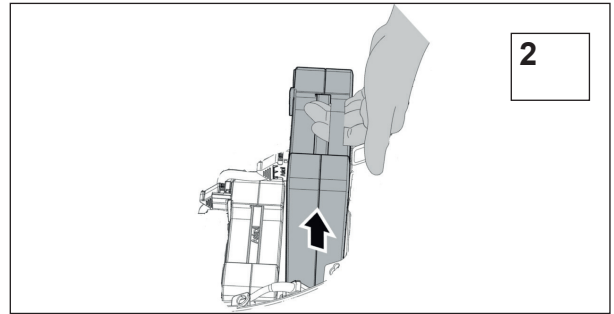
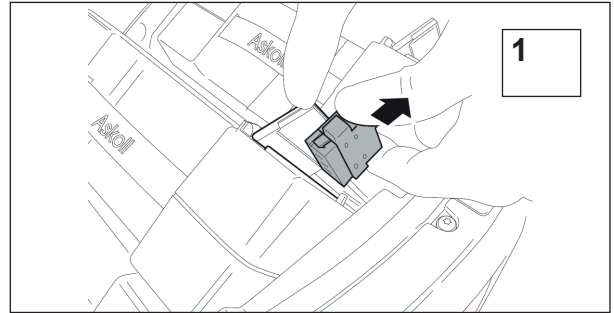

ADJUSTMENTS AND PERIODIC MAINTENANCE

ADJUSTMENTS

REARVIEW MIRRORS

Mounted on the left and right sides of the handlebars are the two rearview mirrors. They can be adjusted by manually rotating the stem until the mirror reaches the desired position.

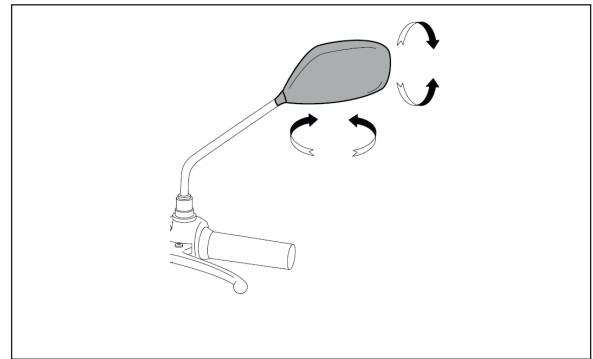

FRONT HEADLIGHT

The height of the headlight's light beam can be adjusted by turning the adjustment screw located under the headlight itself, using the TORX T20 wrench.

Turning the screw 1/2 turn clockwise will point the light beam downward, while turning it counterclockwise will point the light beam upward.

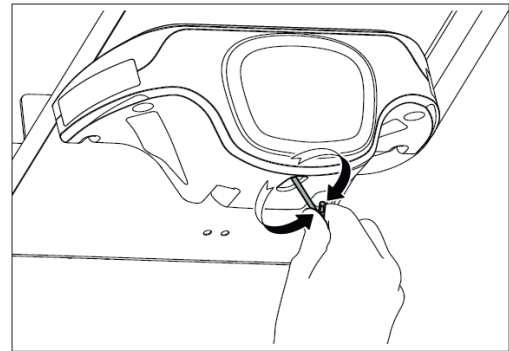

FRONT DISC BRAKE

Disc and pad wear is automatically compensated for, so it has no impact on brake function and requires no adjustment.

If excessive travel is detected and the lever gets too close to the grip when applying the brake, it could indicate air in the circuit or irregular braking.

Effective braking should begin after approximately 1/3 of the brake lever travel.

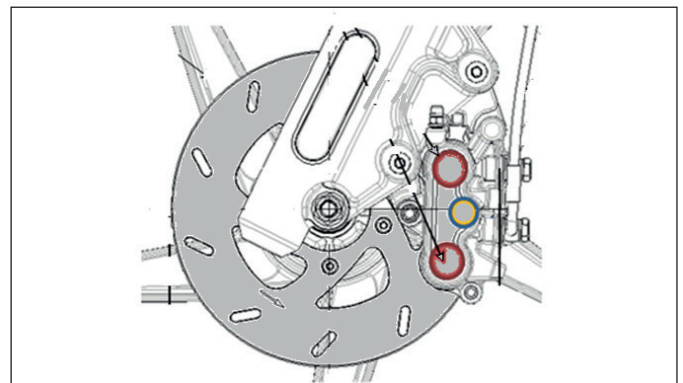

REAR DISC BRAKE

Disc and pad wear is automatically compensated for, so it has no impact on brake function and requires no adjustment. If excessive travel is detected and the lever gets too close to the grip when applying the brake, it could indicate the presence of air in the circuit or irregular braking performance. Effective braking should begin after approximately 1/3 of the brake lever travel.

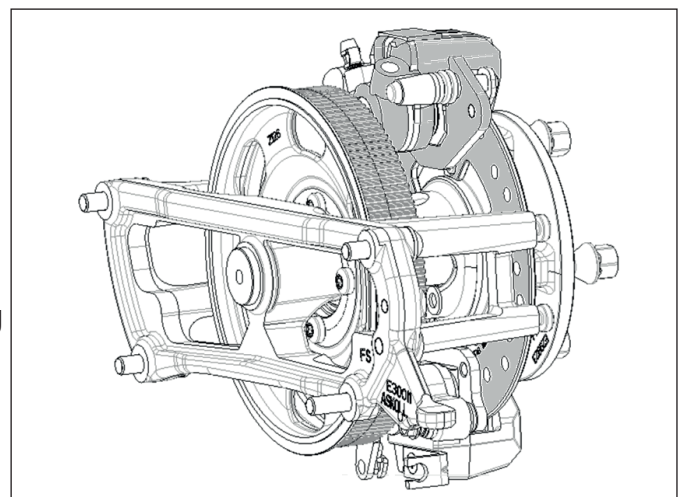

ADJUSTMENTS AND PERIODIC MAINTENANCE

REAR BRAKE WITH COMBINATED FUNCTION

Combined braking can be performed in 2 ways, via the left brake lever on the handlebar, or by operating the pedal on the right side of the footrest: the braking system acts on the brake calipers of the rear wheels and on the front brake caliper.

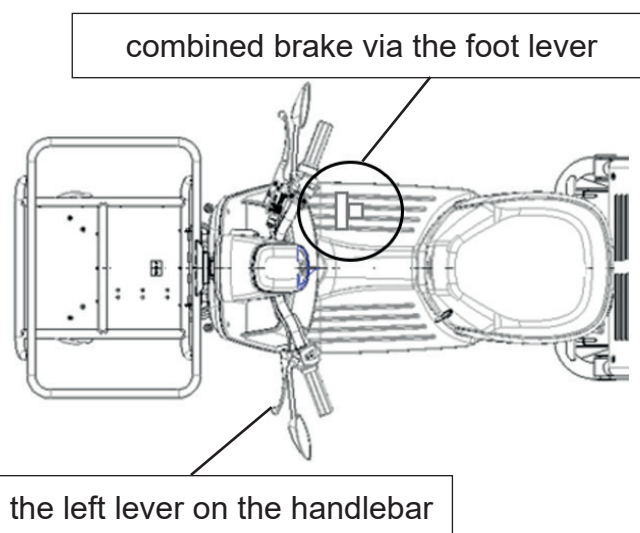

WARNING

If the brakes aren't working properly, check the brake pads for wear. If they're very thin, they should be replaced at an authorized service center.

WARNING

After replacing the pads, operate the brake pedal several times to reposition the pads correctly.

ROUTINE MAINTENANCE PROCEDURES

TIRES

The vehicle is equipped with tubeless tires. Check the tire pressure regularly and adjust if necessary before setting off.

Front tire pressure: 2 bar.

Rear tire pressure: 2 bar.

The tires are equipped with wear indicators and should be replaced as soon as these indicators are visible on the tread.

Also check the sidewalls of the tires for cuts or uneven wear. If this occurs, contact an authorized workshop for replacement.

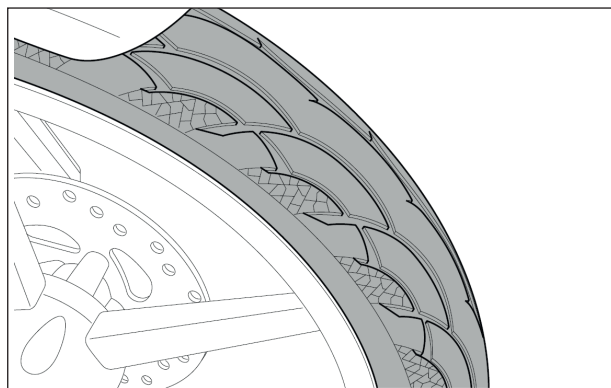

WARNING

Always check tire pressure when cold. Incorrect pressure causes abnormal tire wear and makes driving dangerous.

WARNING

The tire must be replaced when the tread reaches the wear limit established by current regulations.

ADJUSTMENTS AND PERIODIC MAINTENANCE

CHECKING THE BRAKE FLUID LEVEL

The front and rear brake fluid reservoirs are equipped with inspection windows to check the fluid level.

To check the fluid level in the reservoir, you can look through the inspection window through the slot located on the front right side of the handlebar cover (front brake); for the combined brake, it is located on the left side of the handlebar. If the brake fluid level is low or insufficient, NEVER top up the reservoir.

Instead, check the brake pads and discs for wear and check for any brake circuit leaks..

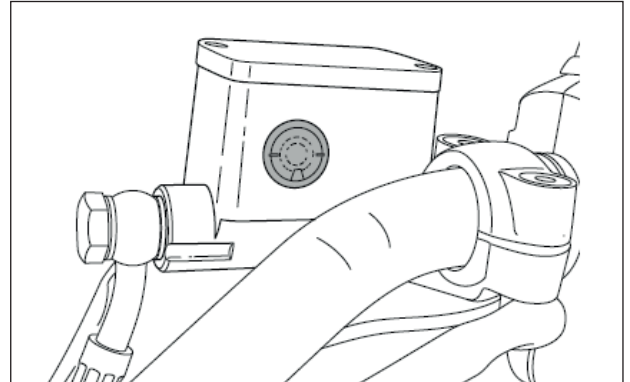

WARNING

The brake fluid is hygroscopic, meaning it absorbs moisture from the surrounding air. If the moisture content in the fluid exceeds a certain level, braking will be inefficient.

WARNING

It's recommended to have the fluid changed every two years. Never use brake fluid from opened or partially used containers.

WARNING

Make sure only DOT4 rated brake fluid is used.

WARNING

Brake fluid is highly corrosive. Avoid contact with skin or painted surfaces. In case of contact with skin, rinse thoroughly with water.

ADJUSTMENTS AND PERIODIC MAINTENANCE

eSpro 3 HEADLIGHT

The **eSpro 3** model features a front headlight with an LED bulb and does not require replacement. If the bulb is worn out, the entire headlight must be replaced.

For replacement, contact an authorized service center.

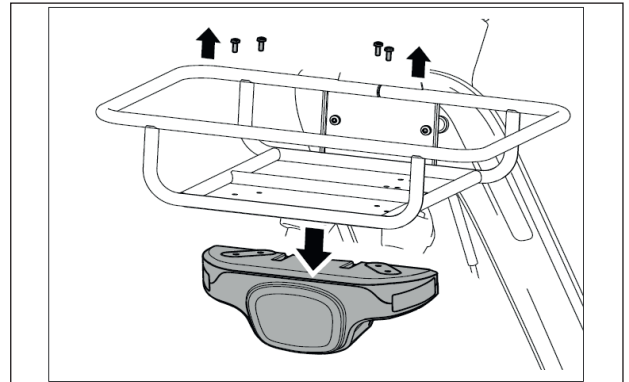

eSpro 3 REAR LIGHTS AND LIGHT INDICATOR

The rear light cluster, the front and rear turn signals, and the license plate light are equipped with LED lights and are integrated into the vehicle structure.

To replace them, contact an authorized service center.

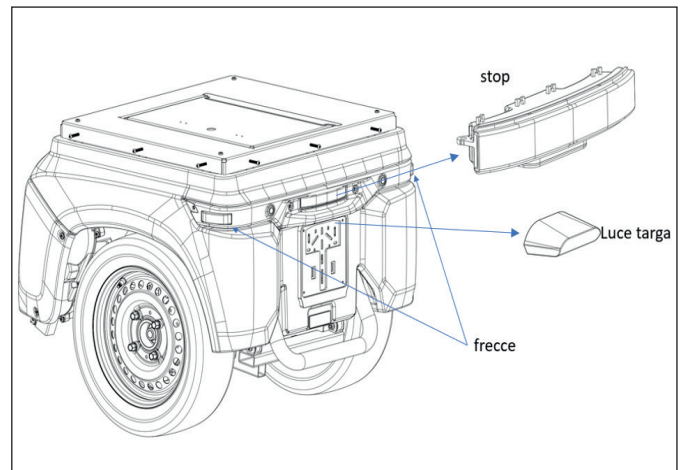

ADJUSTMENTS AND PERIODIC MAINTENANCE

SUMMARY TABLE OF ROUTINE MAINTENANCE PROCEDURES

C: Check; R: Adjust; L: Lubricate; S: Replace

| YEAR | 1° CHECK | 1 Year | 2 Years | 3 Years | 4 Years | 5 Years | 6 Years | 7 Years | 8 Years | 9 Years |
|--|-------------|-----------|------------|------------|------------|------------|------------|------------|------------|------------|
| Km x 1.000 | 2 | 6 | 12 | 18 | 24 | 30 | 36 | 42 | 48 | 54 |
| Front/rear brake fluid (replace every 2 years) | | C | S | C | S | C | S | C | S | C |
| Brake pad wear front/rear | C | C/S | C/S | C/S | C/S | C/S | C/S | C/S | C/S | C/S |
| Check the brake disc front/rear | C | C/S | C/S | C/S | C/S | C/S | C/S | C/S | C/S | C/S |
| First stage Poly-V drive belts (1 x motor) | C | C | S | C/S | S | C/S | S | C/S | S | C/S |
| Second stage toothed drive belts (1 x motor) | C | C | S | C/S | S | C/S | S | C/S | S | C/S |
| Check the rear pulleys, primary internal, external, and secondary to the rear wheels | C | C | C | C | S | C | C | C | S | C |
| Rear box nuts, bolts and fasteners/bolts (free from slack) | C | C | C | C | C | C | C | C | C | C |
| Steering bearings | C | | C | | C | | C | | C | |
| Front tire/rear tires | C | C/S | C/S | C/S | C/S | C/S | C/S | C/S | C/S | C/S |
| Front fork/rear shock absorbers | C | C | C | C | C | C | C | C | C | C |
| Checking electrical devices and electrical system operation | C | C | C | C | C | C | C | C | C | C |
| Check rear parking sensor devices | C | C | C | C | C | C | C | C | C | C |
| Parking brake sheaths and tilt brake sheaths | C | C | C | C | S | C | C | C | S | C |
| Electric parking brake | C/R | C/R | C/R | C/R | C/R | C/R | C/R | C/R | C/R | C/R |
| Combined foot brake | C | C | C | C | C | C | C | C | C | C |
| Tilting joint system | C | C | C | C | C | C | C | C | C | C |

NOTE: (*) ALWAYS perform the first vehicle inspection at **2,000 km**. Service interval: services must be performed within the indicated mileage interval. If the mileage has not been reached, it is recommended that the vehicle be **serviced annually**.

ADJUSTMENTS AND PERIODIC MAINTENANCE

VEHICLE CLEANING

To prevent oxidation, wash the vehicle whenever it is used in particular weather or road conditions, such as roads covered with salt or de-icing products in the winter, air pollution such as in cities, industrial areas, areas with high salinity or humidity, or atmospheric pollution such as near the sea. Do not allow dirt, industrial dust, dead insects, bird droppings, etc., to remain on the bodywork for long periods of time.

Use a low-pressure water jet to loosen any dirt on the painted surfaces, then remove it with a soft bodywork sponge soaked in plenty of water and shampoo, then rinse and dry with a chamois.

Avoid washing the scooter directly in the sun, especially in summer, to prevent the bodywork from heating up and drying the shampoo immediately before rinsing, which could damage the paintwork.



Do not use high-pressure water jets for washing, to avoid damaging delicate vehicle components.



When washing, never direct the water jet directly at delicate components such as electrical wiring and their connections.



Never use rags soaked in petrol, alcohol or potentially corrosive liquids to wash painted surfaces, plastics or the seat cover to avoid loss of shine and mechanical characteristics of the materials, or damage to them.



The scooter must be washed in areas equipped for the collection and purification of the liquids used.

VEHICLE INACTIVITY

When preparing for a long period of inactivity, it is advisable to:

- Recharge the batteries to 100%
- Perform a general cleaning of the vehicle,
- Store the vehicle indoors,
- Cover the vehicle with a tarp.

ERROR CODES

ECU ERROR CODES

| | |
|--|-------------|
| <p>Dashboard/ECU communication error: Communication problems are detected between the vehicle's intelligent units, specifically between the dashboard and the ECU. It is recommended to take the vehicle to an authorized workshop.</p> | E001 |
| <p>Charging plug sensor error: If there are any problems with the charging socket, check that the charging cable is plugged in. The charging light is flashing rapidly.</p> | E002 |
| <p>Throttle failure error: If a malfunction of the accelerator is detected, we recommend performing a preliminary cleaning of the connector. If the problem persists, replace the accelerator at an authorized center.</p> | E003 |
| <p>Error due to front headlight failure: If a malfunction of the front headlight is detected, it is advisable to take the vehicle to an authorized center.</p> | E004 |
| <p>Error due to faulty front left turn signal: If a malfunction of the front left direction indicator is detected, we recommend taking the vehicle to an authorised centre.</p> | E005 |
| <p>Error due to faulty front right direction indicator: If a malfunction is detected in the front right turn signal, we recommend taking the vehicle to an authorized service center.</p> | E006 |
| <p>Error due to failure of the rear left direction indicator: If a malfunction is detected in the rear left turn signal, we recommend taking the vehicle to an authorized service center.</p> | E007 |
| <p>Error due to failure of the rear right direction indicator: If a malfunction is detected in the rear right turn signal, we recommend taking the vehicle to an authorized service center.</p> | E008 |

ECU ERROR CODES

| | |
|---|--------------------|
| <p>Rear brake light failure error: If a malfunction is detected with the rear brake light, it is advisable to take the vehicle to an authorized center.</p> | <p>E009</p> |
| <p>Rear light failure error: A malfunction is detected in the rear headlight or license plate light. It is recommended to take the vehicle to an authorized workshop.</p> | <p>E010</p> |
| <p>12V horn failure error: If a horn malfunction is detected, it is advisable to take the vehicle to an authorised workshop.</p> | <p>E011</p> |
| <p>12V dashboard fault error: If a malfunction is detected in the dashboard, we recommend taking the vehicle to an authorized service center.</p> | <p>E013</p> |
| <p>Error due to 12V failure in the handlebar controls: If a malfunction is detected in the handlebar controls, we recommend taking the vehicle to an authorized center.</p> | <p>E014</p> |
| <p>Parking brake button failure error: If a malfunction of the parking brake actuation button is detected, we recommend taking the vehicle to an authorized center.</p> | <p>E015</p> |
| <p>AUX output failure error: a malfunction is detected in the AUX output, the USB socket has functional problems, we recommend taking the vehicle to an authorized center.</p> | <p>E016</p> |
| <p>Tamper-evident system failure error: A malfunction is detected in the anti-tamper system; the wrong inverter or ECU has been installed for this vehicle. It is recommended to take the vehicle to an authorized service center.</p> | <p>E017</p> |

ERROR CODES

ECU ERROR CODES

| | |
|--|-------------|
| <p>Immobilizer active: Vehicle immobilizer is detected active, the vehicle has been remotely locked.</p> | E018 |
| <p>Steering wheel lock system blocked: The steering lock is detected as engaged, which may occur if the vehicle is activated remotely. It is recommended to take the vehicle to an authorized service center.</p> | E019 |
| RIGHT POWERTRAIN ERROR CODES | |
| <p>Right motor Hall probe failure: a fault is detected in the Hall sensors of the right engine, it is advisable to take the vehicle to an authorized center.</p> | E020 |
| <p>Right motore overtemperature detected: Overtemperature of the right engine is detected, it is advisable to stop the vehicle, if the problem persists take the vehicle to an authorised centre.</p> | E021 |
| <p>Right motor thermal sensor fault: If a fault is detected with the right engine temperature sensor, we recommend taking the vehicle to an authorized service center.</p> | E022 |
| <p>Right inverter thermal sensor fault: If a fault is detected with the right inverter's thermal sensor, we recommend taking the vehicle to an authorized service center.</p> | E023 |
| <p>Inverter right motor control failure: If a fault is detected in the inverter's right motor control, we recommend taking the vehicle to an authorized service center.</p> | E024 |

RIGHT POWERTRAIN ERROR CODES

| | |
|---|--------------------|
| <p>Right Inverter control fault: If a fault is detected in the inverter's right control, it is recommended to take the vehicle to an authorised centre</p> | <p>E025</p> |
| <p>Right inverter overtemperature detected: If an overtemperature is detected on the right inverter, it is recommended to stop the vehicle. If the problem persists, take the vehicle to an authorized service center.</p> | <p>E026</p> |
| <p>Right inverter communication error detected: If the Dx inverter communication error is detected, we recommend taking the vehicle to an authorized center.</p> | <p>E027</p> |

LEFT POWERTRAIN ERROR CODES

| | |
|---|--------------------|
| <p>Left motor Hall sensor fault: If a Left motor Hall Sensor Fault is detected, it is recommended to take the vehicle to an authorised centre.</p> | <p>E030</p> |
| <p>Left motor Overtemperature Detected: If an overtemperature in the left motor is detected, it is recommended to stop the vehicle. If the problem persists, take the vehicle to an authorized service center.</p> | <p>E031</p> |
| <p>Left motor Thermal Sensor Fault Detected: If a fault is detected with the left motor temperature sensor, we recommend taking the vehicle to an authorized service center.</p> | <p>E032</p> |
| <p>Left inverter thermal sensor fault detected: If a fault is detected with the thermal sensor of the left inverter, we recommend taking the vehicle to an authorized service center.</p> | <p>E033</p> |

ERROR CODES

LEFT POWERTRAIN ERROR CODES

| | |
|---|-------------|
| Left inverter motor control fault detected: If a fault is detected in the left inverter motor control, we recommend taking the vehicle to an authorized service center. | E034 |
| Left inverter control fault detected: If a fault is detected in the left inverter control, we recommend taking the vehicle to an authorized service center. | E035 |
| Left inverter overtemperature detected: If an overtemperature is detected on the left inverter, it is recommended to turn off the vehicle. If the problem persists, take the vehicle to an authorized service center. | E036 |
| Left inverter communication error detected: If a communication error is detected with the left inverter, we recommend taking the vehicle to an authorized service center. | E037 |

BATTERY ERROR CODES

| | |
|---|-------------|
| Battery Short Circuit Detected: If a short circuit is detected in the battery, we recommend having the condition of the batteries checked by an authorized center. | E050 |
| Battery BSM Temperature Sensor Fault Detected: If a BSM Battery Temperature Sensor Fault is detected, it is recommended to take the vehicle to an authorised service centre. | E051 |
| Excessive/Insufficient Battery Temperature Detected: If an excessive/insufficient battery temperature is detected, it is recommended to disconnect the batteries, wait a few minutes, and then reconnect them to the vehicle. If the excessive/insufficient temperature signal persists, it is recommended to take the vehicle to an authorized service center. | E052 |

EXPANDER ERROR CODES

| | |
|--|-------------|
| Parking brake failure: If a parking brake fault is detected, it is recommended to take the vehicle to an authorised centre | E090 |
| Internal I/O expander failure: If an internal fault is detected in the I/O expander, it is recommended to take the vehicle to an authorized center. | E091 |
| I/O expander fan power failure detected: A power supply fault has been detected in the cooling fan of the I/O expander, located behind the license plate. It is recommended that the vehicle be taken to an authorized service center. | E092 |
| Parking sensor power supply fault detected Exander I/O: If a Parking Sensor Power Fault I/O Expander is detected, it is recommended to take the vehicle to an authorized service center. | E093 |
| Rear trunk opening system power supply fault detected: If a power failure is detected in the rear trunk opening system, it is recommended to take the vehicle to an authorized center. | E094 |
| I/O Expander Communication Error Detected: If an I/O expander communication error is detected, we recommend taking the vehicle to an authorized service center. | E095 |

TECHNICAL DATA

VEHICLE DIMENSIONS eSpro 3

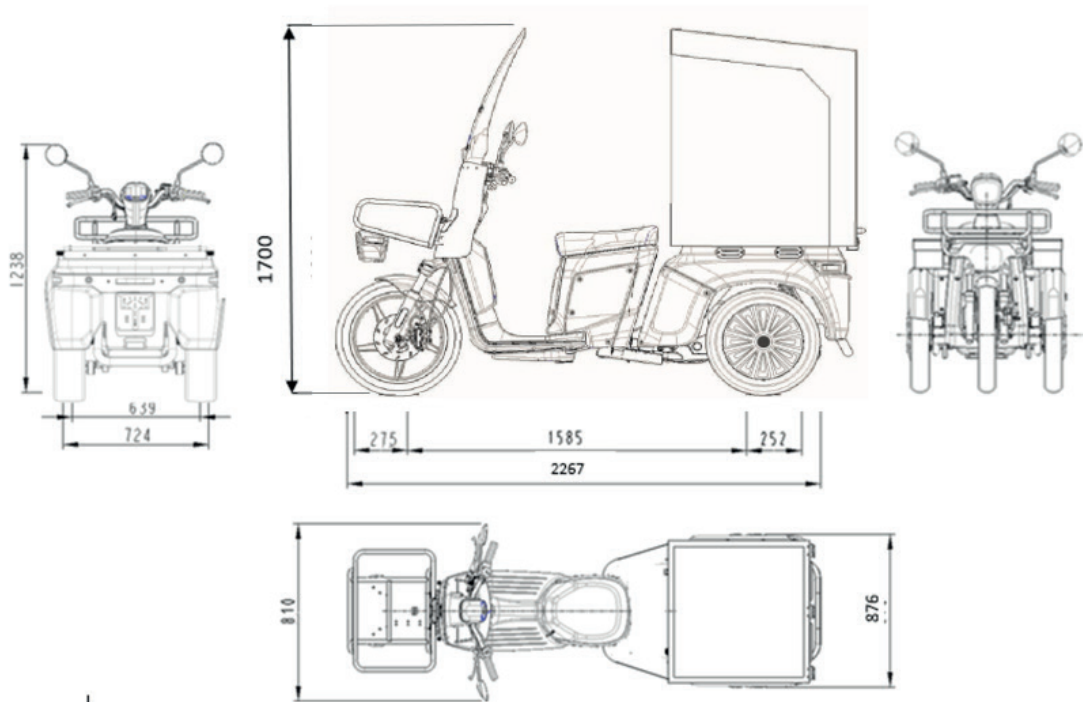

| | |
|------------------------------|---|
| MODEL | eSpro 3 |
| MOTOR DATA | |
| Model | Brushless permanent magnet sinusoidal motor |
| Motor type (Number 2 motors) | EME 202 (belt pulley transmission) |
| Regeneration | Automatic |
| MAX Power | Two 4.1 kW motors, total 8.2 kW * with four batteries connected and the same charge according to EU Regulation 168/2013, WMTC test cycle |
| Maximum torque at the wheel | 2x155 Nm =310 Nm |

| | |
|-----------------------|--|
| BATTERIES | |
| Model | TC116 - Energy 6,8 kWh (4x1.7KWhr) |
| Voltage and capacity | 54V - 126 Ah (4x31,5 Ah) |
| Power socket | Scame |
| Swappable | Yes |
| Charge | LI - ION |
| Battery single weight | 8 kg (battery 1.7KW) tot. 32 kg (4x8) |
| Autonomy * | With four 1.7 kWh batteries, 120 km and consumption of 89.7 Wh/km With four batteries connected and at the same charge according to 168/2013 EU WMTC test cycle |
| Operating temperature | Operating -20°C to +45°C |
| Batteries number | 4 |
| Vehicle category | L5e-A |

TECHNICAL DATA

| MODEL | eSpro 3 |
|--|---|
| Vehicle data | |
| Length | 2267 mm |
| Steering width | 810 mm |
| Rear width | 876 mm |
| Vehicle wheelbase | 1598 mm |
| Mirror mounting height | 1094 mm |
| Overall height with windshield | 1700 mm |
| Height to the battery compartment floor | 770 mm |
| Saddle height | 760 mm |
| Front tire pressure | 200+/-10 kPa (2 bar) |
| Rear tire pressure | 200+/-10 kPa (2 bar) |
| Front tire size | 90/80-16, 45J, rim 16"x2,15" |
| Rear tire size | 145/60-13, 51J, rim 13"x4.00B |
| Vehicle weight in running order | 204 kg |
| Frame | Tubular |
| Maximum permissible weight | 420 Kg (vehicle + driver + additional load) |
| Maximum permissible weight of the rear bed | 60 Kg (10 on the upper floor + 50 on the lower floor) |
| Maximum permissible weight on the front rack | 20 kg centered on the rack |
| Seat | 1 seat |
| Transmission | Mixed poly-v / toothed belts |
| Maximun speed | Limited to 65 km/h |
| Reverse speed | Limied to 4 km/h |

| FRONT LIGHT GROUP | |
|--------------------------|------------|
| Front light | LED |
| Direction indicators | LED |
| Dashboard lights | Colour LED |

| REAR LIGHT GROUP | |
|-------------------------|-----|
| Rear light | LED |
| Stop light | LED |
| Direction indicators | LED |
| licence plate light | LED |

TECHNICAL DATA

| | |
|------------------------|-------------------------------|
| MODEL | eSpro 3 |
| CYCLING | |
| Front suspension | Hydraulic fork |
| Rear suspension | 2 x spring shock absorber |
| Central tilting system | +/- 35° |
| Braking system | Hydraulic with integrated CBS |
| Front brake | Disc 220mm |
| Rear brake | 2 x discs 190mm |

| | |
|----------------------------|--|
| MODEL | eSpro 3 |
| GENERAL INFORMATION | |
| Connettivity | Present |
| Parcking brake | Electric |
| Reverse | Yes, with light and sound indication |
| USB Socket | USB/USBc (12V) |
| Parcking sensor | Optional (to be requested at the time of purchase) |

| | |
|--------------------|------------------------------|
| ACCESSORIES | |
| Rear box | h=1020mm, L= 860mm, P= 817mm |
| Front basket | L= 420mm, P= 330mm |
| Letter bag | Available |
| Front case | Optional |

| | |
|---|-------|
| VEHICLE COLOUR | |
|  | WHITE |

| | |
|------------|---|
| Autonomy * | <p>The stated range is based on the WMTC (World Motorcycle Test Cycle). It is not a fixed value and may not reflect actual riding experience on the road. WMTC tests are conducted under standardized laboratory conditions and may not reflect real-world conditions, leading to discrepancies, with actual range in some cases being up to 30% less than the homologation data.</p> <p>Factors that influence real autonomy:</p> <ul style="list-style-type: none"> • Driving style: Rapid acceleration and high speeds significantly reduce range. • Climate conditions: Extreme temperatures (very cold or very hot) negatively affect the vehicle's range. • Speed: The autonomy decreases drastically when travelling constantly at maximum speed, in this condition of use the kilometres that can be travelled can be significantly reduced compared to those declared. • Traffic and route: urban or extra-urban routes, climbs and descents influence consumption. |
|------------|---|

GENERAL WARRANTY CONDITIONS

1. Contents of the conventional warranty

- 1.1. Askoll EVA s.r.l., a single-member company with registered office at Via Industria, 30, 36031 Dueville (VI), Italy, tax code and Vicenza Registry number 03873430247 (hereinafter, for brevity, "Askoll"), a company belonging to the group managed and coordinated by Askoll Holding S.r.l., warrants that each electric vehicle it produces (hereinafter, for brevity, the "Electric Vehicle"), including the related Askoll-branded components and accessories, is free from design and/or manufacturing defects (hereinafter, for brevity, the "Warranty") under these terms and conditions (hereinafter, for brevity, the "Warranty Conditions").
- 1.2. The Warranty begins at 00:00 on the day of delivery of the Electric Vehicle by the authorized Askoll sales outlet to the first purchaser (hereinafter, for brevity, the "Customer") and will have a duration of:
- (a) 12 (twelve) months for Electric Vehicles sold to Customers other than consumers, such as professionals, legal entities, and private or public entities (hereinafter, for brevity, the "Professionals").
 - (b) 24 (twenty-four) months for Electric Vehicles sold to Customers classified as "consumers" pursuant to Legislative Decree no. 206 of 6 September 2005 (hereinafter, the "Consumer Code") or applicable national legislation (hereinafter, for brevity, the "Consumers").
- The warranty excludes components of the Electric Vehicle subject to loss of efficiency, such as, but not limited to: tires, belts, flexible controls, friction parts such as brake pads, vehicle batteries if not properly maintained, etc. This period is intended to be valid both for Customers classified as "consumers" pursuant to Legislative Decree no. 206 of 6 September 2005 (hereinafter the "Consumer Code") and for Customers other than consumers, such as professionals, legal entities, and private or public entities. The Warranty will be considered valid only and exclusively if the user Customer carries out proper maintenance of the vehicle in his/her possession by carrying out the operations described in the Maintenance Table indicated in the Use and Maintenance Manual.
- These activities must be carried out at Askoll-authorized service centers, and the operations must be recorded by the authorized center in this manual and on the dedicated portal. The Warranty will be considered valid only if the Customer performs proper maintenance on the vehicle in his/her possession by carrying out the operations described in the Maintenance Table indicated in the Use and Maintenance Manual. These activities must be carried out at Askoll-authorized service centers, and the interventions must be recorded in the present document.
- 1.3. The validity of the Warranty, in the event of transfer of ownership of the Electric Vehicle, continues regardless of the change in ownership of the vehicle itself under the conditions set forth in these Warranty Conditions.
- 1.4. Where a design and/or manufacturing defect is found, reported in accordance with the Warranty Conditions, the Customer has the right to free repair of the defect at the Askoll service network.
- 1.5. Askoll will cover the costs of repairs or replacements of defective parts and the labor required for such repairs or replacements. The choice of remedy between repair or replacement (which may be carried out using replacement material, when the technical characteristics allow, or new) is up to Askoll based on the extent of the defect and the economic convenience of one remedy compared to the other, without prejudice to the quality, safety, and reliability of the repair or replacement itself. If repairing the defect is impossible, excessively expensive, or ultimately uncertain, Askoll may replace the electric vehicle free of charge with a new factory-issued one of the same model as the replacement item.

GENERAL WARRANTY CONDITIONS

1. Contents of the conventional warranty

- 1.6. If, during the repair, it is found that the work is not covered by the Warranty, the cost of the repair must be covered in full by the owner of the vehicle.
- 1.7. Defective parts replaced under warranty become the property of Askoll.
- 1.8. The time required for repairs does not extend the warranty period. Repairs and/or replacements, as well as new parts replaced under warranty or repaired during the term of the legal warranty, do not start a new two-year limitation period for the replaced part. Instead, the term relating to the first delivery of the goods continues to run, depending on the duration of the warranty period applicable to the first purchaser of the Electric Vehicle being repaired. If, however, the spare part is replaced after the term of validity of the legal warranty for the complex good, the replaced part will be covered by the two-year legal warranty starting from the time of delivery or installation. In essence, the legal warranty applies to "spare parts" only if their replacement occurs outside the warranty period.
- 1.9. The Warranty does not cover mobility services.

2. Exclusions

- 2.1. Normal maintenance services for the Electric Vehicle are excluded from the Warranty.
- 2.2. Components of the Electric Vehicle subject to loss of efficiency, wear, or deterioration as a result of normal use or operation of the Electric Vehicle are excluded from the Warranty (such as, but not limited to: tires, belts, flexible controls, friction parts such as brake pads, the vehicle battery).
- 2.3. The Warranty does not apply to defects other than those of design or manufacturing; therefore, the Warranty does not specifically cover, but not limited to, any repairs or replacements for faults and/or malfunctions due to or deriving, directly or indirectly, from:
 - a) fortuitous events or causes of force majeure (such as, but not limited to: oxidation or other phenomena caused by the action of atmospheric agents due to abnormal environmental conditions or circumstances);
 - b) use of the Electric Vehicle that is not compliant with or in any way inconsistent with the instructions, warnings, and recommendations contained in the Use and Maintenance Manual (including, by way of example, failure to wash the electric vehicle correctly according to the instructions contained therein);
 - c) modifications, repairs, or other interventions that do not comply with the modification, repair, or disassembly standards prescribed by Askoll;
 - d) installation of parts and/or spare parts that do not comply with those prescribed or whose use is not approved by Askoll;
 - e) improper use of the Electric Vehicle or use other than private use (such as, for example, use in sporting competitions of any kind or use in rental services, public transport, etc.);
 - f) fraud, negligence, incompetence, or recklessness on the part of the owner or driver.
 - g) accidents, such as collisions with other vehicles, people, animals, identified or unidentified objects, rollovers, road departures, and acts of vandalism;
 - h) external causes and/or foreign bodies (such as, but not limited to, flat tires, broken windows, etc.);

GENERAL WARRANTY CONDITIONS

2. Exclusions

- i) normal wear and tear of the Electric Vehicle resulting from its use, which means the loss of efficiency, deterioration, and wear that any material, part, component, and mechanical part suffers solely from prolonged use; wear and tear is identified by comparing the condition, mileage, and usage time observed on the damaged parts with the potential average operating time normally attributed to them; the inspection will be entrusted to an expert if necessary.

3. Customer Obligation

- 3.1. The Warranty will only be valid if the lack of conformity has been reported, in writing, by the Consumer Customer no later than 2 (two) months after discovery and by the Professional Customer no later than 8 (eight) days after discovery.
- 3.2. The Customer is responsible for reporting the lack of conformity within the aforementioned deadlines by contacting the authorized Askoll sales outlets available on the Askoll website <http://askollelectric.com>.
- 3.3. The Customer must present a copy of the proof of purchase (receipt or invoice) or other supporting document demonstrating the operation and validity of the Warranty.
- 3.4. In the event of failure to comply with the provisions of the previous paragraphs, the Warranty will not be applicable and the Customer will forfeit the right to the relevant services.
- 3.5. The validity of this Warranty, in the event of transfer of ownership of the Electric Vehicle, continues regardless of any change in ownership of the vehicle, without prejudice to the obligation of the new purchaser to present the original purchaser's proof of purchase. The new owner is, however, invited to promptly notify Askoll of any change in ownership of the electric vehicle using the methods available on the Askoll website www.askoll.com or <http://askollelectric.com>, also to allow Askoll to provide targeted communication in the event of any recalls relating to safety or updates to certain parts.
- 3.6. The Warranty does not cover mobility services; therefore, the Customer must deliver, at his/her own expense, the Electric Vehicle to an authorized Askoll sales point or, by prior telephone arrangement, directly to the authorized service centers. Upon specific request, a service may be offered to collect the Electric Vehicle from the Customer's home, at the Customer's expense, or assistance may be offered at the Customer's home, at the Customer's expense. In exceptional cases, where the defect covered by the Warranty makes it impossible for the motorcycle to be driven, the costs of motorcycle collection or home assistance will be agreed upon with Askoll in advance.
- 3.7. The Customer must cooperate in the most correct execution of the assistance activities, providing the Askoll assistance network with any information regarding the circumstances in which the defect arose, as well as any information and clarifications that Askoll, directly or through the assistance network, may request.
- 3.8. The Warranty applies to defects ascertained by Askoll through its assistance network; if Askoll does not deem the Warranty applicable and a dispute arises with the Customer, the repair operations will be suspended pending the expert's assessment.
- 3.9. The Warranty will be considered valid only if the Customer performs proper maintenance on the vehicle in his/her possession by carrying out the operations described in the Maintenance Table. These activities must be carried out at Askoll-authorized service centers, and the interventions must be recorded in this manual and on the portal made available to the authorized service centers.

GENERAL WARRANTY CONDITIONS

4. Limitations of liability

- 4.1. Except as provided by mandatory national legislation applicable to the relationship between the “consumer” and the manufacturer and the provisions on the manufacturer’s civil liability, Askoll will not be liable for damage to property and/or persons in any way caused by the Electric Vehicle, its use, malfunction, or immobilization due to faults.
- 4.2. Any downtime of the Electric Vehicle or delays in repairs or replacements relating to the Electric Vehicle entrusted to the Askoll service network do not entitle the user to any compensation or expense reimbursement (such as, for example, costs for replacement vehicles) from Askoll or to any extension of the Warranty.
- 4.3. Any compensation for loss of economic earnings resulting from the malfunction of the Electric Vehicle or other costly consequences of the defect itself is excluded.

5. Nature of this warranty

- 5.1. This warranty is governed solely by these Warranty Conditions and by Italian law, without prejudice to the possible application of mandatory provisions for the protection of the consumer provided for by the legislation applicable in the country of residence of the Customer, classified as a “consumer” pursuant to Legislative Decree no. 206 of 6 September 2005 of the Italian Republic (hereinafter the “Consumer Code”) or pursuant to similar codes or similar national regulations applicable in the country of residence of the Customer (hereinafter for brevity the “Consumer Customers”).
- 5.2. This Warranty is a conventional warranty pursuant to Article 133 of the Consumer Code.
- 5.3. This Warranty, subject to the Warranty Conditions, constitutes the only conventional warranty offered by Askoll as the manufacturer of Askoll-branded electric vehicles.
- 5.4. These Warranty Conditions do not affect the mandatory rights towards the seller recognized by the natural person defined as a “consumer” pursuant to the Consumer Code or applicable national regulations.
- 5.5. Except for Consumer Customers or where otherwise provided by a mandatory provision in force in the Customer’s country, any disputes relating to these Warranty Conditions shall be subject to the exclusive jurisdiction of the Court of Vicenza, Italy.

GENERAL WARRANTY CONDITIONS

| |
|---|
| 6. Maintenance booklet Scooter Service |
|---|

| | | | |
|-----------------------|--------------|--|---------------------|
| Owner | Date: | service check within to 2000 Km | |
| Surname: | | Mileage | Next service |
| Name: | | Dealer's stamp | |
| Interventions: | | | |
| | | | |
| | | | |
| | | | |

| | | | |
|-----------------------|--------------|--|---------------------|
| Owner | Data: | service check within to 6000 Km | |
| Surname: | | Mileage | Next service |
| Name: | | Dealer's stamp | |
| Interventions: | | | |
| | | | |
| | | | |
| | | | |

| | | | |
|-----------------------|--------------|---|---------------------|
| Owner | Data: | service check within to 12000 Km | |
| Surname: | | Mileage | Next service |
| Nome: | | Dealer's stamp | |
| Interventions: | | | |
| | | | |
| | | | |
| | | | |

GENERAL WARRANTY TERMS AND CONDITIONS

6. Maintenance booklet Scooter Service

| | | | |
|-----------------------|--------------|-------------------------------------|---------------------|
| Owner | Date: | Service due within 18.000 Km | |
| Surname: | | Mileage | Next Service |
| Name: | | | |
| Interventions: | | Dealer's Stamp | |
| | | | |
| | | | |
| | | | |
| | | | |

| | | | |
|-----------------------|--------------|-------------------------------------|---------------------|
| Owner | Date: | Service due within 24.000 Km | |
| Surname: | | Mileage | Next Service |
| Name: | | | |
| Interventions: | | Dealer's Stamp | |
| | | | |
| | | | |
| | | | |
| | | | |

| | | | |
|-----------------------|--------------|-------------------------------------|---------------------|
| Owner | Date: | Service due within 30.000 Km | |
| Surname: | | Mileage | Next Service |
| Name: | | | |
| Interventions: | | Dealer's Stamp | |
| | | | |
| | | | |
| | | | |
| | | | |

GENERAL WARRANTY TERMS AND CONDITIONS

| |
|---|
| 6. Maintenance booklet Scooter Service |
|---|

| | | | |
|-----------------------|--------------|-------------------------------------|---------------------|
| Owner | Date: | Service due within 36.000 Km | |
| Surname: | | mileage | Next Service |
| Name: | | Dealer's stamp | |
| Interventions: | | | |
| | | | |
| | | | |
| | | | |

| | | | |
|-----------------------|--------------|-------------------------------------|---------------------|
| Owner | Date: | Service due within 42.000 Km | |
| Surname: | | mileage | Next Service |
| Name: | | Dealer's stamp | |
| Interventions: | | | |
| | | | |
| | | | |
| | | | |

| | | | |
|-----------------------|--------------|-------------------------------------|---------------------|
| Owner | Date: | Service due within 48.000 Km | |
| Surname: | | mileage | Next Service |
| Name: | | Dealer's stamp | |
| Interventions: | | | |
| | | | |
| | | | |
| | | | |

GENERAL WARRANTY TERMS AND CONDITIONS

6. Maintenance booklet Scooter Service

| | | | |
|-----------------------|--------------|-------------------------------------|---------------------|
| Owner | Date: | Service due within 54.000 Km | |
| Surname: | | Mileage | Next Service |
| Name: | | | |
| Interventions: | | Dealer's stamp | |
| | | | |
| | | | |
| | | | |
| | | | |

| | | | |
|-----------------------|--------------|-------------------------------------|---------------------|
| Owner | Date: | Service due within 60.000 Km | |
| Surname: | | Mileage | Next Service |
| Name: | | | |
| Interventions: | | Dealer's stamp | |
| | | | |
| | | | |
| | | | |
| | | | |

| | | | |
|-----------------------|--------------|-------------------------------------|---------------------|
| Owner | Date: | Service due within 66.000 Km | |
| Surname: | | Mileage | Next Service |
| Name: | | | |
| Interventions: | | Dealer's stamp | |
| | | | |
| | | | |
| | | | |
| | | | |

NOTE

EAN CODE

Serial number

QR CODE

Askoll EVA SpA
Via Industria, 30
36031 Dueville (VI) Italia
Tel. 0444 930260
www.askollelectric.com

E3285000