

Welcome to the age of the electric!

Congratulations on having chosen a more sustainable approach to mobility: low consumption, great savings and more breathable air, as well as guaranteed autonomy; to do yourself, others and the planet good.

Congratulations on having decided to embrace a new lifestyle and innovative thinking: taking advantage of cutting-edge technology such as electric has only positive implications.

With the purchase of Askoll eSPRO 45, eSPRO 70, eSPRO 45K, eSPRO 70K o eSPRO K1 2 Seats you will finally be able to enjoy a vehicle that concentrates the best of Askoll functionality, design and technology, a company that boasts thirty years of experience in the design and manufacture of electric motors.

This manual has been prepared to allow you to fully appreciate its qualities. It contains information, warnings and advice regarding the correct use and maintenance of your new vehicle.

It is important to read it in its entirety before driving the vehicle for the first time. You will also discover details and characteristics that will help convince you of your excellent choice.

This publication is to be considered an integral part of the vehicle. If the vehicle is sold, it must be handed over to the new owner.

EN

The constant evolution in design, to guarantee the safety and quality standard of Askoll vehicles, may result in the fact that some information contained in this Use and Maintenance Booklet may differ from the vehicle in your possession. We are sure that you will understand, therefore, that the data, figures and descriptions shown here cannot constitute a basis for any claim..

INDEX

INDEX	II
GENERAL INFORMATIONS	1
SYMBOLOLOGY	1
IMPORTANT SAFETY INFORMATION	2
IDENTIFICATION	3
CONTROLS AND INSTRUMENTS	4
GENERAL VIEW OF THE SCOOTER	4
eSPRO 45 left side	4
eSPRO 45 right side	4
eSPRO 70 left side	5
eSPRO 70 right side	5
eSPRO 45K left side	6
eSPRO 45K right side	6
eSPRO 70K left side	6
eSPRO 70K right side	6
eSPRO K1 2 Seats left side	7
eSPRO K1 2 Seats right side	7
POSITION OF CONTROLS AND INSTRUMENTS	8
DASHBOARD	8
LEFT CONTROL UNIT	8
Rear brake lever	9
Rear brake lever with combined function (eSPRO70 e eSPRO70K)	9

Energy regeneration mode selector	9
Flasher switch	10
Horn button	10
RIGHT CONTROL UNIT	11
Front brake lever	11
Throttle control	11
High beam headlight switch	12
Driving mode selector	12
Engine start button	13
KEY SWITCH	13
System enabling and disabling	13
INSTRUMENTATION	14
LUMINOUS INDICATORS	15
High temperature indicator	16
Severe problem indicator	16
Indicator blinkers in operation	17
Lights indicator in operation	17
High beam indicator	17
Charging indicator	17
OBD Error Detection Diagnostic System Indicators (only Euro5)	17
SPEEDOMETER (eSPRO45 - eSPRO45K - eSPRO70 - eSPRO70K- eSPROK 2 Seats)	18
MENU SETTING BUTTONS	18

INDEX

DIGITAL DISPLAY (eSPRO45 - eSPRO45K - eSPRO70 - eSPRO70K- eSPROK 2 Seats)	19
USE	20
CHECK BEFORE DEPARTURE	20
SAFE DRIVING	20
OPERATIONS FOR STARTING	22
Engaging and disengaging the steering lock	22
Motor enabling	23
Driving mode selection (eSPRO45 - eSPRO45K - eSPRO70 - eSPRO70K- eSPROK 2 Seats)	24
Energy regeneration mode selection	26
SELECTION OF DISPLAY FUNCTIONS	27
Odometer data display mode	27
Vehicle autonomy	27
Adjusting the clock function	28
BLUETOOTH®	29
Connectivity	29
Application “ASKOLL DRIVE SMART”	29
OBD DIAGNOSTICS (only Euro5)	30
SADDLE	31
Saddle opening	31
Bag hook	31
STOP THE SCOOTER	32
BATTERY AND CHARGING	33

BATTERIES	33
Battery management in the first use of the scooter	33
Percentage of charge	34
Disposal of exhausted batteries	37
CHARGER	38
SMART CHARGER	39
Functions of the charger	39
Turn on the fans	40
Charge splitter accessory	40
CHARGING THE BATTERIES	42
CHARGING WITH BATTERY ON BOARD	43
Locking of the saddle in a raised position for the passage of the cable	44
CHARGING WITH OFF-BOARD CHARGER	46
ADJUSTMENTS AND PERIODIC MAINTENANCE	50
ADJUSTMENTS	50
REARVIEW MIRRORS	50
FRONT HEADLIGHT	50
FRONT DISC BRAKE	51
REAR DRUM BRAKE (eSPRO45 - eSPRO45K - eSPROK1 2 Seats)	52
REAR DISC BRAKE (eSPRO70 - eSPRO70K)	53
REAR DISC BRAKE WITH COMBINED FUNCTION (eSPRO70 - eSPRO70K)	53
ORDINARY MAINTENANCE PROCEDURES	54





INDEX

TIRES	54
CHECKING THE FRONT BRAKE FLUID LEVEL	55
CHECKING THE REAR BRAKE FLUID LEVEL (only eSpro 70 - eSpro 70K Euro5)	56
HEADLIGHT (eSpro45 - eSpro 70 Euro5)	57
REAR LIGHT UNIT AND DIRECTION INDICATORS	57
REPLACING FRONT LIGHT BULB (eSpro45 K- eSpro 70 K EURO5 - eSpro K1 2 P SEATS)	58
FRONT LIGHT (eSpro45 K- eSpro 70 K EURO5 - eSpro K1 2 SEATS)	59
SUMMARY TABLE OF ORDINARY MAINTENANCE PROCEDURES	60
CLEANING THE VEHICLE	61
INACTIVITY OF THE VEHICLE	62
ERROR CODES	63
ERROR CODES	63
TECHNICAL DATA	66
DIMENSIONS OF THE SCOOTER	66
ENGINE DATA	69
BATTERY	69
VEHICLE DATA	70
FRONT LIGHT UNIT DATA	70
REAR LIGHT UNIT DATA	70
EU DECLARATION OF CONFORMITY	71

SYMBOLOLOGY







The manual contains particularly important information on which it is necessary to focus more carefully.

Each sign consists of a different symbol to make the content of the text that follows it clear and to facilitate the placement of topics in the different areas.

 WARNING	This symbol indicates particularly hazardous situations which, if not avoided, could result in death or serious injury.
	This version of the warning sign will be used throughout the manual.
WARNING	This symbol indicates a generic safety notice. It is used to warn you of the potential danger of damage to people and / or vehicles.
	Failure or incomplete compliance with these prescriptions may be the cause of any serious damage to the vehicle and in some cases the invalidation of the warranty..
	The correct behaviors to be followed are indicated in order not to cause damage to nature through the use of the vehicle.

GENERAL INFORMATIONS

IMPORTANT SAFETY INFORMATION

	It is of fundamental importance for you to know the electric scooter: read and understand this manual before using it for the first time.
	This operating manual is an integral part of the scooter, keep it for future reference. In case of sale it must be handed over to the next owner.
	The scooter is not intended to be used by people whose physical, sensory or mental capacities are reduced, or with a lack of experience or knowledge, unless they have been able to benefit, through the intermediation of a person responsible for their safety. , supervision or instructions regarding the use of the scooter.
  	Failure or incomplete compliance with these requirements may be the cause of any serious damage to people, the vehicle, the environment and in some cases the forfeiture of the warranty.
	Any processing that modifies the performance or the main structure of the scooter, in addition to being prohibited by law, makes the vehicle no longer compliant with the approval and, therefore, dangerous for safety.

IDENTIFICATION

The identification numbers are stamped on the frame, on the crankcase and in the battery compartment. They must always be indicated in requests for spare parts.

It is advisable to check the correspondence of the vehicle serial numbers with those reported on the documents of the same.

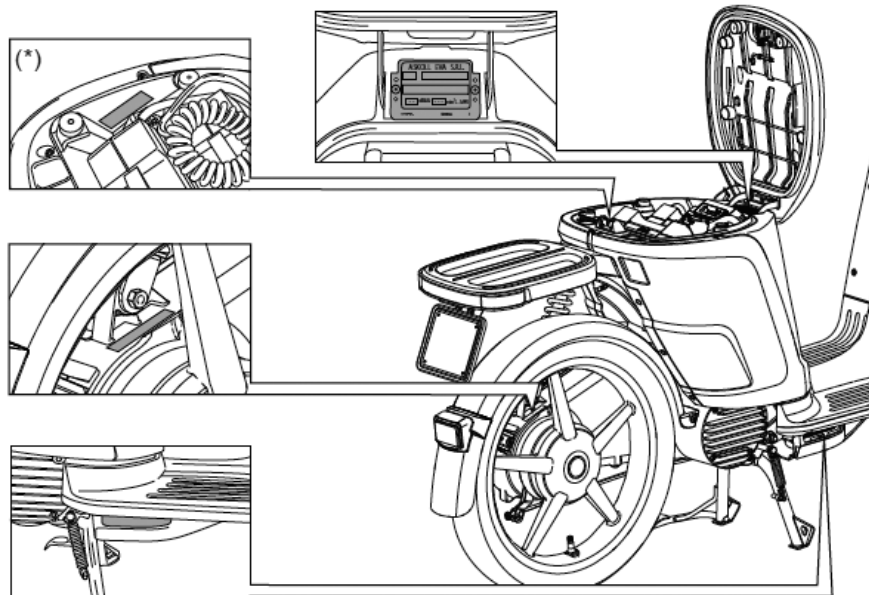

EN

WARNING



Altering the identification numbers can lead to serious criminal penalties.

CONTROLS AND INSTRUMENTS

GENERAL VIEW OF THE SCOOTER

eSPRO 45 left side

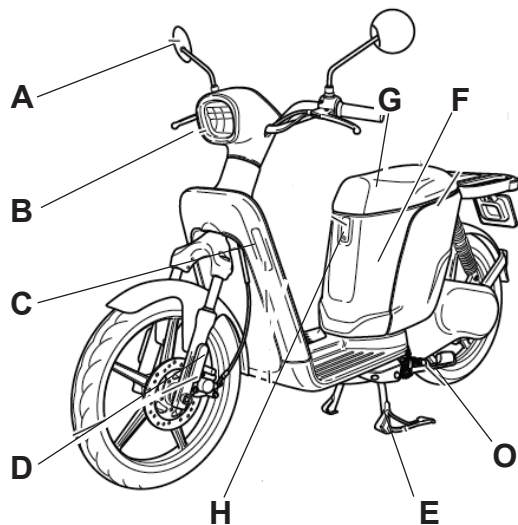

- A. Rearview mirror
- B. Front light unit
- C. Direction indicator
- D. Left front reflector
- E. Kick stand
- F. Battery compartment
- G. Saddle
- H. Bag hook

eSPRO 45 right side

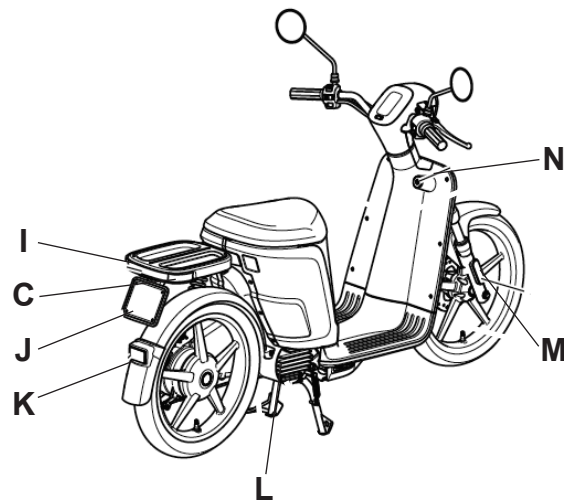

- I. Rear light unit
- J. License plate
- K. Rear reflector
- L. Motor
- M. Right front reflector
- N. Ignition switch
- O. Lateral kick stand

CONTROLS AND INSTRUMENTS

GENERAL VIEW OF THE SCOOTER

eSPRO 70 left side

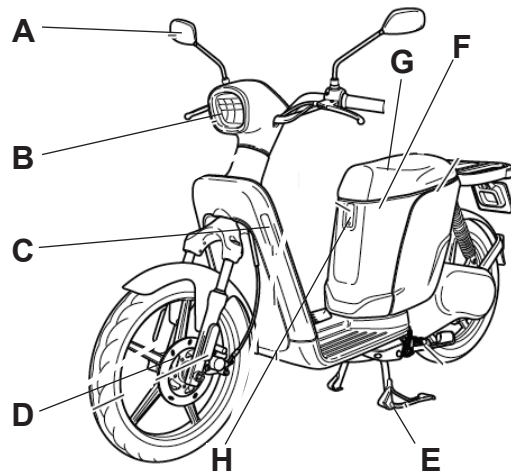

- A. Rearview mirror
- B. Front light unit
- C. Direction indicator
- D. Left front reflector
- E. Kick stand
- F. Battery compartment
- G. Saddle
- H. Bag hook

eSPRO 70 right side

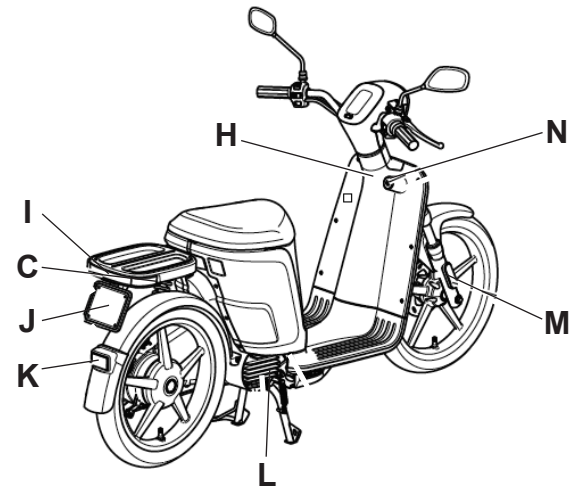

- I. Rear light unit
- J. License plate
- K. Rear reflector
- L. Motor
- M. Right front reflector
- N. Ignition switch

EN

CONTROLS AND INSTRUMENTS

GENERAL VIEW OF THE SCOOTER

eSPRO 45K - eSPRO 70K left side

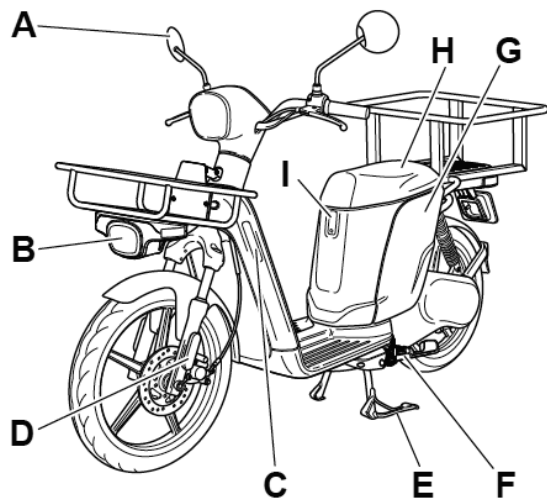

- A. Rearview mirror
- B. Front light unit
- C. Direction indicator
- D. Left front reflector
- E. Kick stand
- F. Lateral kick stand
- G. Battery compartment
- H. Saddle
- I. Bag hook

eSPRO 45K - eSPRO 70K right side

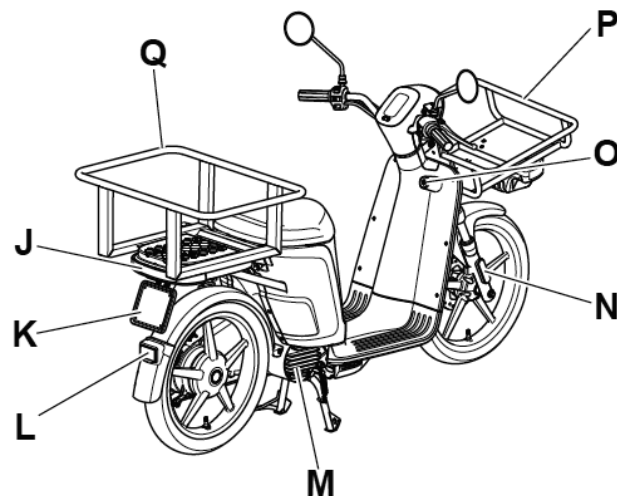

- J. Rear light unit
- K. License plate
- L. Rear reflector
- M. Motor
- N. Right front reflector
- O. Ignition switch
- P. Front carrier basket
- Q. Rear carrier basket (K2 version only)

CONTROLS AND INSTRUMENTS

GENERAL VIEW OF THE SCOOTER

eSPROK1 2 Seats left side

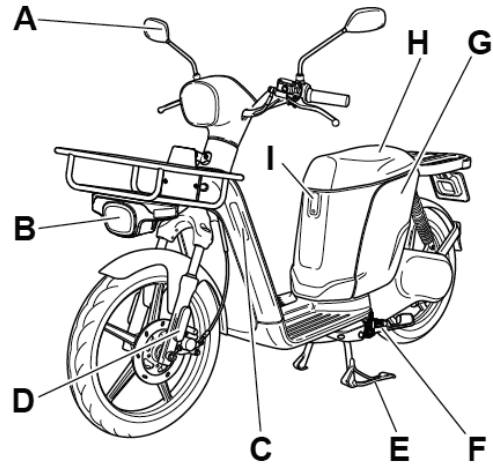

- A. Rearview mirror
- B. Front light unit
- C. Direction indicator
- D. Left front reflector
- E. Kick stand
- F. Battery compartment
- G. Saddle
- H. Bag hook

eSPROK1 2 Seats right side

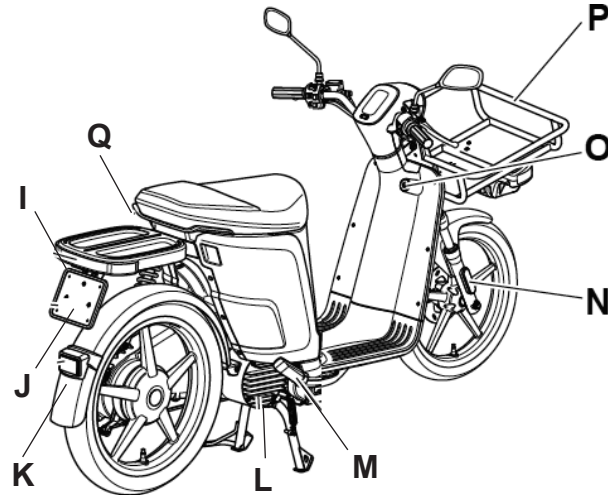

- I. Rear light unit
- J. License plate
- K. Rear reflector
- L. Motor
- M. Passenger footrests
- N. Right front reflector
- O. Ignition switch
- P. Front carrier basket
- Q. Passenger handle

EN

CONTROLS AND INSTRUMENTS

POSITION OF CONTROLS AND INSTRUMENTS

DASHBOARD COVER (eSPRO45 - eSPRO70- eSPRO45K- eSPRO70K - eSPROK1 2 Seats)

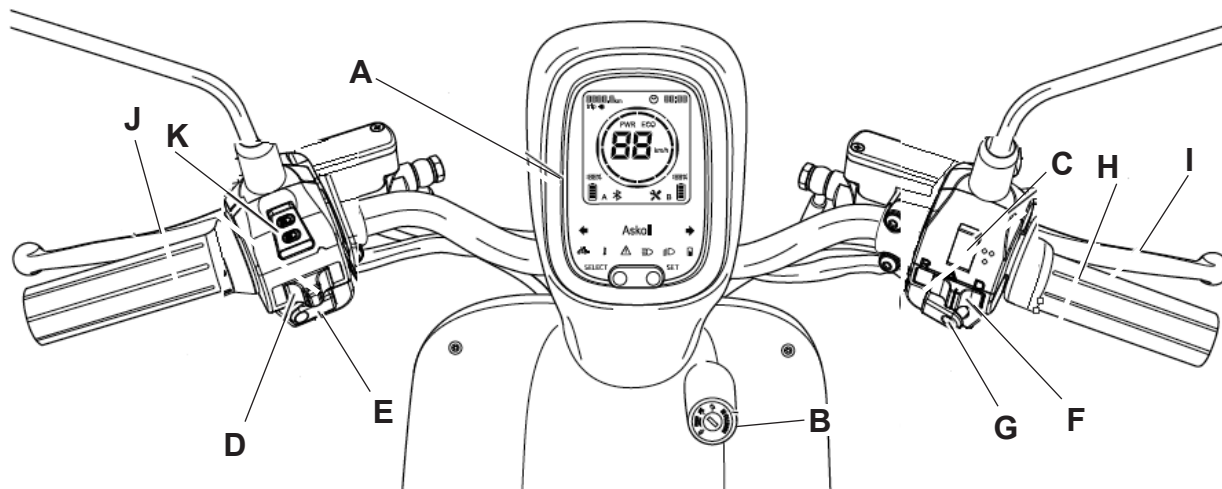

- A. Instrumentation
- B. Key switch
- C. Energy regeneration mode selector
- D. Flasher switch
- E. Horn button
- F. Front gear driving mode selector
+ Reverse gear + 4 parking direction indicators

- G. Engine start button /
MODE function selection of driving mode
- H. Throttle control
- I. Front brake lever
- J. Combined brake lever
- K. Headlight switch

LEFT CONTROL UNIT

Rear brake lever

The rear brake lever (drum for **eSPRO45**, **eSPRO45K** e **eSPROK1 2 Seats**, to disc for **eSPRO70** e **eSPRO70K**) is located on the left side of the handlebar.

Rear brake lever with combined function (only **eSPRO70** e **eSPRO70K**)

The brake acts on both wheels, with prevalence on the rear one to ensure greater safety and better stopping distances.

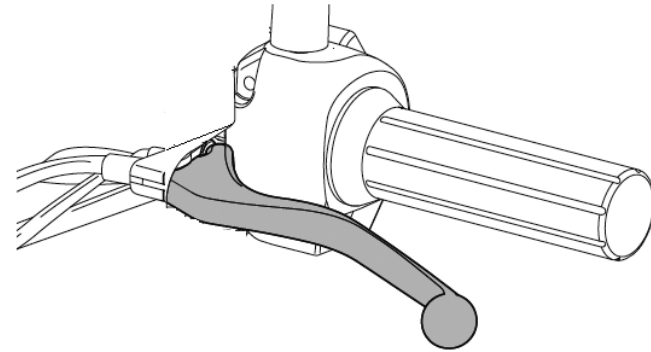

EN

Energy regeneration mode selector

When the scooter is decelerating, the battery can be automatically recharged by activating the energy regeneration mode.

Use the two-position switch to activate or deactivate the energy regeneration mode.

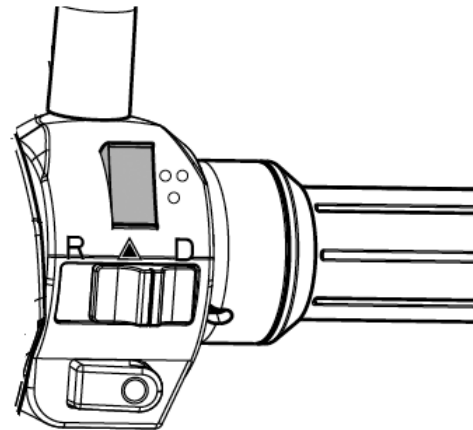

CONTROLS AND INSTRUMENTS

Flasher switch

Move the lever to the left to operate the left turn indicators.

Move the lever to the right to operate the right turn indicators.

Press the button in the center of the lever to turn off the Speedlights.

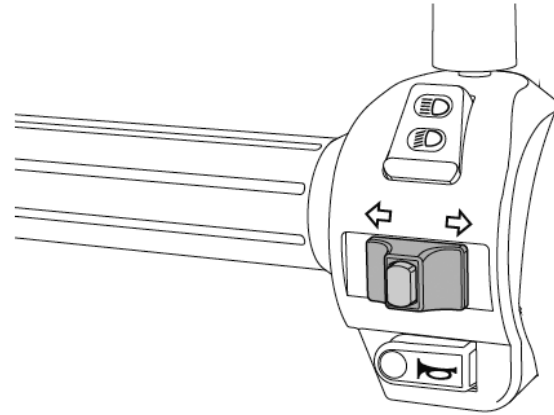

Horn button

Press to sound the horn.

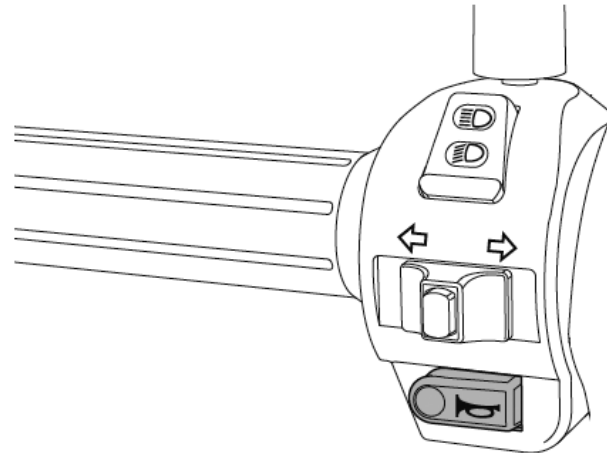

CONTROLS AND INSTRUMENTS

RIGHT CONTROL UNIT

Front brake lever

The front disc brake lever is located on the right side of the handlebar.

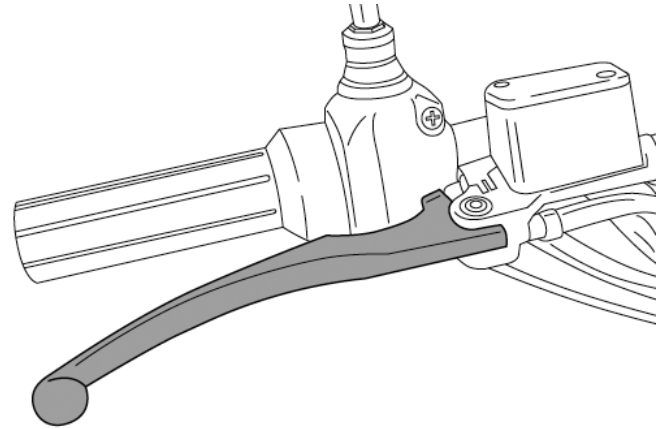

EN

Throttle control

The speed of the scooter is adjusted by turning the knob.

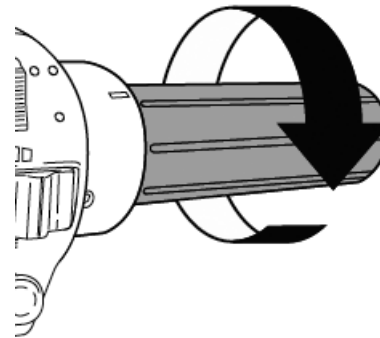

CONTROLS AND INSTRUMENTS

High beam headlight switch

Using the selector it is possible to activate the high beam.

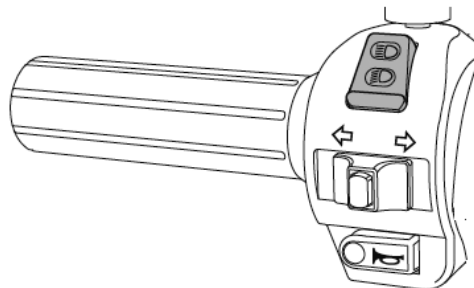

Driving mode selector

Using the switch it is possible to select three different modes

Position D = proceed with front gear

Position  = the 4 parking direction lights are activated

Position R = proceed with Reverse

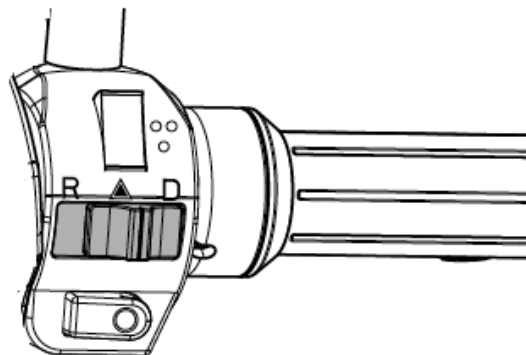

The reverse function must be engaged with the vehicle completely stationary, with both brakes applied, and with both feet on the ground. The maximum speed in reverse is 3Km / h, during the reverse maneuver the 4 parking arrows and the intermittent acoustic buzzer are automatically active. If during the front gear, the reverse gear is incorrectly engaged, the vehicle does not hear the command, the incorrect command is signaled on the dashboard by lighting the letter "R" intermittently on the number of km of the dashboard, the drive letter D remains active anyway, the acoustic buzzer is activated continuously.

CONTROLS AND INSTRUMENTS

Engine start button

Pressing the button for 3 seconds, depending on the position of the key in the switch, enables or disables the engine.

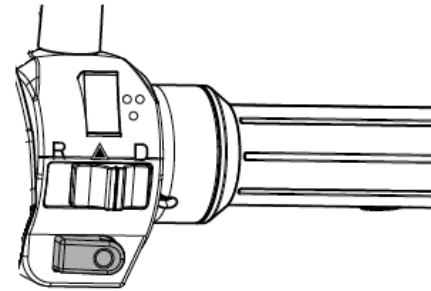

EN

KEY SWITCH

The key switch enables or disables the system and the steering lock.

The scooter is supplied with a master key and a duplicate that can be used both to operate the key switch and to open the saddle.

It is recommended that you keep the duplicate key separately from the master key.

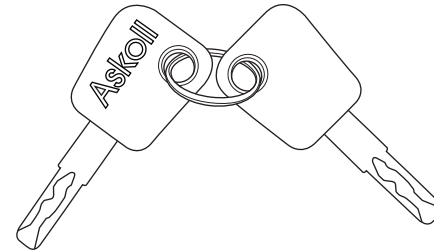

System enabling and disabling

Turning the key on  the system is enabled.

Turning the key on  you disable the system.

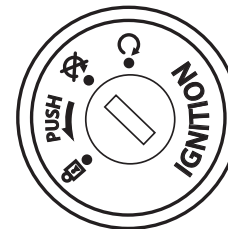

WARNING Do not turn or remove the key while driving

CONTROLS AND INSTRUMENTS

INSTRUMENTATION

eSPRO45 - eSPRO45K - eSPRO70 - eSPRO70K - eSPROK 2 Seats

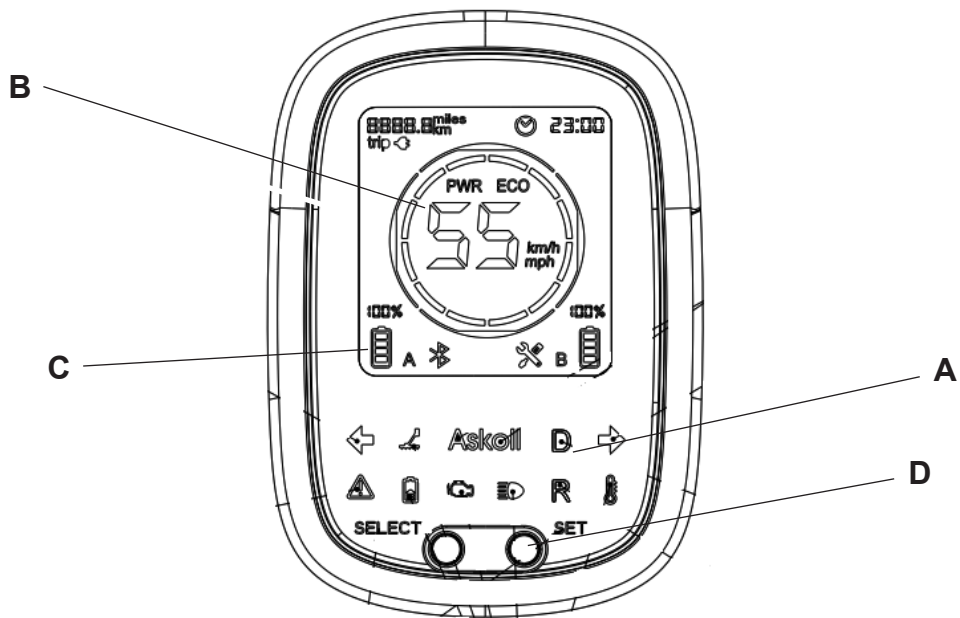

- A. Indicator lights
- B. Speedometer
- C. Digital display
- D. Display commands

CONTROLS AND INSTRUMENTS

INDICATOR LIGHT

- H. Indicators blinkers in operation
- L. Engine OBD Diagnostic Indicator
- K. High beam indicator in operation
- G. Severe problem indicator
- I. Front gear indicator
- F. High temperature indicator
- N. Reverse indicator in operation
- M. Kickstand OBD Diagnostic Indicator
- O. Charging indicator

eSPRO45 - eSPRO45K - eSPRO70 - eSPRO70K - eSPROK 2 Seats

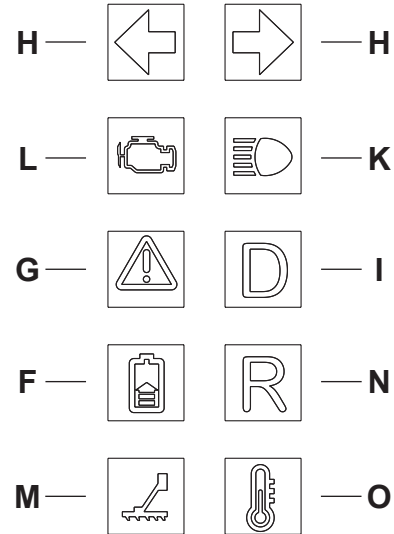

EN

CONTROLS AND INSTRUMENTS

High temperature indicator

The high temperature indicator light is amber in color, it turns on and remains steady to indicate an over-temperature alarm. The relative alarm code can be read on the display.

For the description of the alarm relating to the displayed code, refer to the “**ERROR CODES**” chapter.



Severe problem indicator

The serious problem indicator light is red, it lights up together with the malfunction light on the display.

When you turn on stop the vehicle, the related error code can be read on the display.

It is necessary to go to an authorized workshop to have the vehicle checked.

For the description of the alarm related to the displayed code, refer to the “**ERROR CODES**” chapter.



Indicator blinkers in operation

The indicator light is green, it turns on and flashes to indicate the insertion of the left or right direction indicator, it turns off by disabling the flashers.



Lights indicator in operation

The light switch is green, it comes on when the engine is enabled.



High beam indicator

The high beam warning light is blue, it comes on by operating the selector on the left switch.



Charging indicator

The charging indicator light is amber in color, it lights up and remains steady when the battery charger is connected to the mains and the batteries are being recharged. It also lights up when the energy regeneration mode is activated.



OBD Error Detection Diagnostic System Indicators (only eSPRO70 - eSPRO70K Euro5)

The On Board Diagnostic (OBD) system lights are amber and illuminate during communication between the vehicle and the external diagnostic device.

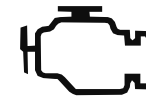

CONTROLS AND INSTRUMENTS

SPEEDOMETER (eSPRO45 - eSPRO45K - eSPRO70 - eSPRO70K- eSPROK 2 Seats)

The speedometer indicates the current speed. The value appears in kilometers per hour (km / h).

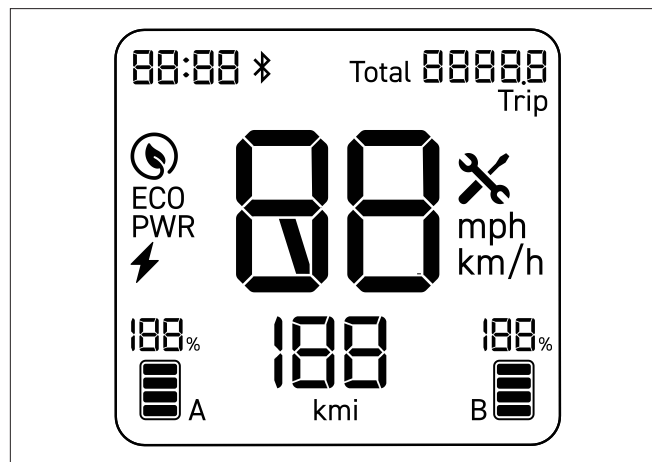

MENU SETTING BUTTONS

The SELECT and SET buttons must be used for:

- select the parameter to be shown on the display,
- reset the displayed value (km / trip),
- set and confirm new values (hour).

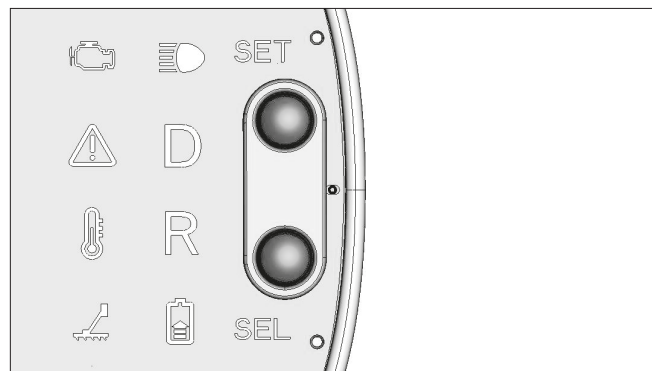

COMANDI E STRUMENTI

CONTROLS AND INSTRUMENTS

DIGITAL DISPLAY (eSPRO45 - eSPRO45K - eSPRO70 - eSPRO70K- eSPROK 2 Seats)

Through the digital display it is possible to have all the information on the status of the vehicle, more precisely:

- presence of the batteries in compartments A and B,
- state of charge of the batteries,
- total mileage traveled,
- partial mileage,
- kilometers that can be traveled with the remaining battery charge,
- Hour,
- alarms and related error codes.

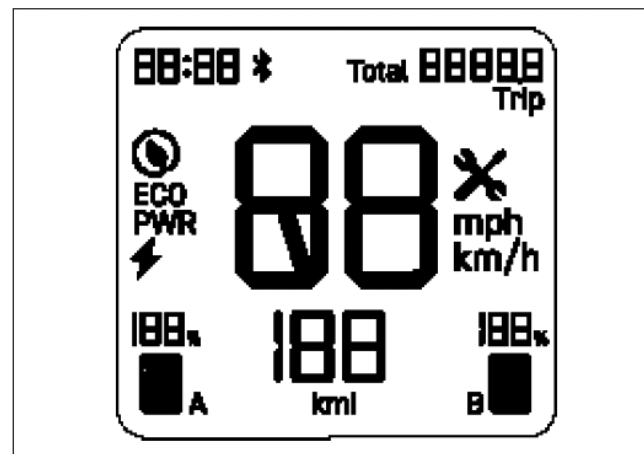

EN

USE

CHECK BEFORE DEPARTURE



Before using the scooter it is always a good idea to carry out some checks:

- check the state of charge of the batteries,
- check the operation of the front light, rear light, direction indicators and license plate light,
- check the operation of the front and rear brakes,
- check the fluid level in the front brake reservoir,
- check the tire pressure,
- check that the saddle is closed in a non-raised position and that the charger cables are correctly positioned in the battery compartment.

To carry out these checks correctly, refer to the instructions contained in this manual.

SAFE DRIVING

WARNING	Before the first use, we recommend that you try the scooter in areas closed to traffic until you acquire a good knowledge of it.
WARNING	Always drive within the limits of your abilities.
	Driving while intoxicated, under the influence of drugs or certain medicines is very dangerous for oneself and is prohibited by law.
WARNING	Before setting off, always wear a helmet and fasten it correctly.
WARNING	In case of passenger transport, before setting off, check that he has worn the helmet and that he has fastened it correctly.
WARNING	Recommend to the passenger to always remain firmly attached to the special handle while traveling.
WARNING	Avoid starting with the central stand down: when the rear wheel makes contact with the ground it must not turn to avoid an abrupt start.

WARNING	Su strade disconnesse, in caso di pioggia, neve o su strada scivolosa è necessario ridurre la velocità ed aumentare la distanza di sicurezza da altri veicoli, guidando con prudenza.
WARNING	Using the brakes, use them both to share the braking action on both wheels.
	Do not brake hard on wet, dirt or slippery road surfaces.
WARNING	After traveling a long wet stretch of road without using the brakes, the braking action will initially be less. It is advisable to periodically apply the brakes in these conditions.
	In case of rain, visibility decreases, reduce speed and drive carefully.
WARNING	On eS3 EVO vehicles, if during acceleration the rear brake is activated at the same time until the wheel is locked, this situation sends the control unit into protection and the vehicle switches off.

USE

OPERATIONS FOR STARTING

Engaging and disengaging the steering lock

To insert the steering lock, turn the handlebar to the left as far as it will go.

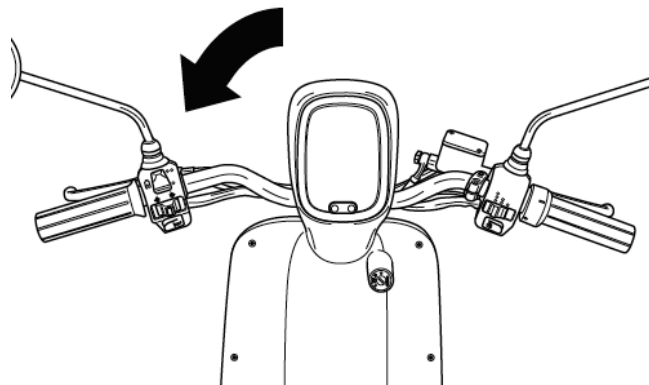

Press the key inwards and turn counterclockwise; at the same time turn the handlebar slightly clockwise until the key clicks on the padlock symbol; now the steering lock is engaged and the key can be removed.

To disengage the steering lock, insert the key into the switch and turn it to the right.

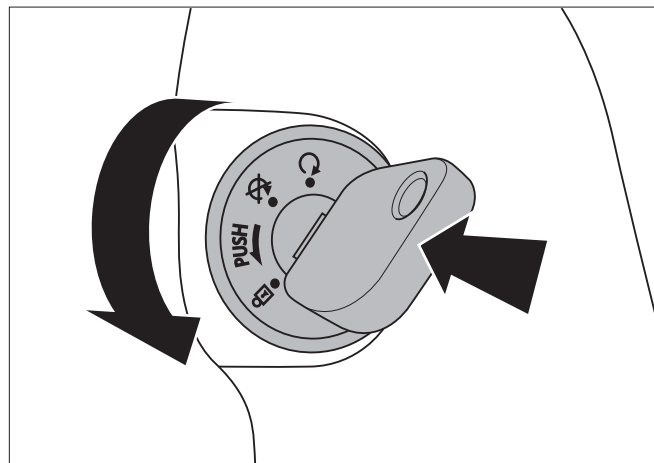

Motor enabling

In order to be able to start the engine, it must be enabled.

To enable the engine, insert the key into the switch and turn it on , then press the MODE button to enable the engine for 1 second, the ignition warning light comes on.

To disable the engine, press the engine enable MODE key again for 1 second and turn the key in the switch to the left .

The disabling of the motor takes place also with the only rotation on  of the key.

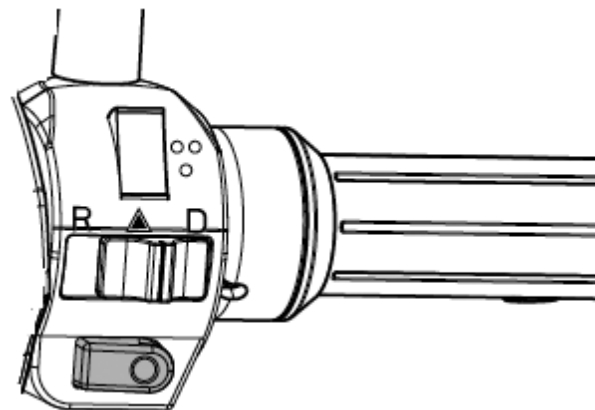

EN

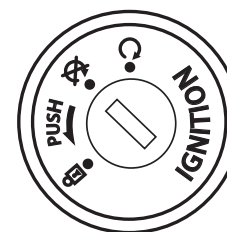

USE

Driving mode selection (eSPRO45 - eSPRO45K - eSPRO70 - eSPRO70K- eSPROK 2 Seats)

Using the switch, the following driving modes can be selected:

Position D = proceed with front gear

Position  = the 4 parking indicator lights are activated

Position R = proceed with Reverse

Different driving modes (eSPRO45 - eSPRO45K - eSPROK 2 Seats):

Modality **ECONOMY**

Max speed: 32 Km/h.

The ECO icon appears on the display.

Modality **NORMAL**

Max speed: 37 Km/h.

No icon appears on the display.

Modality **POWER**

Max speed: 45 Km/h.

The PWR icon appears on the display

Version eSPRO45 (1 battery): autonomy 40 Km*

Version eSPRO45 (2 batteries): autonomy 71 Km*

* Normative according 168/2013 EC.

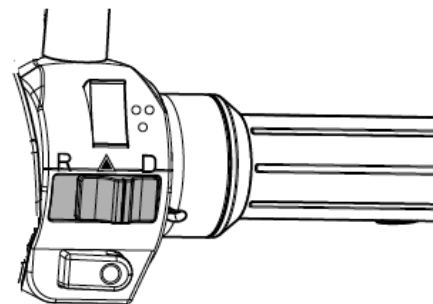

The red **“MODE”** button has a double function, keeping it pressed for 1 sec. The consent is given to the ignition of the vehicle or to the shutdown. Pressing the button quickly changes the assistance modes from ECO to NORMAL to POWER and so on.

WARNING

Over time, lithium-ion batteries undergo a progressive decline in performance which reduces the initial autonomy values.

WARNING

The autonomy data indicated strictly depends on the conditions of use, which can be: slope and / or type of surface of the route, ambient temperature, average speed, level of engine assistance, tire pressure, weight carried and user weight, age of batteries.

Driving mode selection (eS_{PRO}70 - eS_{PRO}70K)

Using the switch it is possible to select three different driving modes:

Modality **ECONOMY**

Modality **NORMAL**

These modes are used to minimize consumption.

Modality **POWER**

Max speed: 67 Km/h

The PWR icon appears on the display

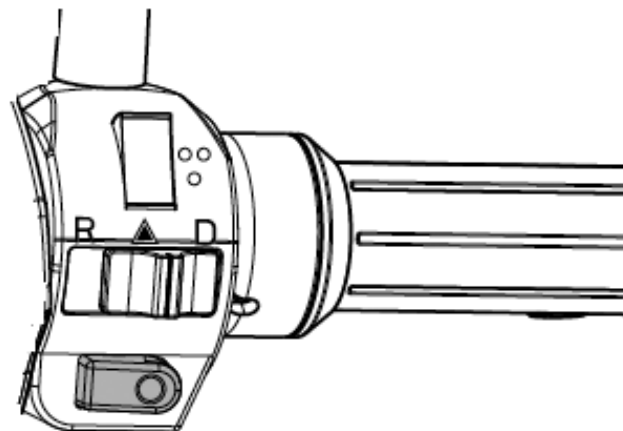

EN

Autonomy 96 Km according to 168/2013 EC.

The autonomy values listed above are valid with the use of 2 connected batteries and with the same charge.

WARNING

Over time, lithium-ion batteries undergo a progressive decline in performance which reduces the initial autonomy values.

WARNING

The autonomy data indicated strictly depends on the conditions of use, which can be: slope and / or type of surface of the route, ambient temperature, average speed, level of engine assistance, tire pressure, weight carried and user weight, age of batteries.

USE

Energy regeneration mode selection

When the scooter is decelerating, the battery can be automatically recharged by activating the energy regeneration mode.

Use the two-position switch to activate or deactivate the energy regeneration mode:

- By pressing the button upwards, the energy regeneration mode is activated, at the same time increasing the deceleration effect.
- By pressing the button down the energy regeneration mode is deactivated.

By combining braking with deceleration, charging will be greater.

When the energy regeneration mode is active the charging lamp is on.

With a high battery charge the regeneration mode is not activated.

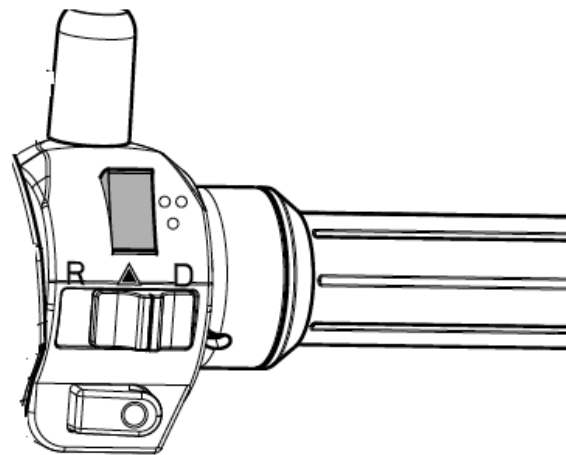

SELECTION OF DISPLAY FUNCTIONS

Odometer data display mode

When turned on, all the display lights will remain on for a few seconds.

Press **SELECT** to change the parameter shown on the display:

Km Total mileage traveled.

The parameter is not editable.

Km/trip Partial mileage traveled.

Press and hold SET to reset while viewing the parameter.

Km/  Kilometers that can be traveled with the remaining battery charge. The value varies according to the conditions of use, the remaining battery charge, the driving mode set and the energy regeneration mode selected.

Vehicle autonomy

The vehicle autonomy value indicated on the display is an estimate of the remaining distance of the vehicle in standard conditions. The estimate becomes less reliable as the indicated Km decreases.

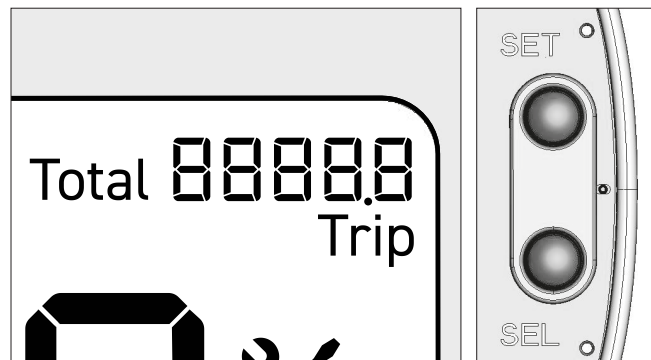
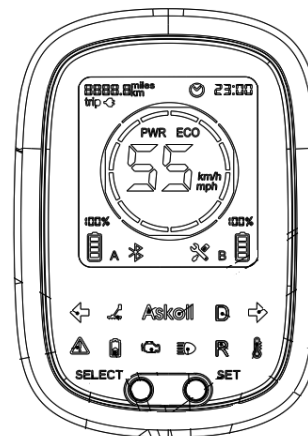

EN

USE

Adjusting the clock function

- Press and hold the **SELECT** button for about 2 seconds: the two digits corresponding to the hour will begin to flash.
- Press **SELECT** repeatedly to set the correct time.
- Press the **SET** button: the minute digits will begin to flash, while the hour digits will return to fixed.
- Press **SELECT** repeatedly to set the correct minutes.
- Press the **SET** button to exit the adjustment.

The time is stored in the vehicle battery so if you have two batteries it is advisable to set the time for the first time with both batteries inserted to synchronize the time. In any case, in the presence of two batteries, the time stored in the battery positioned in compartment **A** is always displayed.

For the description of the battery and its positioning in compartments **A** and **B**, refer to the chapter **"BATTERY AND RECHARGE"**.

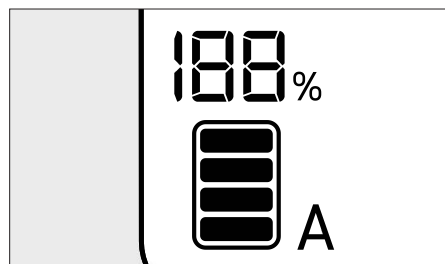
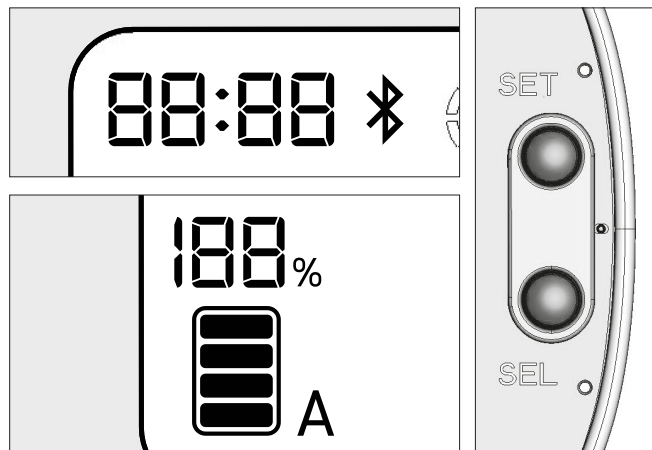
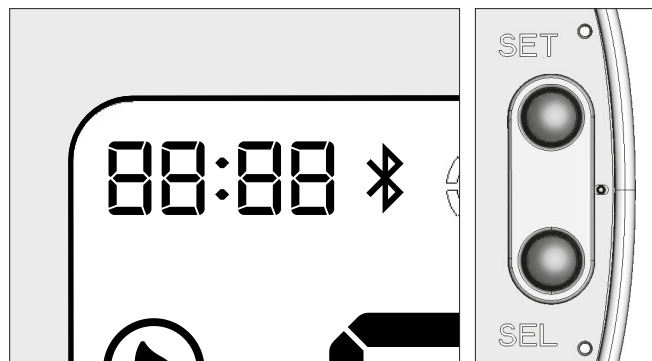

BLUETOOTH®

The eSPRO45, eSPRO45K, eSPRO70, eSPRO70K, eSPROK1 2 Seats scooters are equipped with a Bluetooth module that allows the connection of a mobile device to the vehicle.

Connectivity

The connection status is indicated by the appropriate Bluetooth symbol on the digital display:

- **Flashing symbol:** the module is waiting for connection (only when the vehicle is stationary and for a maximum time of one minute).
- **Symbol on:** the module is connected to a device.
- **Symbol off:** there are no connected devices, the connection timeout has expired or the vehicle is in motion.



EN

When the vehicle is switched on, the Bluetooth module always remains active and ready for connection, even if the symbol on the display is off.

“ASKOLL DRIVE SMART” application

You can download the “ASKOLL DRIVE SMART” application for connection to the BLUETOOTH® system from “Google Play Store” or “Apple Store”, depending on the operating system of your device (Android / iOS)

The BLUETOOTH® word mark and logos are registered trademarks owned by Bluetooth SIG, Inc. and any use of such marks by ASKOLL EVA is under license. Other trademarks and trade names belong to their respective owners.

Hereby, Askoll EVA S.p.A., Via Industria 30, 36031 Dueville (VI) Italy, declares that the HWE213 radio equipment complies with Directive 2014/53 / EU. The full text of the EU declaration of conformity is available at the following internet address: “http://mobility.askoll.com/site/en/assistenza_ricambi/”

USE

OBD DIAGNOSTICS (only eS_{PRO70} e eS_{PRO70} K Euro5)

The eS_{PRO70} e eS_{PRO70}K Euro5 scooter is equipped with the OBD (On Board Diagnostic) error detection system, as per the provisions of the EURO5 Environmental Regulations which came into force on all new vehicles produced from 01 January 2021.

According to the requirements related to ISO 19689: 2016, relating to communication between the vehicle and the external diagnostic equipment, the OBD connection for detecting electronic errors is positioned under the saddle, inside the passenger handle body.

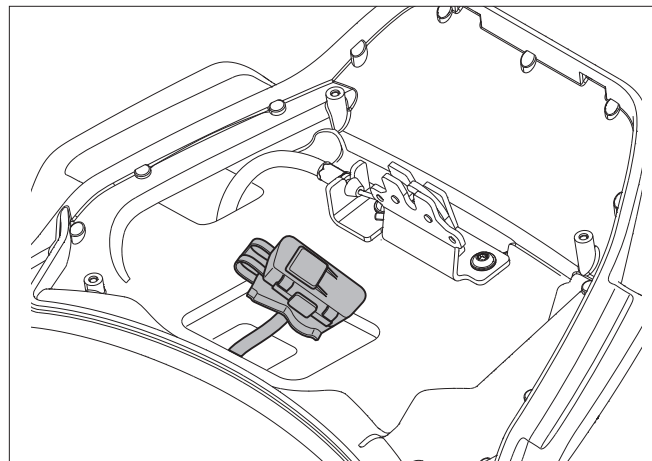

SADDLE

Saddle opening

The lock for opening the saddle is placed under the left side of the saddle.

Insert the key into the lock, turn clockwise and fold the saddle forward.

When closed, the saddle lock will automatically lock.

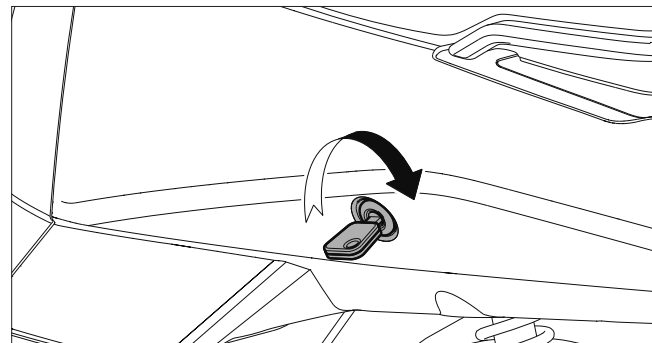

EN

Bag hook

By exerting pressure on the lower part of the hook, the upper part comes out and you can hang an object on it.

When the hook is released, it automatically returns to its seat.

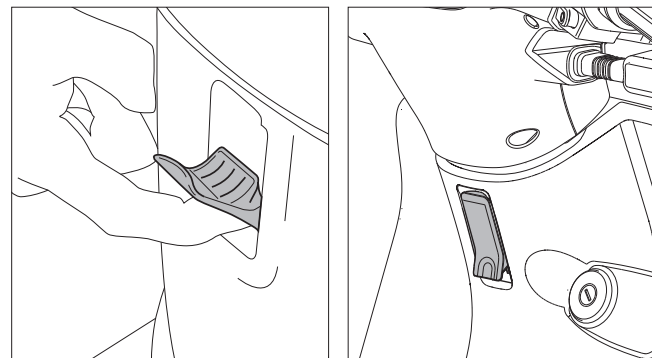
WARNING

The transported object must not prevent or limit the movement of the legs.

WARNING

Avoid placing the entire weight on the hook only, the transported object must still be placed on the platform.

USE

STOP THE SCOOTER

For parking use the stand.

Lower the stand with your foot until it is fully opened and at the same time help yourself by manually lifting the scooter, grabbing it with your right hand on the luggage rack and accompanying it until the scooter is fully supported.

WARNING

By pushing the scooter forward, the stand automatically returns to the starting position: **this operation must always be performed before getting on the scooter.**

WARNING

Avoid sitting on the scooter when it is stationed on the stand.

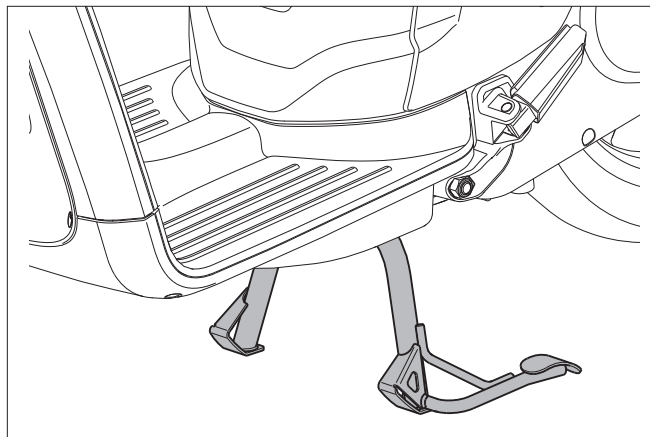

Side stand

Lower the side stand with your foot up when fully opened and accompany the scooter up fully supported on the ground.

WARNING

Before the vehicle restarts make sure the side stand is raised: a safety sensor prevents enabling of the engine when the stand is down.

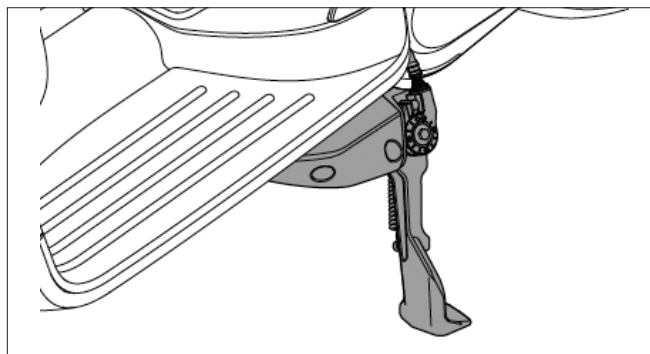

WARNING

Use the tripod on compact and flat surfaces.

WARNING

Pay attention to maneuvers from standstill, especially when positioning the scooter on the stand to prevent the vehicle from falling.

BATTERIES

Original equipment eSPRO45 1.4 vehicles are supplied with a lithium-ion battery. The second battery is supplied as an optional extra (battery model TVC103). The models eSPRO45 2.8 batteries are supplied with two batteries as standard (battery mod. TVC103).

Optional batteries mod. TC107 are available with high capacity (3500 mA) for greater autonomy of the vehicle (standard on eSPRO45 3.4, on eSPRO45K and eSPROK1 2-seater)

The two batteries are housed in the two compartments A and B located under the saddle.

Single battery weight: 7.8 kg (TVC102) - 8.1 kg (TC103).

The batteries must be recharged in an ambient temperature between 0 ° C and +45 ° C.

At low temperatures there may be a reduction in autonomy.

If you use the scooter mod. eS2 the system allows you to use the second optional battery at the same time. The vehicle can still circulate using a single battery that can be placed indifferently in both compartment **A** and compartment **B**. With the use of two batteries, the range doubles.

The battery is an always active component, slight voltage drops may occur even with the display off.

Battery management in the first use of the scooter

With new batteries it is necessary to perform at least 3 - 4 complete charge / discharge cycles bringing the charge to 100% and discharging the batteries to a value closer to 0%, this allows you to correctly align the batteries in the first period of use.

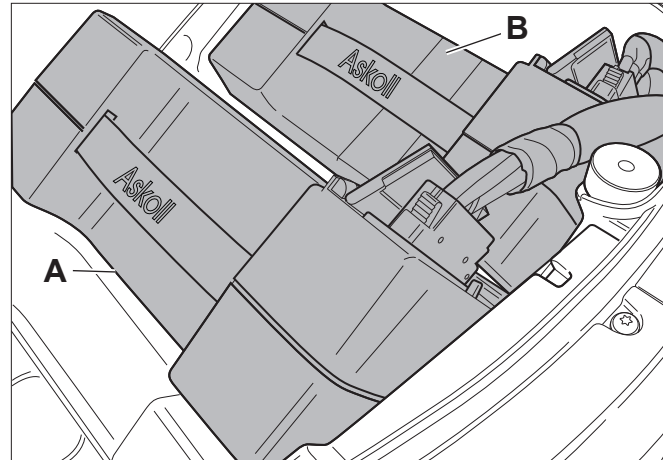

BATTERY AND CHARGING

Percentage of charge

The residual charge expressed as a percentage depends strictly on the conditions of use (slope and / or type of surface of the route, ambient temperature, speed, level of engine assistance, tire pressure, weight carried and user weight, age of the batteries).













The percentage of charge between the 2 batteries may be misaligned but it is not a symptom of malfunction, when the batteries are discharging and fall below the threshold of 20% of residual charge ("reserve" mode) it is advisable to recharge the batteries to 100 %.

Batteries must never remain with less than 20% remaining charge for more than 30 days. In case of non-use of the scooter for long periods, it is recommended never to leave the batteries completely discharged, but to always charge them to at least 50%, and to disconnect the batteries from the scooter..

Check the maintenance of the charge every 2 months.

After leaving the batteries unused for a long time, recharge the batteries to 100%.

BATTERY AND CHARGING

	If the scooter remains with the engine off for a long period in an environment with low temperatures (between 0 ° C and +10 ° C) the charging times may be longer..
	If the scooter is not used for a long time, the batteries must be recharged at least once every two months. In any case, the batteries must never remain with a residual charge of less than 20% for more than 30 days.
	The batteries must not be used with an ambient temperature outside the range between -10 ° C and +45 ° C.
	The batteries should only be recharged using the charger supplied by the manufacturer.
	The batteries must not be subjected to shocks and must not show signs of external damage of any kind.
	The batteries, both in the charging phase and in the storage phase, must not be exposed to sources of heat / cold, humidity, dust or bad weather.
	The warranty covers battery malfunctions resulting from manufacturing defects, inability to recharge and discharge.
	The warranty does not cover the degradation of performance of the batteries due to normal use and aging of the same.
	The manufacturer reserves the right to evaluate the validity of the warranty based on the analysis of the batteries
	Never disconnect the cables from the electrical system with the engine running to avoid damage to the battery.
	Disassembling and / or tampering with the batteries will invalidate the warranty.
	Out of respect for the environment, batteries, at the end of their life cycle, must be discarded, collected and disposed of in accordance with the laws in force.

EN

BATTERY AND CHARGING



Do not use this battery for purposes other than those indicated. Use for purposes other than those intended may give rise to short circuits inside the battery which could ignite.



Danger of fire

- Do not disassemble or break the battery
- As a result of an accident with serious mechanical damage to the battery, short circuits may occur inside the battery itself and the latter could be damaged or catch fire.
- In the event of an accident, leave your vehicle outdoors for an hour, at a safe distance from any flammable materials. With your finger, touch the battery briefly and carefully. If you feel an unusually high heat development, leave your vehicle where it is. Do not continue to use it for any reason. As soon as the battery cools, transport the vehicle to your dealer.
- In the presence of flames or smoke rising from the battery, stop the vehicle immediately. Then extinguish the fire with a fire extinguisher, if available. If you do not have a fire extinguisher available, wait until the fire is extinguished and all parts of the vehicle have cooled down. If there is a risk of the fire spreading to nearby objects, immediately inform the Fire Brigade.

WARNING

Once charging is complete, before removing the batteries, unplug the charger from the power socket.



Failure to comply with the recommendations described above will result in the cancellation of the battery warranty.

Disposal of exhausted batteries

At the end of its useful life, a battery pack containing lithium accumulators must be disposed of according to current regulations and cannot be thrown away as simple waste..

The European Directive for this type of waste establishes that the states adhering to this convention undertake to adopt “appropriate measures” so that the exhausted accumulators are collected separately, for the purpose of their possible recovery or disposal..

In any case, for more up-to-date information on the subject, the user is invited to contact the municipal office in charge of this interest.

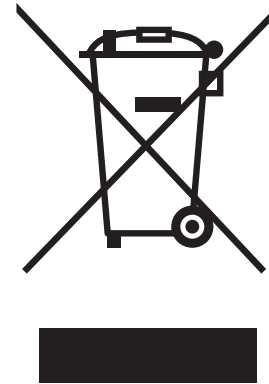

BATTERY AND CHARGING

BATTERY CHARGER

The battery charging operation takes place using the specific charger supplied. The charger supplied with the vehicle is the SMART model, which offers higher performance and shorter charging times.



The supplied charger is designed for mainly indoor use.

BATTERY AND CHARGING

SMART CHARGER

This charger is intended to be used exclusively with Askoll vehicles.

The charger is activated only when connected to the mains with the appropriate power cable.

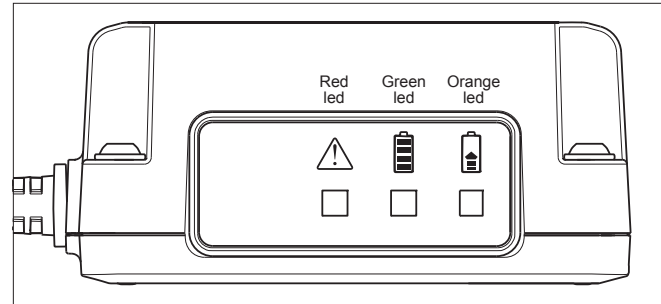

EN

Functions of the charger

- **LEDs off:** charger not connected to the mains.
 - **GREEN LED on:** battery connected and charged.
 - **Flashing orange LED:** battery connected but in the presence of an error, charge not operational. If the problem persists, take the battery to a service center.
 - **ORANGE LED on: charging in progress.**
During the charging phase, the charging progress is indicated by the GREEN LED by means of fast flashes corresponding to this coding:
 - 1 flash of GREEN LED:** battery very low.
 - 2 GREEN LED flashes:** battery on average charged.
 - 3 flashes GREEN LED:** battery close to full charge.
- NOTE:** if there are two batteries connected together via the charge splitter accessory, the indication refers to the more discharged battery of the two.
- **Flashing RED LED:** indicates a high temperature of the battery charger, charging can continue at a reduced or very reduced rate with longer charging times. Place the battery charger in a cool place and never on top of a battery. Make sure that the ventilation grilles are free and that the fans are working correctly, otherwise you need to contact a service center.
 - **RED LED on:** error detected, charging not possible. Try disconnecting and reconnecting from the battery and the mains. If the problem persists, contact a service center.

BATTERY AND CHARGING

Turn on the fans

The charger fans turn on under the following conditions:

- The first 2 seconds after connecting the charger to the power supply
- The charger is being charged.
- The internal temperature of the charger is above 50 ° C.

Charge splitter accessory

The charging splitter accessory, supplied and usable only with the SMART model charger and in “OUT OF BOARD” mode, allows you to recharge two batteries at the same time.

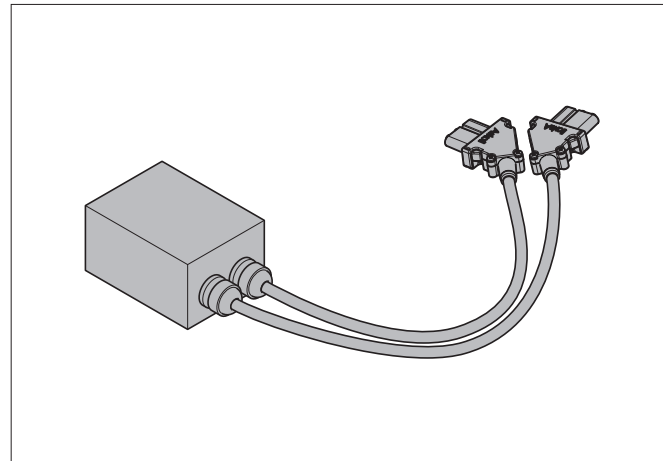

BATTERY AND CHARGING

	<p>The charger is not intended to be used by persons whose physical, sensory or mental capacities are impaired, or with a lack of experience or knowledge, unless they have been able to benefit, through the intermediary of a person responsible for their safety, a surveillance or instructions regarding the use of the charger itself.</p> <p>Tenere il carica batterie e batterie fuori dalla portata dei bambini, sincerarsi che non giochino con i dispositivi.</p>
	<p>Risk of electric shock</p> <ul style="list-style-type: none">• This appliance is equipped with a 3-pole cable with an earthed plug. Make sure that the power socket is also 3-pole with ground contact. If not, contact an electrician to replace the socket.• Do not attempt to defeat the ground pin safety of the 3-prong plug.• Connect the device to a power supply network protected by a differential switch with a sensitivity not exceeding 30 mA.• The electrical connection of the appliance must comply with the data shown on the electrical data label of the same.• Do not use extension cables. If the length of the power cord is insufficient, consult a qualified electrician or installer.• Do not cut and / or repair the power cord• The power cord of this appliance is of a special type: if it is damaged it must be replaced by the manufacturer or its technical assistance service or by a person with similar qualifications, in order to prevent any risk.
	<p>The battery chargers mod. SMART are intended to be used exclusively to recharge batteries mod. TC103 and TC107 in indoor environments. Do not use the chargers for purposes other than those indicated.</p>
	<p>Risk of burns: Always wait until the charger has cooled down before touching or handling it.</p>
	<p>Once charging is complete, wait until the charger has cooled down and then store it in the battery compartment or in a protected indoor environment.</p>

EN

BATTERY AND CHARGING

CHARGING THE BATTERIES

The charge level of the batteries is visible on the left on the digital display of the vehicle. On the display, icon **A** indicates the charge of the battery housed in compartment **A**, icon **B** indicates the charge of the battery housed in compartment **B**. When the charge level is close to 0% it is necessary to recharge.

The battery recharging operation can be performed in two ways:

CHARGING WITH BATTERY ON BOARD

CHARGING WITH OUTBOARD BATTERY



The recharging operation must be performed indoors and protected from bad weather.



To recharge the batteries, first connect the battery charger connector to the battery socket and then connect the battery charger socket to the mains.

BATTERY AND CHARGING

CHARGING WITH BATTERY ON BOARD

To recharge with battery on board, proceed as follows.

Disable the system.

Lift the saddle, remove the charger from its seat and place it above the rear rack: this operation avoids overheating the battery compartment during charging.

Check that the batteries are correctly inserted in the compartments and connected to the connectors, then connect the charging cable.

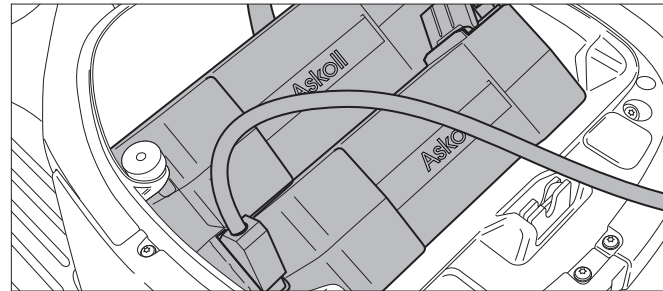
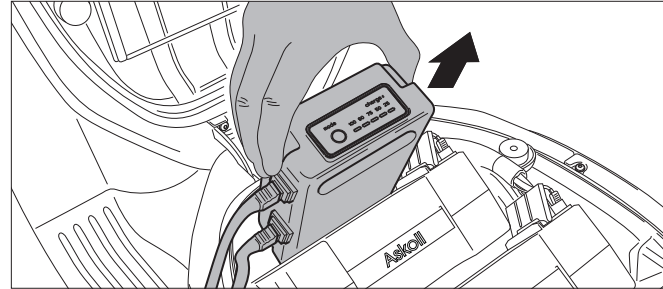

EN

Connect the charger plug to the mains.

When recharging is in progress, the amber warning light will turn on on the instrument panel and will remain on until the plug is removed from the mains.

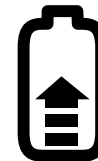
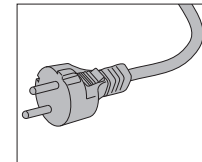

BATTERY AND CHARGING

Locking of the saddle in a raised position for the passage of the cable

During the recharging operations with the battery on board, it is possible to close the saddle using its lock while maintaining a sufficient opening for the passage of the charging cable.

This can be useful in the event that recharging is carried out outdoors, thus maintaining a cover on the batteries that allows the heat generated by the charging process to escape.

Open the saddle, move the spring latch mechanism to the left and hold it down.

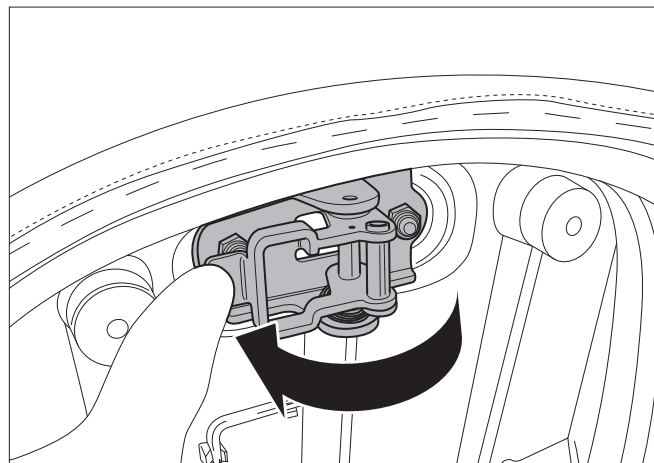
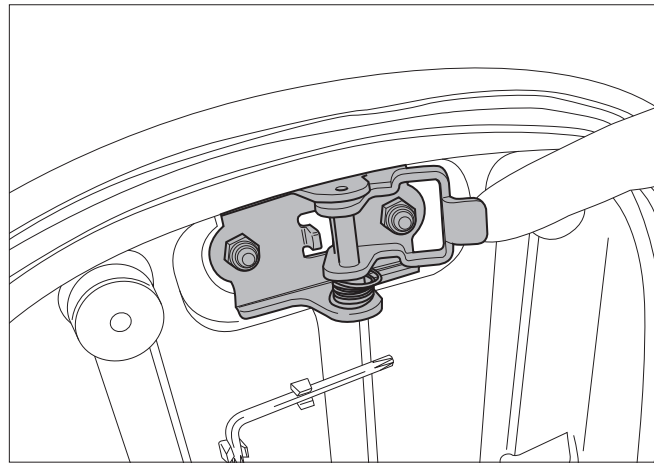

BATTERY AND CHARGING

Close the saddle while keeping the mechanism pressed.

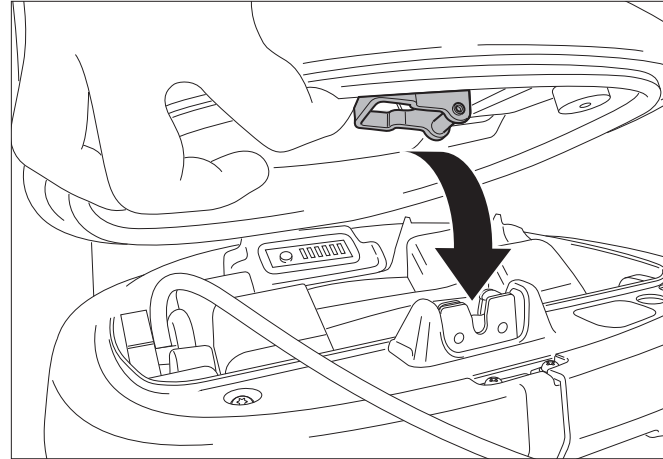

EN

The saddle is locked in a raised position to allow the charging cable to pass through.

By opening the lock with the key and lifting the saddle, the mechanism will automatically return to its original position.

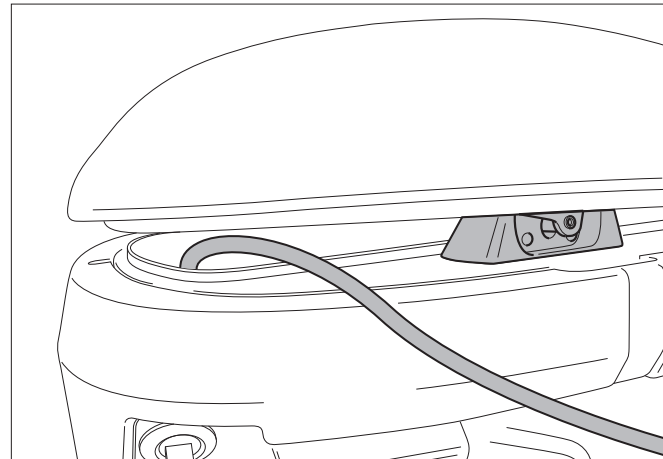

BATTERY AND CHARGING

CHARGING WITH OFF-BOARD CHARGER

The charger can be extracted to allow the recharging of one battery leaving the scooter the possibility to circulate only with the other.

Disconnect the cable from the battery.

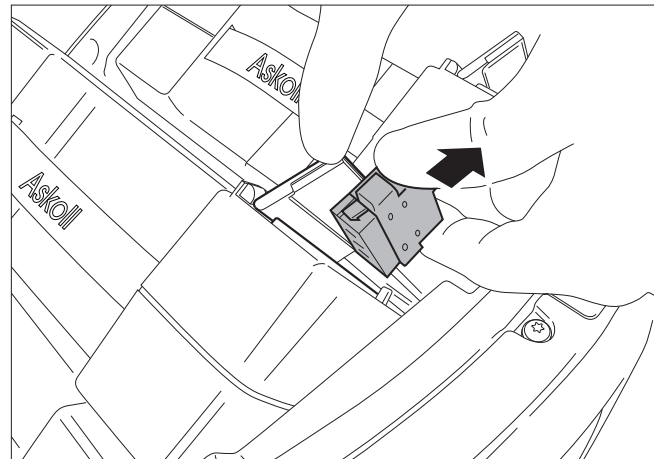

Remove the battery from the housing using the appropriate handle for lifting.

Once extracted, hold it with both hands.

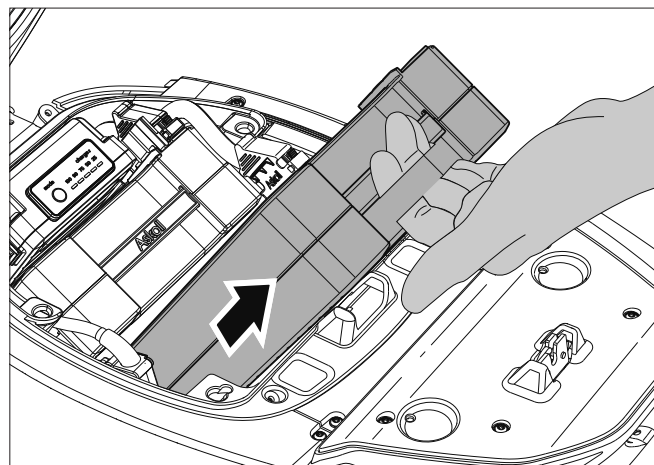

BATTERY AND CHARGING

Disconnect the charger cable connector from its socket.

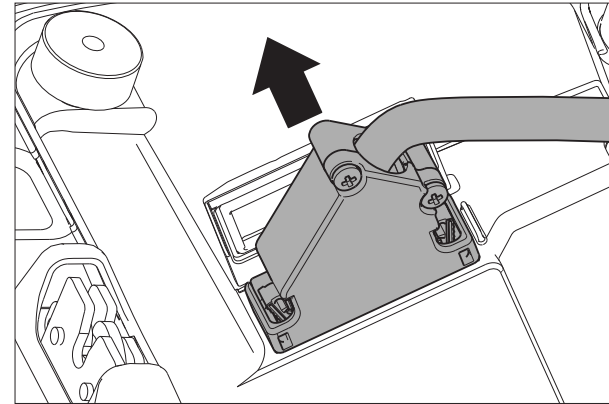

EN

Remove the charger from its housing together with its two cables.

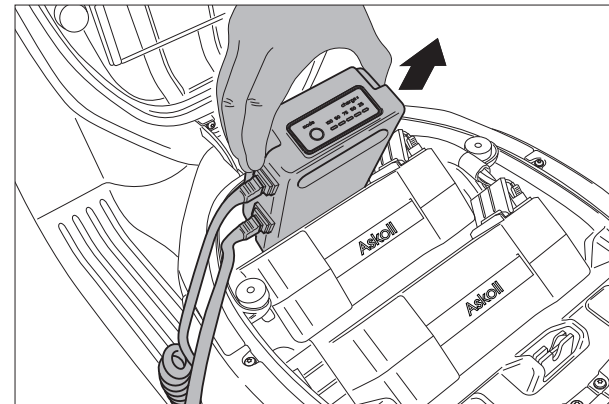

When removing the charger it is recommended to handle it with care to avoid dropping it on yourself or on the ground.

BATTERY AND CHARGING

Place the battery and charger on a stable surface.

First connect the charger cable to the battery socket located under the spring flap, making sure to insert it as far as it will go, then connect the charger to the mains.

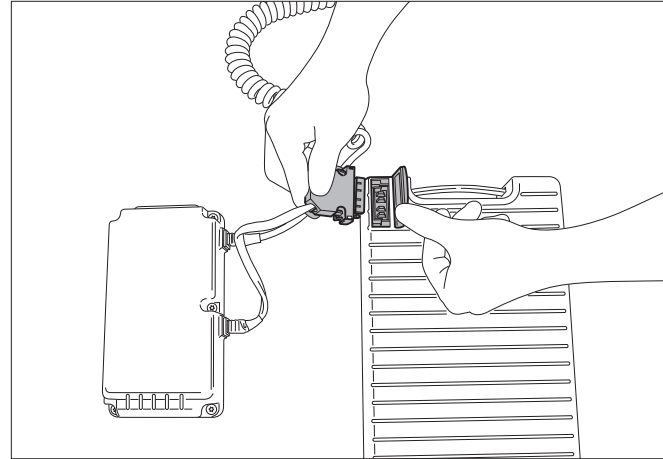

At the end of the recharging operations, replace the charger and the battery in the scooter compartment following these steps:

first replace the charger on the vehicle and connect the cable with connector to the socket on the vehicle.

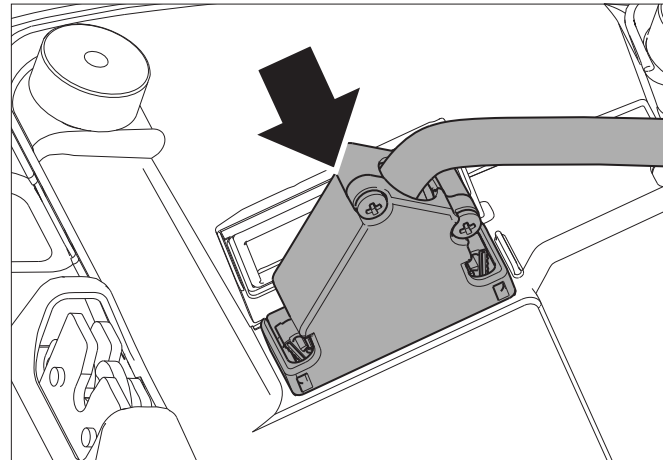

BATTERY AND CHARGING

Reposition the battery in its compartment by holding it by the handle and reconnect the vehicle cable with connector to the socket under the spring-loaded flap on the battery, insert the connector as far as it will go and check that it is well secured.

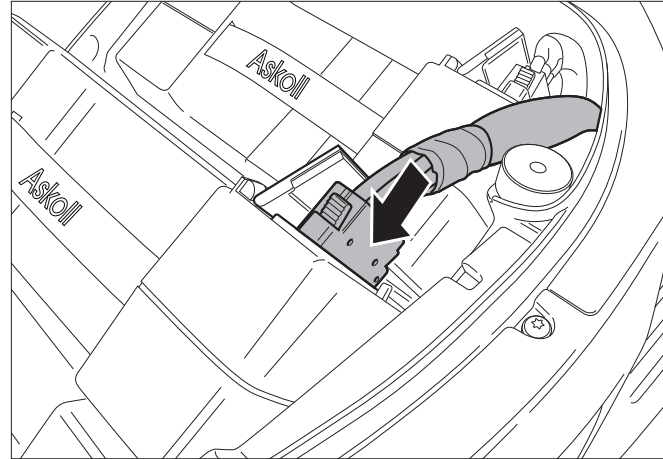

EN

Then place the power cable plug next to the battery charger and rewind the cable over the battery.

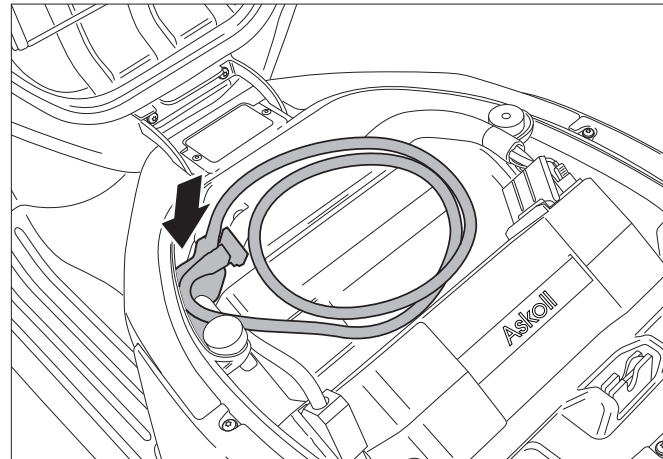

ADJUSTMENTS AND PERIODIC MAINTENANCE

ADJUSTMENTS

REAR MIRRORS

On the left and right sides of the handlebar are mounted the two rear-view mirrors whose adjustment is possible by manually rotating the stem until the mirror is in the desired position.

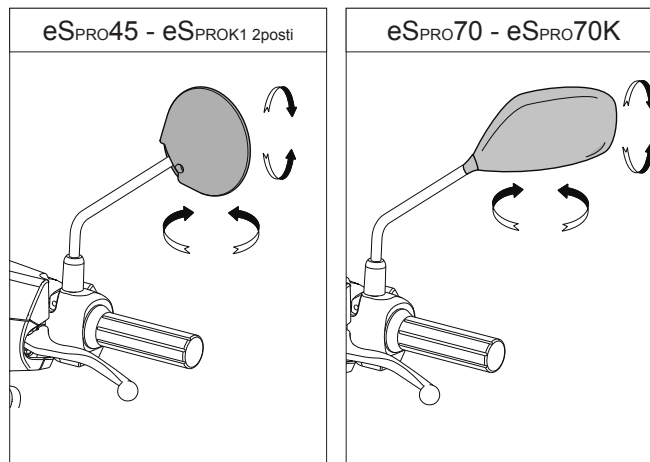

FRONT LAMP

On eSPRO scooters, the front headlight front headlight is equipped with a led-type bulb and does not need to be replaced.

If the bulb runs out, the complete headlight must be replaced.

For replacement, contact an authorised authorised service centre.

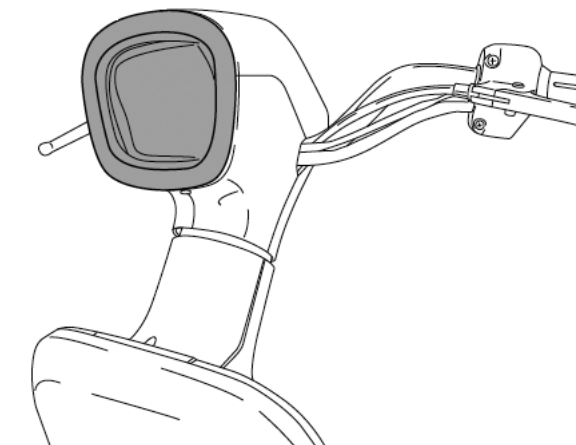

ADJUSTMENTS AND PERIODIC MAINTENANCE

FRONT DISC BRAKE

The wear of the disc and pads is automatically compensated, so it has no effect on the functioning of the brake and does not require adjustments.

If excessive travel is found and the lever gets too close to the knob by activating the brake, it could mean the presence of air in the circuit or the irregular functioning of the brake itself.

Effective braking action must begin after about 1/3 of the brake lever stroke.

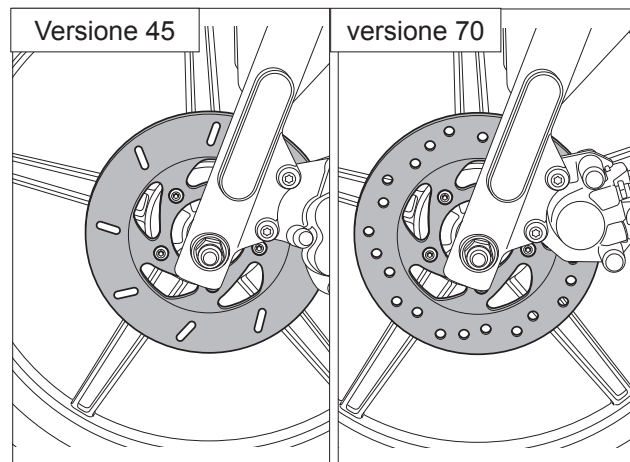

EN

WARNING

If the brake works badly, check the state of wear of the brake pads; if the thickness is very small, they must both be replaced, which must be carried out at an authorized service point..

WARNING

After replacing the pads, operate the brake lever several times to reposition the pads themselves and bring the lever to the right position.

ADJUSTMENTS AND PERIODIC MAINTENANCE

REAR DRUM BRAKE (eSPRO45 - eSPRO45K - eSPROK1 2 Seats)

To adjust the action of the rear brake, turn the nut as shown in the figure.

By tightening the nut, the free play of the control lever and the braking action increases.

Conversely, by unscrewing the nut the free play of the control lever increases and the braking action decreases.

increases and the braking action decreases.

After adjustment, with the brake control lever at rest, check that the wheel turns freely.

The effective braking action should start after approx.

1/3 of the brake lever stroke.

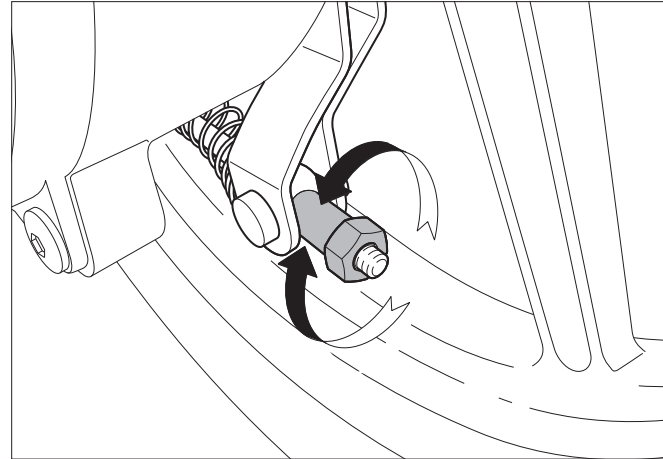

ADJUSTMENTS AND PERIODIC MAINTENANCE

REAR DISC BRAKE (eS_{PRO}70 - eS_{PRO}70K)

The wear of the disc and pads is automatically compensated, so it has no effect on the functioning of the brake and does not require adjustments.

If excessive travel is found and the lever gets too close to the knob when activating the brake, it could mean the presence of air in the circuit or the irregular functioning of the brake itself.

Effective braking action must begin after about 1/3 of the stroke of the brake lever.

REAR DISC BRAKE WITH COMBINED FUNCTION (eS_{PRO}70 - eS_{PRO}70K)

The scooter mod. eS3 uses double braking: by activating the rear brake, the front brake is also activated automatically.

The distribution takes precedence over the rear and the adjustment of the rear adjusting nut affects both wheels.

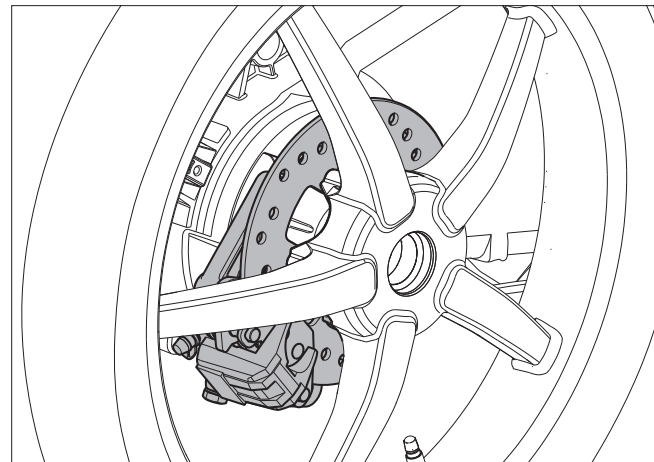

EN

WARNING If the brake works badly, check the state of wear of the brake pads; if the thickness is very small, they must both be replaced, which must be carried out at an authorized service point..

WARNING After replacing the pads, operate the brake lever several times to reposition the pads themselves and bring the lever to the right position.

ADJUSTMENTS AND PERIODIC MAINTENANCE

ORDINARY MAINTENANCE PROCEDURES

TIRES

The vehicle is equipped with tubeless tires.

Check the tire pressure regularly and adjust if necessary before setting off.

**eSPRO45 - eSPRO45K - eSPRO70 - eSPRO70K - eSPROK1
2seats**

Front tire pressure 2 bar.

Rear tire pressure 2,5 bar.

The tires are equipped with a wear indicator and should be replaced as soon as these indicators are visible on the tread.

Also check for any cuts on the sidewalls of the tires or uneven wear. In this case, contact authorized workshops for replacement.

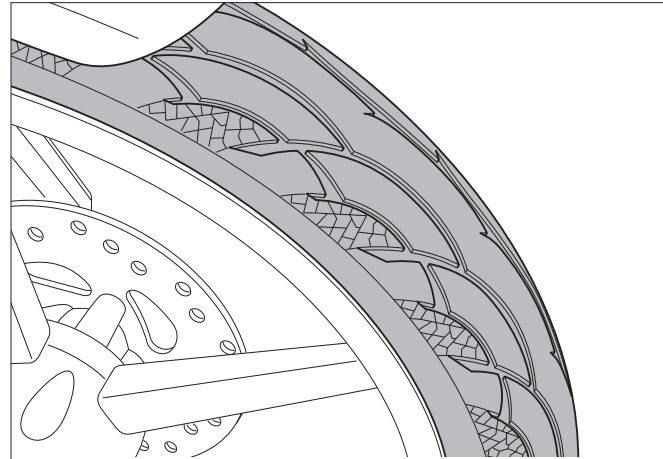

WARNING

Always check the tire pressure when cold, incorrect pressure causes abnormal tire wear and makes driving dangerous.

WARNING

The tire must be replaced when the tread reaches the wear limit set by the regulations in force.

ADJUSTMENTS AND PERIODIC MAINTENANCE

CHECKING THE FRONT BRAKE FLUID LEVEL

The front brake fluid reservoir is equipped with an inspection window to check the fluid level inside the reservoir.

To check the level of the liquid in the tank, it is possible to observe the porthole through the special slot located in the front right part of the handlebar cover.

If the brake fluid level is low or insufficient, **NEVER** top up the reservoir but check the wear of the brake pads and disc and check for any leaks in the brake circuit.

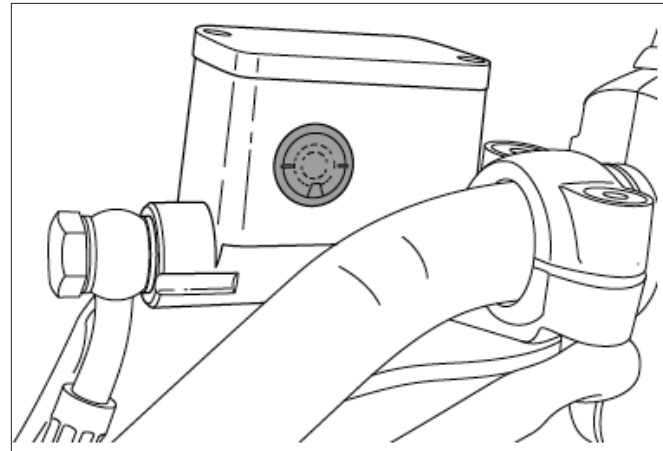

EN

WARNING

The brake circuit fluid is hygroscopic, meaning it absorbs moisture from the surrounding air. If the humidity in the liquid exceeds a certain value, braking will be inefficient.

WARNING

It is advisable to have the fluid changed every 2 years, never use brake fluid contained in containers that are already open or partially used.

WARNING

Verify that only DOT4 rated brake fluid is used.

WARNING

The brake circuit fluid has a high corrosive power. Avoid contact with skin or painted parts. In case of contact with the skin, wash with plenty of water.

ADJUSTMENTS AND PERIODIC MAINTENANCE

CHECKING THE REAR BRAKE FLUID LEVEL (only eSpro 70 - eSpro 70K Euro5)

The rear brake fluid reservoir is equipped with an inspection window to check the fluid level inside the reservoir.

To check the level of the liquid in the tank, it is possible to observe the porthole through the special slot located in the front left part of the handlebar cover.

If the brake fluid level is low or insufficient, **NEVER** top up the reservoir but check the wear of the brake pads and disc and check for any leaks in the brake circuit.

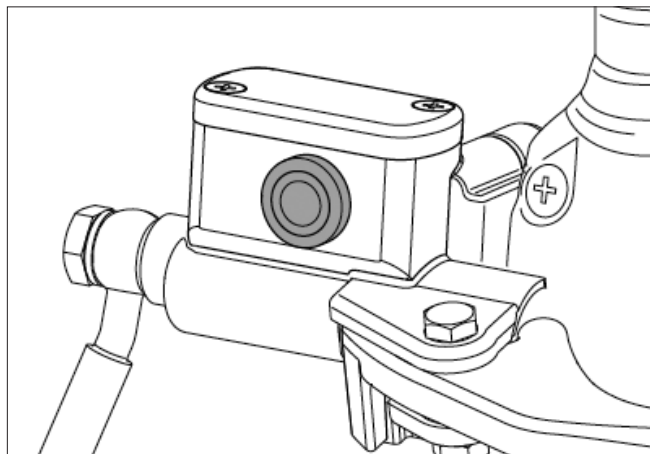

WARNING

The brake circuit fluid is hygroscopic, meaning it absorbs moisture from the surrounding air. If the humidity in the liquid exceeds a certain value, braking will be inefficient.

WARNING

It is advisable to have the fluid changed every 2 years, never use brake fluid contained in containers that are already open or partially used.

WARNING

Verify that only DOT4 rated brake fluid is used.

WARNING

The brake circuit fluid has a high corrosive power. Avoid contact with skin or painted parts. In case of contact with the skin, wash with plenty of water.

ADJUSTMENTS AND PERIODIC MAINTENANCE

HEADLIGHT (eSpro45 - eSpro 70 Euro5)

In the scooter mod. eSpro 70 e eSpro 70K the headlight is equipped with a led bulb and does not need to be replaced.

If the bulb runs out, the complete headlight must be replaced.

For replacement, contact an authorized service point.

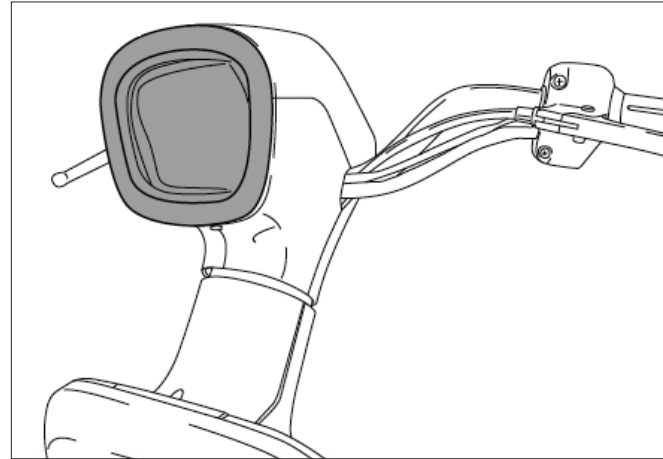

EN

REAR LIGHT UNIT AND DIRECTION INDICATORS (eSpro45 - eSpro 70 Euro5)

The rear light unit, the front and rear direction indicators and the license plate light are equipped with LED lights and are integrated into the vehicle structure.

To replace them, contact an authorized service point.

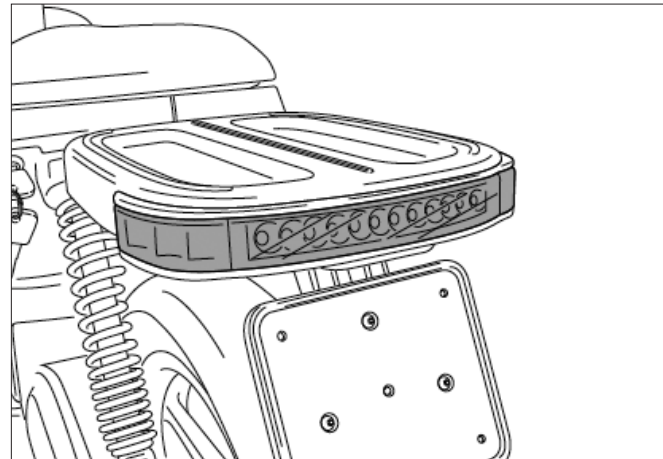

ADJUSTMENTS AND PERIODIC MAINTENANCE

FRONT LIGHT BULB REPLACEMENT (eSpro45 K- eSpro 70 K Euro5 - eSpro K1 2 SEATS)

To replace the H8 35W type bulb of the front headlight proceed as follows:

using the TORX T 20 spanner supplied as an supplied as an accessory and located under the seat, remove the 4 screws that secure the front headlight assembly and separate it from the front headlight basket,

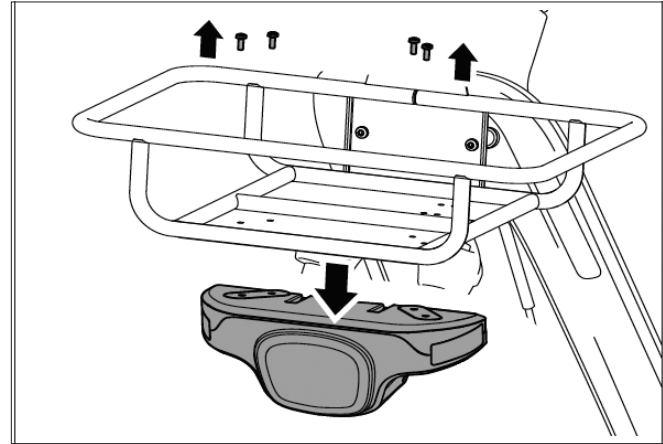

then remove the 2 screws securing the lower cover of the light assembly,

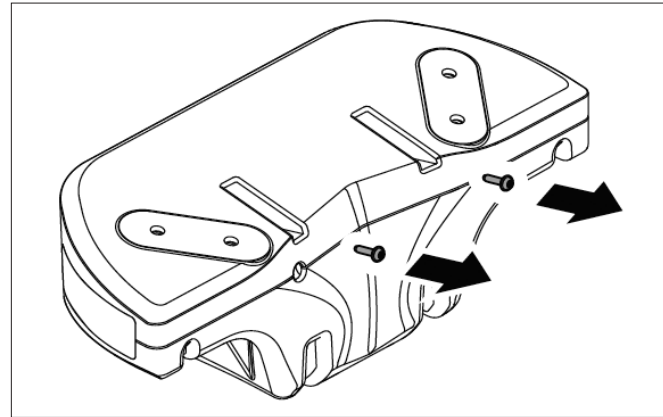

ADJUSTMENTS AND PERIODIC MAINTENANCE

FRONT LIGHT BULB REPLACEMENT (eSpro45 K- eSpro 70 K Euro5 - eSpro K1 2 Seats)

and finally remove the cover to access the LED bulb.
Replace LED bulb with a new one.

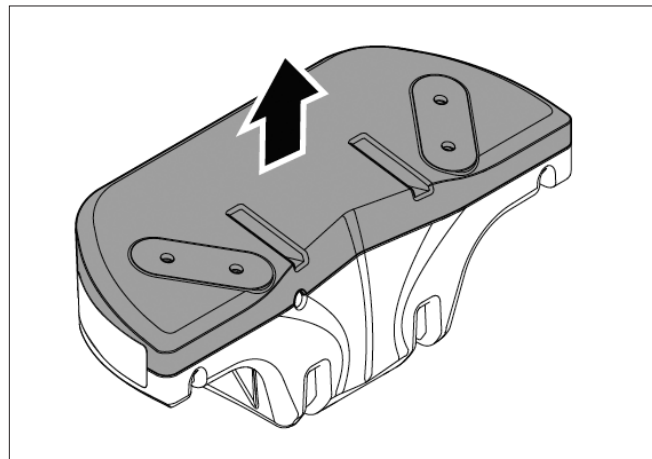

EN

FRONT LIGHT (eSpro45 K- eSpro 70 K Euro5 - eSpro K1 2 SEATS)

On scooter models eSpro45 K - eSpro70 K and eSpro
K1 2 SEATS the front headlight is fitted with a LED
bulb and does not need to be replaced.

led bulb and does not need to be replaced.

In the event of bulb failure, the complete headlight
must be the complete headlight must be replaced.

**For replacement, please contact an authorised an
authorised service centre.**

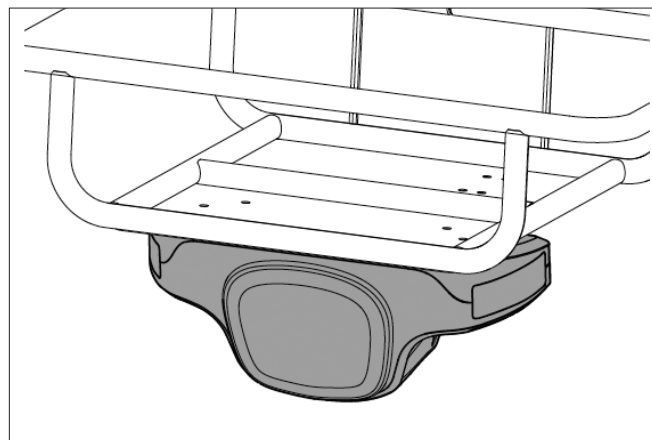

ADJUSTMENTS AND PERIODIC MAINTENANCE

SUMMARY TABLE OF ORDINARY MAINTENANCE PROCEDURES

C: to check; R: regular; L: lubricate; S: substitute

Years	1° Check*	1 year	2 years	3 years	4 years	5 years	6 years	7 years	8 years	9 years	10 years
Km x 1.000	1	3	6	9	12	15	18	21	24	27	30
Front / rear brake fluid (replace every 2 years)		C	S	C	S	C	S	C	S	C	S
Front / rear brake pad wear	C	C/S	C/S	C/S	C/S	C/S	C/S	C/S	C/S	C/S	C/S
Front / rear brake disc check	C	C/S	C/S	C/S	C/S	C/S	C/S	C/S	C/S	C/S	C/S
Wear of rear brake shoes		C/R	C/R/S	C/R/S	C/R/S	C/R/S	C/R/S	C/R/S	C/R/S	C/R/S	C/R/S
Transmission belt	C	C	S	C	S	C	S	C	S	C	S
Pulley check	C	C	S	C	S	C	S	C	S	C	S
Nuts bolts fasteners	C	C	C	C	C	C	C	C	C	C	C
Kick stands	C/L	C/L	C/L	C/L	C/L	C/L	C/L	C/L	C/L	C/L	C/L
Steering bearings	C		C		C		C		C		C
Front / rear tire.	C	C/S	C/S	C/S	C/S	C/S	C/S	C/S	S	C/S	C/S
Front fork / rear shock absorber	C	C	C	C	C	C	C	C	C	C	C
Control of electrical devices and operation of the electrical system	C	C	C	C	C	C	C	C	C	C	C

NOTE: (*) at 1000 Km **ALWAYS** carry out the first vehicle check.

Coupon validity: the coupons must be carried out within the kilometers validity indicated. If the distance indicated is not reached, it is advisable to carry out a check on the vehicle every year.

ADJUSTMENTS AND PERIODIC MAINTENANCE

PULIZIA DEL VEICOLO

CLEANING THE VEHICLE





To avoid the onset of oxidation, wash the scooter every time it is used in particular atmospheric or road conditions, such as roads sprinkled with salt or de-icing products in winter, atmospheric pollution conditions such as cities, industrial areas, areas with high salinity or humidity, in the atmosphere such as maritime areas.

Prevent dirt deposits, industrial dust residues, dead insects, bird droppings, etc. on the bodywork for a long time...

Use a low pressure water jet to soften the dirt deposited on the painted surfaces, then remove them with a soft body sponge soaked in plenty of water and shampoo and then rinse and dry with suede.

Avoid washing the scooter directly in the sun, especially in summer, to prevent the bodywork from warming up and immediately drying the shampoo before rinsing and this can damage the paint.

EN

	Do not use high-pressure water jets for washing, in order to avoid damaging delicate vehicle components.
	During washing, never direct the water jet directly on delicate components such as electrical wiring and their connections.
	Never use rags soaked in petrol, alcohol or potentially corrosive liquids for washing painted surfaces, plastics or for the saddle upholstery to avoid loss of gloss and mechanical characteristics of the materials, or their damage..
	Scooter washing must be carried out in areas equipped for the collection and purification of the liquids used.

ADJUSTMENTS AND PERIODIC MAINTENANCE

INACTIVITY OF THE VEHICLE

In preparation for a long period of inactivity it is advisable:

- carry out a general cleaning of the scooter,
- carry out storage in a covered place,
- park the scooter on the stand to prevent the wheels from remaining in contact with the ground in the same position,
- cover the scooter with a tarp.

ERROR CODES

Communication system failure: Communication problems are detected between the vehicle's intelligent units. It is advisable to take the vehicle to an authorized workshop.

Inverter failure: the system detects a failure in the inverter unit. It is advisable to take the scooter to an authorized workshop.

ECU failure: the system detects a failure on the ECU unit. It is advisable to take the scooter to an authorized workshop.

Power circuit failure: the system detects abnormal motor absorption. For safety reasons, the system does not deliver power. It is advisable to take the vehicle to an authorized workshop.

Battery A fault: the system detects a fault in battery pack A. It is recommended to take the battery to an authorized workshop.

eSPRO45 - eSPRO45K - eSPRO70 - eSPRO70 - eSPROK1 2POSTI

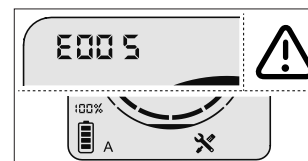
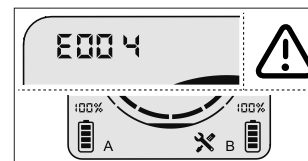
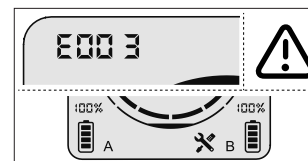
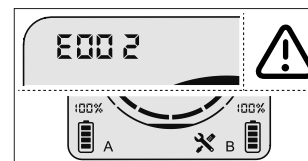
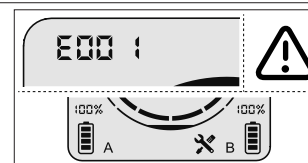

ERROR CODES

eSPRO45 - eSPRO45K - eSPRO70 - eSPRO70 - eSPROK1 2POSTI

Battery B fault: the system detects a fault in the battery pack B. It is advisable to take the battery to an authorized workshop.

Battery overtemperature: the system detects an excessive battery temperature which inhibits the delivery of power to the vehicle. It is necessary to remove the vehicle from high temperature environments and wait for the batteries to cool.

Inverter overtemperature: the system detects an excessive temperature of the electronic unit. Power delivery to the vehicle is inhibited until the temperature drops. It is advisable to move the vehicle away from heat sources.

Motor overtemperature: the system detects an excessive motor temperature. Reduced power operation is allowed to allow cooling.

Front projector malfunction: the system detects the break or malfunction of the front lamp. Check its operation and replace it at an authorized workshop.

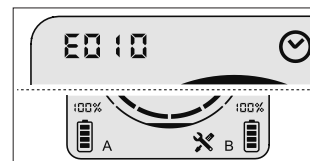
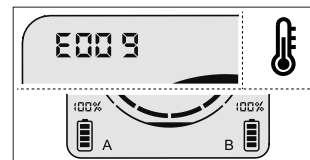
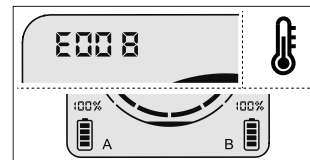
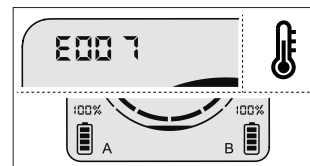
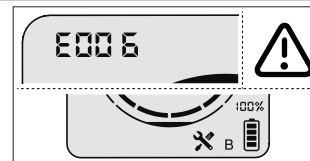

eSPRO45 - eSPRO45K - eSPRO70 - eSPRO70K - eSPROK1 2POSTI

Direction indicators malfunction: the system detects the breakage or malfunction of the direction indicators. Check their operation and replace them at an authorized workshop.

Taillight and license plate light malfunction: the system detects breakage or malfunction of the taillight and license plate light. Check their operation and replace them at an authorized workshop.

Fault in the front position headlight circuit (eS3 EVO only): the system detects a short circuit on the front position light.

Side stand sensor fault: detection of abnormal signal control system on stand.

Phase 1 check integrity of the High-Low level signal of the two inputs - Pin 1-2-4 on CONN INVERTER signal.

To verify the functionality, it is required to measure the inversion of the 2 signals in the indicated pins and, if not, replace the sensor.

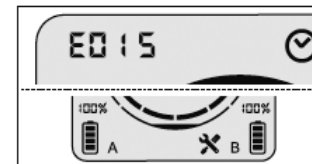
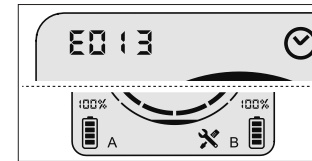
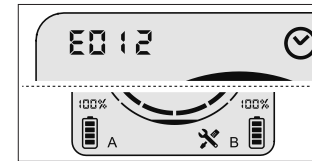
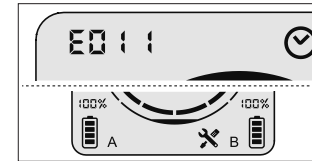

EN

TECHNICAL DATA

DIMENSIONS OF THE SCOOTER

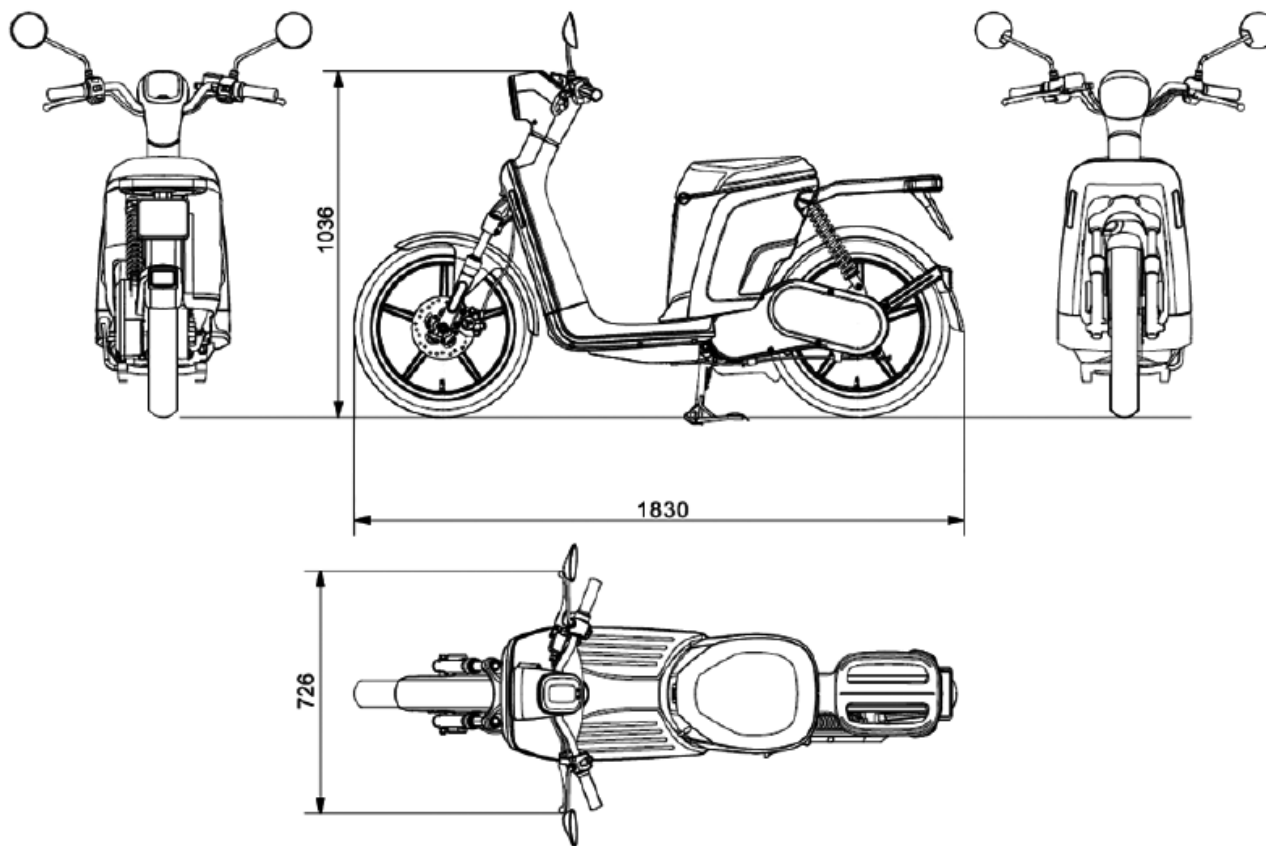

DIMENSIONS OF THE SCOOTER eSpro45 K - eSpro70 K

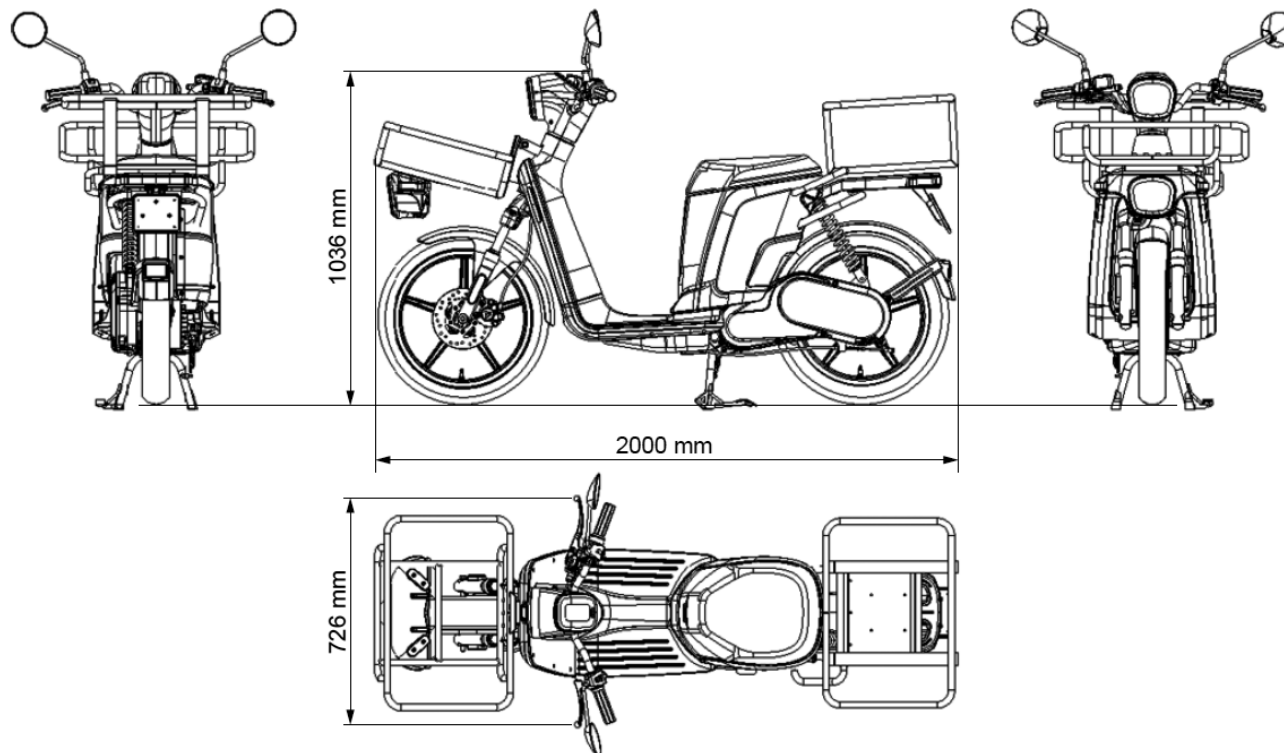

EN

TECHNICAL DATA

DIMENSIONS OF THE SCOOTER eSpro K1 2 Seats

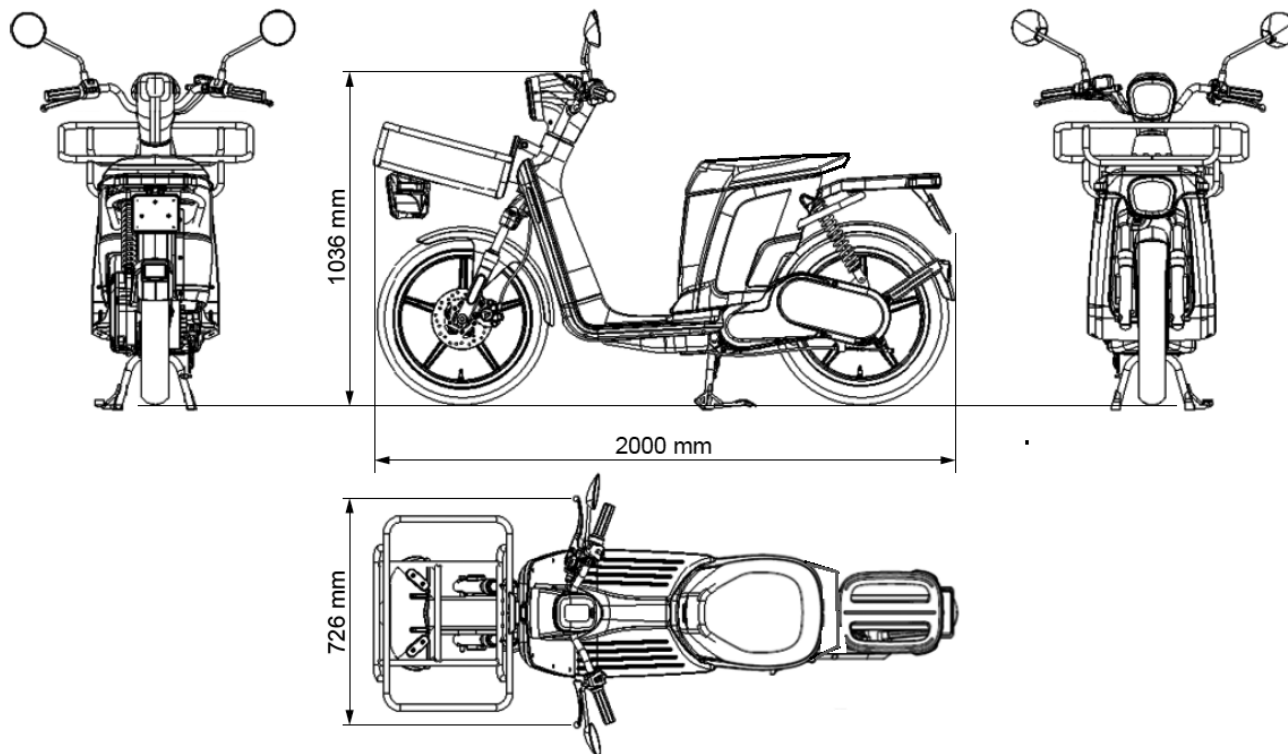

TECHNICAL DATA

MODEL	eSPRO 45 (1.4) - eSPRO 45 (2.8)	eSPRO 45 (3.4)- eSPRO 45K (3.4) eSPRO 70 (2.8)- eSPRO 70K (2.8) - eSPRO K1 2 seats (3.4)
DATI MOTORE		
Model	Brushless permanent magnet sinusoidal motor	
Motor Type	EME 200	EME 201
Operating voltage	54V	
MAX Power	2,2 kW electronically limited	2,7 kW electronically limited * with 2 batteries connected and with the same charge according 168/2013 EC

EN

BATTERY		
Model	TVC 103	TVC 103 (veicoli 2.8) TVC107 (veicoli 3.4)
Charge	LI - ION	
Weight	7,8 Kg	8,1 Kg
Autonomy	40 Km (vehicle 1.4)	96 Km * with 2 batteries connected and with the same charge according 168/2013 EC
	96 Km * with 2 batteries connected and with the same charge according 168/2013 EC	
Operating Temperature	In exercise -20 °C a +45 °C	

TECHNICAL DATA

MODEL	eSPRO 45 (1.4) - eSPRO 45 (2.8)	eSPRO 45 (3.4)- eSPRO 45K (3.4) eSPRO 70 (2.8)- eSPRO 70K (2.8) - eSPRO K1 2 seats (3.4)
VEHICLE DATA		
Length	1830 mm - 2000 mm (model K e K1 2Seats)	
Large	726 mm	
Wheelbase	1245 mm	
Height of mirror attachments	1036 mm	
Front tire pressure	2 bar	
Rear tire pressure	2,5 bar (model PRO45 1.4-2.8) - 2,8 bar (PRO45 3.4 - 45K - 70K - K1 2Seats)	
Curb weight	72 Kg (model PRO45 1.4-2.8) - 77 Kg (PRO45 3.4 - 45K - 70K - K1 2Seats)	
Maximum permissible weight	245 Kg (vehicle + driver + additional load)	
Maximum permissible weight of the rear rack	40 Kg centered on the roof rack	
Places	1 seat (PRO45 - PRO45K - PRO70 - PRO70K) 2 seats (PRO K1 2 Seats)	
Trasmission	Mixed poly-v / toothed belt	
FRONT LIGHT UNIT DATA		
Headlight	LED	
Direction indicators	LED	
Dashboard lights	LED	
REAR LIGHT UNIT DATA		
Taillight	LED	
Stop light	LED	
Direction indicators	LED	
License plate light	LED	

Askoll

Askoll EVA SpA
Electric Vehicle Askoll

EU declaration of conformity

This declaration of conformity is issued under the sole responsibility of the manufacturer

Producer: Askoll EVA S.p.A.
Address: Via industria 30, 36031 Dueville (VI), Italia

Object of the declaration

Description: Caricabatterie per pacco batteria e-Scooter
Type: TVC20x; TC20x
Models: TVC202; TC203; TC204; TC205; TC206

The object of the declaration described above complies with the following Union harmonization legislation on the subject:

Directive 2014/35/EU (LVD);
Directive 2014/30/EU (EMC);
Directive 2011/65/EU; Delegate Directive (EU) 2015/863

The following harmonized standards have been applied:

EN 60335-1:2012+AC:2014+A11:2014+A13:2017+A1:2019+A14:2019+A2:2019+A15:2021;
EN 60335-2-29:2004 + A2:2010 + A11:2018;
EN 62233:2008;
EN 55014-1:2017+A11:2020; EN 55014-2:1997+A1:2001+A2:2008+AC:1997
EN 61000-3-2:2014; EN 61000-3-3:2013;
EN IEC 63000:2018

EN

Place

Dueville

Date

19/10/2021

Name, role, signature

Gian Franco Nanni (CEO)



